



RGV-RAV-090-180

Product Specifications

SINGLE PACKAGE ROOFTOP UNITS WITH X-VANE™ FAN TECHNOLOGY: GAS HEATING/ELECTRIC COOLING (RGV) AND ELECTRIC COOLING/OPTIONAL ELECTRIC HEAT (RAV) 7.5 TO 15 TON

The new 7.5 to 15 Ton RGV/RAV090-180 series rooftop units (RTU) with X-Vane Fan Technology provides value added benefits never seen in this type of equipment before. New major design features include:

- Patented, industry's first efficient indoor fan system using Vane Axial fan with electric commutated variable speed motor. As compared to today's typically used belt drive with forward curve fans, system provides reliable operation with:
 - 75% fewer moving parts
 - No fan belts, pulleys, shaft, and shaft bearings
 - 40% more efficient than traditional belt drive forward curve fans
 - Slow ramp up capability for better sound and comfort control
 - Internal protection from phase reversal and phase loss situations
 - High external static capability
 - Slide out blower assembly design
- Reliable and highly safety protected 2 stage cooling with tandem scroll compressors technology, fully active evaporator coil, and mixed air temperature protection on all models
- New unit control board with intuitive indoor fan that uses simple dial and switch adjustments
- Reliable copper tube/aluminum fin condenser coil with 5/16 in. tubing to help reduce refrigerant charge and reduce weight versus prior designs

RGV/RAV units up to 15 tons are specifically designed to fit on our existing roof curbs that were installed back to 1989, which makes replacement easy and eliminates the need for curb adapters, changing utility connections or supporting curb overhang situations.

2 speed indoor fan motor system helps deliver IEERs up to 15.2. All models are capable of either vertical or horizontal air-flow without dedicated models or field install kits. The 15 ton models require a field-installed supply air kit.

With "no-strip" screw collars, handled access panels, and more, the unit is easy to install, easy to maintain, and easy to use. Your new 7.5 to 15 ton RGV/RAV rooftop unit (RTU) provides optimum comfort and control from a packaged rooftop.

Installation ease

All RGV/RAV090-180 units are field-convertible to horizontal airflow, which makes it easy to adjust to unexpected job-site complications. Lighter units make for easy replacement and aid in the structural approval process. Units have simple, fast plug-in connections to the standard integrated unit control board (UCB). Clearly labeled connections points to reduce installation time. Also, a large control box provides room to work.

Easy to maintain

With the new X-Vane Fan Vane Axial fan and direct drive ECM motor, there is no longer a need to adjust or replace belts or pulleys as in past designs. This frees up maintenance, installation, and commissioning time.

Easy access handles provide quick and easy access to all normally serviced components. Our "no-strip" screw system has superior holding power and guides screws into position while preventing the screw from stripping the unit's metal.

Sloped, corrosion resistant composite drain pan sheds water and won't rust.

Easy to use

The newly re-designed Unit Control Board puts all connections and troubleshooting points in one convenient place. Most low voltage connections are made to the same board and make it easy to access it. Setting up the fan is simple by an intuitive switch and rotary dial arrangement. RGV/RAV090-180 rooftops have high and low pressure switches, a new mixed air temperature switch, a filter drier, and 2 in. filters standard.



RGV/RAV090-180

X-Vane Fan™

Table of contents

	Page
Features/Benefits	2
Model Number Nomenclature	3
Capacity Ratings	5
Physical Data	8
Options and Accessories	12
Base Unit Dimensions	17
Accessory Dimensions	35
Performance Data	37
Fan Data	59
Electrical Data	100
Typical Wiring Diagrams	124
Sequence of Operation	138
Application Data	140
Guide Specifications	142

X-Vane Fan Technology

Direct drive X-Vane Fan Technology indoor fan system uses vane axial fan design and electrically commutated motors. This new Vane Axial design over past belt drive systems has 75% fewer moving parts, uses up to 40% less energy and has no fan belts, blower bearings, or shaft.

Design features include:

- Two-stage units deliver IEERs up to 15.2.
- All models are capable of either vertical or horizontal airflow.
- RGV/RAV090-180 rooftop units (RTU) were designed by customers for customers. With “no-strip” screw collars, handled access panels, and more the unit is easy to install, easy to maintain, and easy to use. Your new 7.5 to 15 ton RGV/RAV090-180 rooftop unit (RTU) provides optimum comfort and control from a packaged rooftop.

Features/Benefits

Value-added features include:

- Optional Hot Gas Re-Heat dehumidification system for improved part load humidity performance
- Single point gas and electrical connections
- 7.5 to 15 ton models use fixed TXV refrigerant metering device
- Scroll compressors with internal line-break overload protection
- Units come with an easy access tool-less filter door. Filter track tilts out for filter removal and replacement. All filters are the same size in each unit

Operating efficiency and flexibility

These RGV/RAV packaged rooftops meet the Department of Energy (DOE) 2023 efficiency standard, as well as the latest ASHRAE (American Society of Heating, Refrigerating, and Air-Conditioning Engineers) 90.1 and IECC¹ (International Energy Conservation Code) minimum IEER efficiency requirements.

Field convertible airflow

All RGV/RAV090-180 units are field-convertible to horizontal airflow, which makes it easy to adjust to unexpected job site complications. 15 ton models require a simple supply duct cover kit to field convert from factory vertical to horizontal.

Comfort control

Our patented Hot Gas Re-Heat dehumidification system is an all-inclusive factory-installed option on gas heating/electric cooling and electric cooling/electric heat models. This system provides reliable, flexible operation to meet indoor part load sensible and latent requirements as well as multiple gas heat and electric heat sized to fit an array of applications.

1. IECC is a registered trademark of International Code Council, Inc.

Model number nomenclature

RGV090-180 MODEL NUMBER NOMENCLATURE

MODEL SERIES	R	G	V	0	9	0	L	D	2	A	0	A	A	B
Position Number	1	2	3	4	5	6	7	8	9	10	11	12	13	14
R = Rooftop														
G = Gas Heat / Electric Cooling	Type													
V = R-410A with X-Vane™ Fan	Standard Efficiency													
090 = 90,000 BTUH = 7.5 Tons														
102 = 102,000 BTUH = 8.5 Tons														
120 = 120,000 BTUH = 10 Tons														
150 = 150,000 BTUH = 12.5 Tons														
180 = 180,000 BTUH = 15 Tons	Nominal Cooling Capacity													
H = 208/230-3-60														
L = 460-3-60														
S = 575-3-60	Voltage													
D = Low Heat														
E = Medium Heat														
F = High Heat														
S = Low Heat, Stainless Steel Heat Exchanger														
R = Medium Heat, Stainless Steel Heat Exchanger														
T = High Heat, Stainless Steel Heat Exchanger	Heating Capacity													
2 = Standard/Medium Static Direct Drive ECM with X-Vane™ Fan														
3 = High Static Direct Drive ECM with X-Vane Fan														
4 = High Static Direct Drive ECM with X-Vane Fan and Hot Gas Re-Heat														
5 = Standard/Medium Static, Vertical Supply and Filter Status Switch														
6 = High Static, Vertical Supply and Filter Status Switch														
7 = High Static, Vertical Supply and Filter Status Switch with Hot Gas Re-Heat	Motor (Indoor Fan)													
A = None														
B = Low Leak EconoMi\$er® X with Barometric Relief, OA Temp Sensor														
E = Low Leak EconoMi\$er X with Barometric Relief, + CO ₂ Densor, OA Temp Sensor														
H = Low Leak EconoMi\$er X with Barometric Relief, Enthalpy Sensor														
L = Economizer with Barometric Relief + CO ₂ Sensor, Enthalpy Sensor														
U = Ultra Low Leak Economizer with Barometric relief, OA Temp Sensor														
W = Ultra Low Leak Economizer with Barometric relief, Enthalpy Sensor	Outdoor Air Options / Control													
OA = Standard														
4B = Non Fused Disconnect Switch														
AA = Hinged Access Panels														
AT = Un-Powered Convenience Outlet														
BB = Powered Convenience Outlet														
BP = Return Air Smoke Detector														
BR = Supply Air Smoke Detector														
CJ = Condensate Overflow Switch	Factory Installed Options													
A = Aluminum/Copper Condenser and Evaporator Coil														
B = Precoat Aluminum/Copper Condenser with Aluminum/Copper Evaporator														
C = E-Coated Aluminum/Copper Condenser with Aluminum/Copper Evaporator														
D = E-Coated Aluminum/Copper Condenser and Evaporator														
E = Copper/Copper Condenser and Aluminum/Copper Evaporator														
F = Copper/Copper Condenser and Evaporator	Condenser / Evaporator Coil Configuration													
A = Economizer control for EconoMi\$er IV and all others (except factory-installed EconoMi\$er X)														
B = Economizer control for factory-installed for EconoMi\$er X	Economizer Control													

Model number nomenclature (cont)

RAV090-180 MODEL NUMBER NOMENCLATURE

MODEL SERIES	R	A	V	0	9	0	L	0	2	A	0	A	A	B
Position Number	1	2	3	4	5	6	7	8	9	10	11	12	13	14
R = Rooftop														
A = Cooling Unit with Electric Heat	Type													
V = R-410A with X-Vane™ Fan	Standard Efficiency													
090 = 90,000 BTUH = 7.5 Tons 102 = 102,000 BTUH = 8.5 Tons 120 = 120,000 BTUH = 10 Tons 150 = 150,000 BTUH = 12.5 Tons 180 = 180,000 BTUH = 15 Tons	Nominal Cooling Capacity													
H = 208/230-3-60 L = 460-3-60 S = 575-3-60	Voltage													
0 = No Heat (Field Installed Only)	Electric Heating Capacity													
2 = Standard/Medium Static Direct Drive ECM with X-Vane™ Fan 3 = High Static Direct Drive ECM with X-Vane Fan 4 = High Static Direct Drive ECM with X-Vane Fan and Hot Gas Re-Heat 5 = Standard/Medium Static, Vertical Supply and Filter Status Switch 6 = High Static, Vertical Supply and Filter Status Switch 7 = High Static, Vertical Supply and Filter Status Switch with Hot Gas Re-Heat	Motor (Indoor Fan)													
A = None B = Low Leak EconoMi\$er® X with Barometric Relief, OA Temp Sensor E = Low Leak EconoMi\$er X with Barometric Relief, + CO ₂ Densor, OA Temp Sensor H = Low Leak EconoMi\$er X with Barometric Relief, Enthalpy Sensor L = Economizer with Barometric Relief + CO ₂ Sensor, Enthalpy Sensor U = Ultra Low Leak Economizer with Barometric Relief, OA Temp Sensor W = Ultra Low Leak Economizer with Barometric Relief, Enthalpy Sensor	Outdoor Air Options / Control													
0A = Standard 4B = Non Fused Disconnect Switch AA = Hinged Access Panels AT = Un-Powered Convenience Outlet BB = Powered Convenience Outlet BP = Return Air Smoke Detector BR = Supply Air Smoke Detector CJ = Condensate Overflow Switch	Factory Installed Options													
A = Aluminum/Copper Condenser and Evaporator Coil B = Precoat Aluminum/Copper Condenser with Aluminum/Copper Evaporator C = E-Coated Aluminum/Copper Condenser with Aluminum/Copper Evaporator D = E-Coated Aluminum/Copper Condenser and Evaporator E = Copper/Copper Condenser and Aluminum/Copper Evaporator F = Copper/Copper Condenser and Evaporator	Condenser / Evaporator Coil Configuration													
A = Economizer control for EconoMi\$er IV and all others (except factory-installed EconoMi\$er X) B = Economizer control for factory-installed for EconoMi\$er X	Economizer Control													

Capacity ratings

RGV AHRI RATINGS

UNIT	COOLING STAGES	NOMINAL CAPACITY (TONS)	NET COOLING CAPACITY (MBH)	TOTAL POWER (kW)	EER	IEER WITH 2-SPEED INDOOR FAN MOTOR	AHRI RATING CFM
RGV090	2	7.5	86.0	7.7	11.2	15.0	2650
RGV102	2	8.5	98.0	8.8	11.2	15.0	3400
RGV120	2	10.0	118.0	10.7	11.0	15.0	3500
RGV150	2	12.5	132.0	12.9	10.2	15.0	3750
RGV180	2	15.0	174.0	16.1	10.8	14.5	5250

LEGEND

AHRI — Air-Conditioning, Heating and Refrigeration Institute
EER — Energy Efficiency Ratio
IEER — Integrated Energy Efficiency Ratio

NOTES:

1. Rated in accordance with AHRI Standards 340/360.
2. Rating are based on:
Cooling Standard: 80°F (27°C) db, 67°F (19°C) wb indoor air temperature and 95°F (35°C) db outdoor air temperature.
IEER Standard: A measure that expresses cooling part-load EER efficiency for commercial unitary air-conditioning and heat pump equipment on the basis of weighted operation at various load capacities.
3. All RGV090-180 units comply with ASHRAE 90.1-2019 (American Society of Heating, Refrigerating, and Air-Conditioning Engineers) and DOE-2023 (Department of Energy) Energy Standard for minimum IEER requirements.
4. RGV090-180 units comply with US Energy Policy Act (2005). To evaluate code compliance requirements, refer to state and local codes.



RAV AHRI RATINGS

UNIT	COOLING STAGES	NOMINAL CAPACITY (TONS)	NET COOLING CAPACITY (MBH)	TOTAL POWER (kW)	EER	IEER WITH 2-SPEED INDOOR FAN MOTOR	AHRI RATING CFM
RAV090	2	7.5	86.0	7.5	11.4	15.2	2650
RAV102	2	8.5	98.0	8.6	11.4	15.2	3400
RAV120	2	10.0	118.0	10.5	11.2	15.2	3500
RAV150	2	12.5	133.0	12.8	10.4	15.2	3750
RAV180	2	15.0	174.0	15.8	11.0	14.7	5250

LEGEND

AHRI — Air-Conditioning, Heating and Refrigeration Institute
EER — Energy Efficiency Ratio
IEER — Integrated Energy Efficiency Ratio

NOTES:

1. Rated in accordance with AHRI Standards 340/360.
2. Rating are based on:
Cooling Standard: 80°F (27°C) db, 67°F (19°C) wb indoor air temperature and 95°F (35°C) db outdoor air temperature.
IEER Standard: A measure that expresses cooling part-load EER efficiency for commercial unitary air-conditioning and heat pump equipment on the basis of weighted operation at various load capacities.
3. All RAV090-180 units comply with ASHRAE 90.1-2019 (American Society of Heating, Refrigerating, and Air-Conditioning Engineers) and DOE-2023 (Department of Energy) Energy Standard for minimum IEER requirements.
4. RAV090-180 units comply with US Energy Policy Act (2005). To evaluate code compliance requirements, refer to state and local codes.



Capacity ratings (cont)

SOUND RATINGS TABLE

RGV/RAV UNIT	COOLING STAGES	OUTDOOR SOUND (dB) at 60 Hz								
		A-WEIGHTED	63	125	250	500	1000	2000	4000	8000
090	2	79	85.6	84.7	80.5	76.0	72.4	68.0	62.8	59.3
102	2	79	85.6	84.7	80.5	76.0	72.4	68.0	62.8	59.3
120	2	79	85.6	84.7	80.5	76.0	72.4	68.0	62.8	59.3
150	2	79	85.6	84.7	80.5	76.0	72.4	68.0	62.8	59.3
180	2	87	87.0	85.2	84.6	84.9	82.8	78.4	75.3	72.9

LEGEND

dB — Decibel

NOTES:

1. Outdoor sound data is measured in accordance with AHRI.
2. Measurements are expressed in terms of sound power. Do not compare these values to sound pressure values because sound pressure depends on specific environmental factors which normally do not match individual applications. Sound power values are independent of the environment and therefore more accurate.
3. A-weighted sound ratings filter out very high and very low frequencies, to better approximate the response of "average" human ear. A-weighted measurements for RGV/RAV units are taken in accordance with AHRI.

MINIMUM - MAXIMUM AIRFLOW RATINGS (CFM) — NATURAL GAS AND PROPANE

UNIT	HEAT LEVEL	COOLING			HEATING ^a	
		MINIMUM 2-SPEED AIRFLOW (LOW SPEED)	MINIMUM 2-SPEED AIRFLOW (HIGH SPEED)	MAXIMUM AIRFLOW CFM	MINIMUM AIRFLOW CFM	MAXIMUM AIRFLOW CFM
RGV090	LOW	1350	2250	3750	1730	3800
	MED				2100	3900
	HIGH				2240	4200
RGV102	LOW	1275	2550	4250	1730	4750
	MED				2100	4560
	HIGH				2240	4800
RGV120	LOW	1800	3000	5000	2100	5470
	MED				2580	5600
	HIGH				2710	5420
RGV150	LOW	2250	3750	6250	2100	6830
	MED				2580	6720
	HIGH				2710	6330
RGV180	LOW	2970	4500	7500	2450	9000
	MED				3000	9000
	HIGH				4040	7500

NOTE(S):

- a. Heating rating values are identical for aluminum heat exchangers and stainless steel heat exchangers.

MINIMUM - MAXIMUM AIRFLOW RATINGS (CFM) — COOLING UNITS AND ACCESSORY ELECTRIC HEAT

UNIT	COOLING			ELECTRIC HEAT ^a	
	MINIMUM 2-SPEED AIRFLOW (LOW SPEED)	MINIMUM 2-SPEED AIRFLOW (HIGH SPEED)	MAXIMUM AIRFLOW CFM	MINIMUM AIRFLOW CFM	MAXIMUM AIRFLOW CFM
RAV090	1350	2250	3750	2250	3750
RAV102	1275	2550	4250	2550	4250
RAV120	1800	3000	5000	3000	5000
RAV150	2250	3750	6250	3750	6250
RAV180	2970	4500	7500	4500	7500

NOTE(S):

- a. Electric heat modules and single point kits are available as field-installed accessories for RAV units.

Capacity ratings (cont)

HEAT RATING TABLE — NATURAL GAS AND PROPANE

UNIT	GAS HEAT	AL/SS HEAT EXCHANGER		TEMPERATURE RISE (°F)	THERMAL EFFICIENCY (%)
		INPUT/OUTPUT STAGE 1 (MBH)	INPUT/OUTPUT STAGE 2 (MBH)		
RGV090	LOW	-/-	125/103	25-55	82
	MED	120/98	180/148	35-65	82
	HIGH	180/146	224/181	40-75	81
RGV102	LOW	-/-	125/103	20-55	82
	MED	120/98	180/148	30-65	82
	HIGH	180/146	224/181	35-75	81
RAV120	LOW	120/98	180/148	25-65	82
	MED	180/146	224/181	30-65	81
	HIGH	200/164	250/205	35-70	82
RGV150	LOW	120/98	180/148	20-65	82
	MED	180/146	224/181	25-65	81
	HIGH	200/160	250/205	30-70	82
RGV180	LOW	144/118	180/146	15-55	81
	MED	192/156	240/195	20-60	81
	HIGH	280/224	350/284	35-65	81

LEGEND

MBH — Btuh in thousands

Physical data

RGV/RAV 7.5 TO 8.5 TON PHYSICAL DATA

RGV/RAV UNIT	RGV/RAV090**2/3/5/6	RGV/RAV090**4/7	RGV/RAV102**2/3/5/6	RGV/RAV102**4/7
NOMINAL TONS	7.5	7.5	8.5	8.5
BASE UNIT OPERATING WT (lb) RGV/RAV^a	787/743	787/743	868/805	868/805
REFRIGERATION SYSTEM				
No. Circuits/No. Compressors/Type	1 / 2 / Scroll	1 / 2 / Scroll	1 / 2 / Scroll	1 / 2 / Scroll
R-410A Charge (lb-oz)	13-3	—	14-0	—
Hot Gas Re-Heat R-410A Charge (lb-oz)	—	19-5	—	21-0
Metering Device	TXV	TXV	TXV	TXV
Hot Gas Re-Heat Metering Device	—	TXV	—	TXV
High-Pressure Trip/Reset (psig)	630/505	630/505	630/505	630/505
Low-Pressure Trip/Reset (psig)	54/117	54/117	54/117	54/117
EVAPORATOR COIL				
Material (Tube/Fin)	Cu/Al	Cu/Al	Cu/Al	Cu/Al
Coil Type	3/8 in. RTPF	3/8 in. RTPF	3/8 in. RTPF	3/8 in. RTPF
Rows/FPI	3/15	3/15	4/15	4/15
Total Face Area (ft ²)	8.9	8.9	8.9	8.9
Condensate Drain Connection Size	3/4 in.	3/4 in.	3/4 in.	3/4 in.
CONDENSER COIL				
Material	Cu/Al	Cu/Al	Cu/Al	Cu/Al
Coil Type	5/16 in. RTPF	5/16 in. RTPF	5/16 in. RTPF	5/16 in. RTPF
Rows/FPI	2/18	2/18	2/18	2/18
Total Face Area (ft ²)	20.5	20.5	21.4	21.4
HOT GAS RE-HEAT COIL				
Material	—	Cu/Al	—	Cu/Al
Coil Type	—	5/16 in. RTPF	—	5/16 in. RTPF
Rows/FPI	—	2/18	—	2/18
Total Face Area (ft ²)	—	6.0	—	8.0
EVAPORATOR FAN AND MOTOR				
Standard/Medium Static				
Motor Qty / Drive Type	1 / Direct	1 / Direct	1 / Direct	1 / Direct
Max Cont bhp	2.4	2.4	2.4	2.4
Range (rpm)	250-2000	250-2000	250-2000	250-2000
Fan Qty/Type	1/Vane Axial	1/Vane Axial	1/Vane Axial	1/Vane Axial
Fan Diameter (in.)	22	22	22	22
High Static				
Motor Qty / Drive Type	1 / Direct	1 / Direct	1 / Direct	1 / Direct
Max Cont bhp	3	3	3	3
Range (rpm)	250-2200	250-2200	250-2200	250-2200
Fan Qty/Type	1/Vane Axial	1/Vane Axial	1/Vane Axial	1/Vane Axial
Fan Diameter (in.)	22	22	22	22
CONDENSER FAN AND MOTOR				
Qty / Motor Drive Type	2 / Direct	2 / Direct	2 / Direct	2 / Direct
Motor hp/rpm	1/4 / 1100	1/4 / 1100	1/4 / 1100	1/4 / 1100
Fan Diameter (in.)	22	22	22	22
FILTERS				
RA Filter Qty / Size (in.)	4 / 16x20x2	4 / 16x20x2	4 / 16x20x2	4 / 16x20x2
OA Inlet Screen Qty / Size (in.)	1 / 20x24x1	1 / 20x24x1	1 / 20x24x1	1 / 20x24x1

NOTE(S):

a. Base unit operating weight does not include weight of options.

LEGEND

bhp — Brake Horsepower
FPI — Fins Per Inch
OA — Outdoor Air
RA — Return Air

Physical data (cont)

RGV/RAV 10 TO 12.5 TON PHYSICAL DATA

RGV/RAV UNIT	RGV/RAV120**2/3/5/6	RGV/RAV120**4/7	RGV/RAV150**2/3/5/6	RGV/RAV150**4/7
NOMINAL TONS	10.0	10.0	12.5	12.5
BASE UNIT OPERATING WT (lb) RGV/RAV^a	878/815	878/815	1041/978	1041/978
REFRIGERATION SYSTEM				
No. Circuits/No. Compressors/Type	1 / 2 / Scroll	1 / 2 / Scroll	1 / 2 / Scroll	1 / 2 / Scroll
R-410A Charge (lb-oz)	15-3	—	19-8	—
Hot Gas Re-Heat R-410A Charge (lb-oz)	—	23-3	—	28-6
Metering Device	TXV	TXV	TXV	TXV
Hot Gas Re-Heat Metering Device	—	TXV	—	TXV
High-Pressure Trip/Reset (psig)	630/505	630/505	630/505	630/505
Low-Pressure Trip/Reset (psig)	54/117	54/117	54/117	54/117
EVAPORATOR COIL				
Material (Tube/Fin)	Cu/Al	Cu/Al	Cu/Al	Cu/Al
Coil Type	3/8 in. RTPF	3/8 in. RTPF	3/8 in. RTPF	3/8 in. RTPF
Rows/FPI	4/15	4/15	4/15	4/15
Total Face Area (ft ²)	11.1	11.1	11.1	11.1
Condensate Drain Connection Size	3/4 in.	3/4 in.	3/4 in.	3/4 in.
CONDENSER COIL				
Material	Cu/Al	Cu/Al	Cu/Al	Cu/Al
Coil Type	5/16 in. RTPF	5/16 in. RTPF	5/16 in. RTPF	5/16 in. RTPF
Rows/FPI	2/18	2/18	3/18	3/18
Total Face Area (ft ²)	25.1	25.1	25.1	25.1
HOT GAS RE-HEAT COIL				
Material	—	Cu/Al	—	Cu/Al
Coil Type	—	5/16 in. RTPF	—	5/16 in. RTPF
Rows/FPI	—	2/18	—	2/18
Total Face Area (ft ²)	—	8.0	—	8.0
EVAPORATOR FAN AND MOTOR				
Standard/Medium Static				
Motor Qty / Drive Type	1 / Direct	1 / Direct	1 / Direct	1 / Direct
Max Cont bhp	2.4	2.4	3	3
Range (rpm)	250-2000	250-2000	250-2200	250-2200
Fan Qty / Type	1 / Vane Axial	1 / Vane Axial	1 / Vane Axial	1 / Vane Axial
Fan Diameter (in.)	22	22	22	22
High Static				
Motor Qty / Drive Type	1 / Direct	1 / Direct	1 / Direct	1 / Direct
Max Cont bhp	5	5	5	5
Range (rpm)	250-2200	250-2200	250-2200	250-2200
Fan Qty / Type	1 / Vane Axial	1 / Vane Axial	1 / Vane Axial	1 / Vane Axial
Fan Diameter (in.)	22	22	22	22
CONDENSER FAN AND MOTOR				
Qty / Motor Drive Type	2 / Direct	2 / Direct	1 / Direct	1 / Direct
Motor hp / rpm	1/4 / 1100	1/4 / Multiple Speeds	1 / Multiple Speeds	1 / Multiple Speeds
Fan Diameter (in.)	22	22	30	30
FILTERS				
RA Filter Qty / Size (in.)	4 / 20x20x2	4 / 20x20x2	4 / 20x20x2	4 / 20x20x2
OA Inlet Screen Qty / Size (in.)	1 / 20x24x1	1 / 20x24x1	1 / 20x24x1	1 / 20x24x1

NOTE(S):

a. Base unit operating weight does not include weight of options.

LEGEND

bhp — Brake Horsepower
FPI — Fins Per Inch
OA — Outdoor Air
RA — Return Air

Physical data (cont)

RGV/RAV 15 TON PHYSICAL DATA

RGV/RAV UNIT	RGV/RAV180**2/3/5/6	RGV/RAV180**4/7
NOMINAL TONS	15.0	15.0
BASE UNIT OPERATING WT (lb) RGV/RAV^a	1408/1325	1408/1325
REFRIGERATION SYSTEM		
No. Circuits/No. Compressors/Type	1 / 2 / Scroll	1 / 2 / Scroll
R-410A Charge (lb-oz)	24-0	34-0
Hot Gas Re-Heat R-410A Charge (lb-oz)	—	34-0
Metering Device	TXV	TXV
Hot Gas Re-Heat Metering Device	—	—
High-Pressure Trip/Reset (psig)	630/505	630/505
Low-Pressure Trip/Reset (psig)	54/117	54/117
EVAPORATOR COIL		
Material (Tube/Fin)	Cu/Al	Cu/Al
Coil Type	3/8 in. RTPF	3/8 in. RTPF
Rows/FPI	3/15	3/15
Total Face Area (ft ²)	17.5	17.5
Condensate Drain Connection Size	3/4 in.	3/4 in.
CONDENSER COIL		
Material	Cu/Al	Cu/Al
Coil Type	5/16 in. RTPF	5/16 in. RTPF
Rows/FPI	2/18	2/18
Total Face Area (ft ²)	46.2	46.2
HOT GAS RE-HEAT COIL		
Material	—	Cu/Al
Coil Type	—	5/16 in. RTPF
Rows/FPI	—	2/18
Total Face Area (ft ²)	—	8.0
EVAPORATOR FAN AND MOTOR		
Standard/Medium Static		
Motor Qty / Drive Type	1 / Direct	1 / Direct
Max Cont bhp	3	3
Range (rpm)	250-2000	250-2000
Fan Qty / Type	1 / Vane Axial	1 / Vane Axial
Fan Diameter (in.)	22	22
High Static		
Motor Qty / Drive Type	1 / Direct	1 / Direct
Max Cont bhp	5	5
Range (rpm)	250-2000	250-2000
Fan Qty / Type	1 / Vane Axial	1 / Vane Axial
Fan Diameter (in.)	22	22
CONDENSER FAN AND MOTOR		
Qty / Motor Drive Type	3 / Direct	3 / Direct
Motor hp / rpm	1/4 / 1100	1/4 / 1100
Fan Diameter (in.)	22	22
FILTERS		
RA Filter Qty / Size (in.)	6 / 18x24x2	6 / 18x24x2
OA Inlet Screen Qty / Size (in.)	Vertical: 2 / 24x27x1 Horizontal: 1 / 30x39x1	Vertical: 2 / 24x27x1 Horizontal: 1 / 30x39x1

NOTE(S):

a. Base unit operating weight does not include weight of options.

LEGEND

bhp — Brake Horsepower
FPI — Fins Per Inch
OA — Outdoor Air
RA — Return Air

Physical data (cont)

RGV 7.5 TO 15 TON GAS HEAT DATA

RGV UNIT	RGV090	RGV102	RGV120	RGV150	RGV180
NOMINAL TONS	7.5	8.5	10.0	12.5	15
GAS CONNECTION					
No. of Gas Valves	1	1	1	1	1
Natural Gas Supply Line Pressure (in. wg)/(psig)	4-13 / 0.18-0.47	4-13 / 0.18-0.47	4-13 / 0.18-0.47	4-13 / 0.18-0.47	4-13 / 0.18-0.47
Liquid Propane Supply Line Pressure (in. wg)/(psig)	11-13 / 0.40-0.47	11-13 / 0.40-0.47	11-13 / 0.40-0.47	11-13 / 0.40-0.47	11-13 / 0.40-0.47
HEAT ANTICIPATOR SETTING (AMPS)					
First Stage	0.14	0.14	0.14	0.14	0.14
Second Stage	0.14	0.14	0.14	0.14	0.14
NATURAL GAS HEAT					
LOW					
No. of Stages / No. of Burners (total)	1 / 3	1 / 3	2 / 4	2 / 4	2 / 6
Connection Size	1/2 in. NPT	1/2 in. NPT	3/4 in. NPT	3/4 in. NPT	3/4 in. NPT
Rollout Switch Opens / Closes (°F)	195 / 115	195 / 115	195 / 115	195 / 115	196 / 115
Temperature Rise (°F)	25-55	20-55	25-65	20-65	15-55
MEDIUM					
No. of Stages / No. of Burners (total)	2 / 4	2 / 4	2 / 5	2 / 5	2 / 8
Connection Size	3/4 in. NPT	3/4 in. NPT	3/4 in. NPT	3/4 in. NPT	3/4 in. NPT
Rollout Switch Opens / Closes (°F)	195 / 115	195 / 115	195 / 115	195 / 115	197 / 115
Temperature Rise (°F)	35-65	30-65	30-65	25-65	20-60
HIGH					
No. of Stages / No. of Burners (total)	2 / 5	2 / 5	2 / 5	2 / 5	2 / 10
Connection Size	3/4 in. NPT	3/4 in. NPT	3/4 in. NPT	3/4 in. NPT	3/4 in. NPT
Rollout Switch Opens / Closes (°F)	195 / 115	195 / 115	195 / 115	195 / 115	198 / 115
Temperature Rise (°F)	40-75	35-75	35-70	30-70	35-65
LIQUID PROPANE HEAT					
LOW					
No. of Stages / No. of Burners (total)	1 / 3	1 / 3	2 / 4	2 / 4	2 / 6
Connection Size	1/2 in. NPT	1/2 in. NPT	3/4 in. NPT	3/4 in. NPT	3/4 in. NPT
Rollout Switch Opens / Closes (°F)	195 / 115	195 / 115	195 / 115	195 / 115	196 / 115
Temperature Rise (°F)	25-55	20-55	25-65	20-65	15-55
MEDIUM					
No. of Stages / No. of Burners (total)	1 / 3	1 / 3	2 / 5	2 / 5	2 / 8
Connection Size	1/2 in. NPT	1/2 in. NPT	1/2 in. NPT	1/2 in. NPT	3/4 in. NPT
Rollout Switch Opens / Closes (°F)	195 / 115	195 / 115	195 / 115	195 / 115	197 / 115
Temperature Rise (°F)	35-65	30-65	30-65	25-65	20-60
HIGH					
No. of Stages / No. of Burners (total)	2 / 5	2 / 5	2 / 5	2 / 5	2 / 10
Connection Size	3/4 in. NPT	3/4 in. NPT	3/4 in. NPT	3/4 in. NPT	3/4 in. NPT
Rollout Switch Opens / Closes (°F)	195 / 115	195 / 115	195 / 115	195 / 115	198 / 115
Temperature Rise (°F)	40-75	35-75	35-70	30-70	35-65

Options and accessories

ITEM	OPTION ^a	ACCESSORY ^b
GAS HEAT (RGV units only)		
Low, Medium or High Gas Heat — Aluminized Heat Exchanger	X	
Low, Medium or High Gas Heat — Stainless Steel Heat Exchanger	X	
Propane Conversion Kit		X
High Altitude Conversion Kit		X
Flue Discharge Deflector		X
Flue Shield (090-150 sizes only)		X
ELECTRIC HEAT (RAV units only)		
Electric Resistance Heaters		X
Single Point Kits		X
CABINET		
Thru-the-Base electrical or gas-line connections	X	X
Hinged Access Panels	X	
UV-C Ultraviolet Lamp ^c		X
MERV-13, 2 in. Filters		X
MERV-8, 2 in. Filters		X
4 in. Filter Rack (filters not included)		X
Disconnect Switch Bracket ^d		X
Supply Duct Cover ^d		X
COIL OPTIONS		
Cu/Cu indoor and/or outdoor coils	X	
Pre-coated outdoor coils	X	
Premium, E-coated outdoor coils	X	
HUMIDITY CONTROL		
Hot Gas Re-Heat Dehumidification System	X	
CONDENSER PROTECTION		
Condenser coil hail guard (louvered design)	X	X
CONTROLS		
Thermostats, temperature sensors, and subbases		X
Smoke detector (supply and/or return air)	X	X
Horn Strobe Annunciator ^e		X
Time Guard II compressor delay control circuit		X

ITEM	OPTION ^a	ACCESSORY ^b
Phase Monitor	X	X
ECONOMIZERS AND OUTDOOR AIR DAMPERS		
EconoMi\$er X for electromechanical controls, complies with FDD (Low and Ultra Low Leak damper models) ^f	X	X
EconoMi\$er [®] IV for electromechanical controls — Non FDD (Standard air leak damper models) ^f		X
Motorized 2-position outdoor-air damper		X
Manual outdoor-air damper (25% and 50%)		X
Barometric relief ^g	X	X
Power exhaust — prop design		X
Condensate Overflow switch	X	X
ECONOMIZER SENSORS AND IAQ DEVICES		
Single dry bulb temperature sensors ^h	X	X
Differential dry bulb temperature sensors ^h		X
Differential enthalpy sensors ^h		X
CO ₂ sensor (wall, duct, or unit mounted) ^h	X	X
INDOOR MOTOR AND DRIVE		
Multiple motor and drive packages	X	
LOW AMBIENT CONTROLS		
Winter start kit ⁱ		X
Low Ambient controller to 0°F (-18°C) ^j		X
POWER OPTIONS		
Convenience outlet (powered)	X	
Convenience outlet (unpowered)	X	
Convenience outlet, 20 amp (unpowered)		X
Non-fused disconnect ^j	X	
ROOF CURBS		
Roof curb 14 in. (356 mm)		X
Roof curb 24 in. (610 mm)		X

NOTE(S):

- Factory-installed option.
- Field-installed accessory.
- UV-C kits can not be used on units with Hot Gas Re-Heat system.
- For size 180 units only.
- Requires a field-supplied 24V transformer for each application. See price pages for details.
- FDD (Fault Detection and Diagnostic) capability per California Title 24 section 120.2.
- Included with economizer.
- Sensors used to optimize economizer performance.
- See application data for assistance.
- Non-fused disconnect switch cannot be used when unit electrical rating exceeds:
 - Sizes 090-150: 80 amps, all voltages
 - Size 180: 100 amps, all voltages.

Options and accessories (cont)

Factory-installed options

Economizer (dry-bulb or enthalpy)

Economizers save money. They bring in fresh, outside air for ventilation; and provide cool, outside air to cool your building. This is the preferred method of low-ambient cooling. When coupled to CO₂ sensors, economizers can provide even more savings by coupling the ventilation air to only that amount required.

Economizers are available, installed and tested by the factory, with either enthalpy or dry-bulb temperature inputs. Additional sensors are available as accessories to optimize the economizers. Economizers include a powered exhaust system to help equalize building pressures.

Economizers can be factory-installed or easily field-installed.

Unit mounted CO₂ sensor

The CO₂ sensor works with the economizer to intake only the correct amount of outside air for ventilation. As occupants fill your building, the CO₂ sensor detects their presence through increasing CO₂ levels, and opens the economizer appropriately. When the occupants leave, the CO₂ levels decrease, and the sensor appropriately closes the economizer. This intelligent control of the ventilation air, called demand controlled ventilation (DCV), reduces the overall load on the rooftop, saving money. It is also available as a field-installed accessory.

Smoke detector (supply and/or return air)

Trust the experts. Smoke detectors make your application safer and your job easier. Our smoke detectors immediately shut down the rooftop unit when smoke is detected. They are available, installed by the factory, for supply air, return air, or both.

Optional Hot Gas Re-Heat dehumidification system

The Hot Gas Re-Heat dehumidification system is an all-inclusive factory-installed option that can be ordered with any RGV/RAV090-180 rooftop unit.

This system expands the envelope of operation of RGV/RAV rooftop products to provide unprecedented flexibility to meet year round comfort conditions.

The Hot Gas Re-Heat dehumidification system has a unique dual operational mode setting. The Hot Gas Re-Heat system provides greater dehumidification of the occupied space by two modes of dehumidification operations in addition to its normal design cooling mode.

The RGV/RAV090-180 rooftop coupled with the Hot Gas Re-Heat system is capable of operating in normal design cooling mode, sub-cooling mode, and hot gas reheat mode. Normal design cooling mode is when the unit will operate under its normal sequence of operation by cycling compressors to maintain comfort conditions.

Sub-cooling mode will operate to satisfy part load type conditions when the space requires combined sensible and a higher proportion of latent load control. Hot Gas Reheat mode will operate when outdoor temperatures diminish and the need for latent capacity is required for sole

humidity control Hot Gas Reheat mode will provide neutral air for maximum dehumidification operation.

NOTE: Hot Gas Re-Heat system includes Low Ambient controller.

Thru-the-base connections

Thru-the-base connections, available as a factory option, are necessary to ensure proper connection and seal when routing wire and piping through the rooftop's base-pan and curb. These couplings eliminate roof penetration and should be considered for gas lines, main power lines, as well as control power.

Hinged access panels

Allows access to unit's major components with specifically designed hinged access panels. Panels are filter, control box access indoor fan motor access.

Cu/Cu (indoor) coils

Copper fins and copper tubes are mechanically bonded to copper tubes and copper tube sheets. A polymer strip prevents coil assembly from contacting the sheet metal coil pan to minimize potential for galvanic corrosion between coil and pan.

E-coated (outdoor and indoor) coils

A flexible epoxy polymer coating uniformly applied to all coil surface areas without material bridging between fins. Coating process shall ensure complete coil encapsulation of tubes, fins and headers.

Pre-coated outdoor coils

A durable epoxy-phenolic coating to provide protection in mildly corrosive coastal environments. The coating minimizes galvanic action between dissimilar metals. Coating is applied to the aluminum fin stock prior to the fin stamping process to create an inert barrier between the aluminum fin and copper tube.

Condenser coil hail guard

Sleek, louvered panels protect the condenser coil from hail damage, foreign objects, and incidental contact.

Stainless steel heat exchanger (RGV units only)

The stainless steel heat exchanger option provides the tubular heat exchanger be made out of a minimum 20 gauge type 409 stainless steel for applications where the mixed air to the heat exchanger is expected to drop below 45°F (7°C). Stainless steel may be specified on applications where the presence of airborne contaminants require its use (applications such as paper mills) or in area with very high outdoor humidity that may result in severe condensation in the heat exchanger during cooling operation.

Convenience outlet (powered or un-powered)

Reduce service and/or installation costs by including a convenience outlet in your specification. We install this service feature at our factory. Provides a convenient, 15 amp, 115v GFCI receptacle with "Wet in Use" cover. The "powered" option allows the installer to power the outlet from the line side of the disconnect or load side as

Options and accessories (cont)

required by code. The “unpowered” option is to be powered from a separate 115/120v power source.

The unpowered convenience outlet is available as a 15 amp factory-installed option or a 20 amp field-installed accessory.

Non-fused disconnect

This OSHA-compliant, factory-installed, safety switch allows a service technician to locally secure power to the rooftop. When selecting a factory-installed non-fused disconnect, note they are sized for the unit as ordered from the factory. The sizing of these do not accommodate field-installed items such as power exhaust devices, etc. If field installing electric heat with factory-installed non-fused disconnect switch, a single point kit may or may not be required.

Condensate overflow switch

This sensor and related controller monitors the condensate level in the drain pan and shuts down compression operation when overflow conditions occur. It includes:

- Indicator light — solid red (more than 10 seconds on water contact — compressors disabled), blinking red (sensor disconnected)

- 10-second delay to break — eliminates nuisance trips from splashing or waves in pan (sensor needs 10 seconds of constant water contact before tripping)
- Disables the compressors operation when condensate plug is detected, but still allows fans to run for economizer.

Power exhaust with barometric relief

Superior internal building pressure control. This field-installed accessory may eliminate the need for costly, external pressure control fans.

Filter maintenance indicator

When the optional factory-installed filter maintenance indicator is used, a factory-installed differential pressure switch measures pressure drop across the outside air filter and activates a field-supplied dry contact indicator when the pressure differential exceeds the adjustable switch setpoint.

Options and accessories (cont)

Field-installed accessories

Condenser coil hail guard

Sleek, louvered panels protect the condenser coil from hail damage, foreign objects, and incidental contact. This can be purchased as a factory-installed option or as a field-installed accessory.

Differential enthalpy sensor

The differential enthalpy sensor is comprised of an outdoor and return air enthalpy sensors to provide differential enthalpy control. The sensor allows the unit to determine if outside air is suitable for free cooling.

Wall or duct mounted CO₂ sensor

The IAQ sensor shall be available in duct or wall mount. The sensor provides demand ventilation indoor air quality (IAQ) control.

Propane conversion kit (RGV units only)

Convert your gas heat rooftop from standard natural gas operation to Propane using this field-installed kit.

High altitude conversion kit (RGV units only)

High altitudes have less oxygen, which affects the fuel/air mixture in heat exchangers. In order to maintain a proper fuel/air mixture, heat exchangers operating in altitudes above 2000 ft (610 m) require different orifices. To select the correct burner orifices or determine the heat capacity for a high altitude application, use either the selection software, or the unit's service manual. High altitudes have less oxygen, which means heat exchangers need less fuel. The new gas orifices in this field-installed kit make the necessary adjustment for high altitude applications. They restore the optimal fuel to air mixture and maintain healthy combustion on altitudes above 2000 ft (610 m).

NOTE: Typical natural gas heating value ranges from 975 to 1050 Btu/ft³ at sea level nationally. The heating value goes down approximately 1.7% per every thousand feet elevation. Standard factory orifices can typically be used up to 2000 ft (610 m) elevation without any operational issues.

Flue discharge deflector (RGV units only)

The flue discharge deflector is a useful accessory when flue gas recirculation is a concern. By venting the flue discharge upwards, the deflector minimizes the chance for a neighboring unit to intake the flue exhaust.

4 in. filter rack kit

The 4 in. filter rack accessory kit is designed to hold 4 in. MERV-8 or MERV-13 filters. Filters not included in kit.

MERV-13 2 in. return air filters

This kit includes MERV-13 2 in. filters (qty 4) to accommodate unit filter rack size.

MERV-8 2 in. return air filters

This kit includes MERV-8 2 in. filters (qty 4) to accommodate unit filter rack size.

UV-C ultraviolet lamp kit

High-output, low temperature ultraviolet lamp. Accessory kit includes lamp, interlock switch, mounting brackets, necessary wires, wire ties, screws and labels to field install kit in unit return air plenum. Separate dedicated 115v power source required. See appropriate installation instructions.

Note: UV-C kit can not be used on units with Hot Gas Re-Heat system.

Phase monitor protection

The Phase Monitor Control will monitor the sequence of three phase electrical system to provide a phase reversal protection; and monitor the three phase voltage inputs to provide a phase loss protection for the three phase device. It will work on either a Delta or Wye power connection.

Winter start kit

The winter start kit extends the low ambient limit of your rooftop to 25°F (−4°C). The kit bypasses the low pressure switch, preventing nuisance tripping of the low pressure switch. Other low ambient precautions may still be prudent.

Low ambient controller

The low ambient controller is a head pressure controller kit that is designed to maintain the unit's condenser head pressure during periods of low ambient cooling operation. This device should be used as an alternative to economizer free cooling when economizer usage is either not appropriate or desired. The low ambient controller will either cycle the outdoor fan motors or operate them at reduced speed to maintain the unit operation, depending on the model. This controller allows cooling operation down to 0°F (−18°C) ambient conditions.

NOTE: 0°F (−18°C) is standard on size 150 models.

Roof curb (14 in./356 mm or 24 in./610 mm)

Full perimeter roof curb with exhaust capability provides separate air streams for energy recovery from the exhaust air without supply air contamination.

Filter status indicator accessory

Monitors static pressure across supply and exhaust filters and provides indication when filters become clogged.

Power exhaust

Superior internal building pressure control. This field-installed accessory may eliminate the need for costly, external pressure control fans.

Manual OA damper

Manual outdoor air dampers are an economical way to bring in ventilation air. The dampers are available in 25% and 50% versions.

NOTE: See application tip "ROOFTOP-18-01" prior to use of this damper on 090-180 size models.

Motorized 2-position damper

The 2-position, motorized outdoor air damper admits up to 100% outside air. Using reliable, gear-driven technology, the 2-position damper opens to allow ventilation air

Options and accessories (cont)

and closes when the rooftop stops, stopping unwanted infiltration.

NOTE: See application tip “ROOFTOP-18-01” prior to use of this damper on 090-180 size models.

Electric heaters

A full-line of field-installed accessory heaters are offered. The heaters are very easy to use, install and are all pre-engineered and certified.

Time Guard II control circuit

This accessory protects your compressor by preventing short-cycling in the event of some other failure, prevents the compressor from restarting for 30 seconds after stopping.

Disconnect switch bracket

Provides a pre-engineered and sized mounting bracket for applications requiring a unit mounted fused and non-fused disconnect of greater than 100 amps. Bracket assures that no damage will occur to coils when mounting with screws and other fasteners (180 size only).

OPTIONS AND ACCESSORY WEIGHTS^a

OPTION / ACCESSORY NAME	RGV/RAV UNIT WEIGHT									
	090		102		120		150		180	
	lb	kg	lb	kg	lb	kg	lb	kg	lb	kg
Hot Gas Re-Heat System ^b	25	12	34	16	34	16	34	16	55	25
Power Exhaust — Vertical	75	34	75	34	75	34	75	34	85	39
Power Exhaust — Horizontal	30	14	30	14	30	14	30	14	75	34
EconoMi\$er® (X or IV)	55	25	55	25	55	25	55	25	85	39
2-Position Damper	58	26	58	26	58	26	58	26	65	29
Manual Damper	18	8	18	8	18	8	18	8	25	11
Medium Gas Heat (RGV units only)	15	7	15	7	18	8	18	8	18	8
High Gas Heat (RGV units only)	30	14	30	14	27	12	27	12	36	16
Hail Guard (louvered)	17	8	17	8	17	8	17	8	44	20
Cu/Cu Condenser Coil	85	39	85	39	100	46	150	68	180	82
Cu/Cu Evaporator Coil	50	23	100	46	100	46	100	46	120	55
Roof Curb (14 in. curb)	143	65	143	65	143	65	143	65	180	82
Roof Curb (24 in. curb)	245	112	245	112	245	112	245	112	255	116
CO ₂ Sensor	2	1	2	1	2	1	2	1	2	1
Flue Discharge Deflector	7	3	7	3	7	3	7	3	7	3
Optional Indoor Motor ^c	10	5	10	5	10	5	15	7	0	0
Low Ambient Controller	9	4	9	4	9	4	9	4	9	4
Winter Start Kit	5	2	5	2	5	2	5	2	5	2
Return Air Smoke Detector	7	3	7	3	7	3	7	3	7	3
Supply Air Smoke Detector	7	3	7	3	7	3	7	3	7	3
Fan Filter Switch	2	1	2	1	2	1	2	1	2	1
Non-Fused Disconnect	15	7	15	7	15	7	15	7	15	7
Powered Convenience Outlet	36	16	36	16	36	16	36	16	36	16
Unpowered Convenience Outlet	4	2	4	2	4	2	4	2	4	2
Enthalpy Sensor	2	1	2	1	2	1	2	1	2	1
Differential Enthalpy Sensor	3	1	3	1	3	1	3	1	3	1

NOTE(S):

- a. Where multiple variations are available, the heaviest combination is listed.
- b. For Hot Gas Re-Heat system, add Low Ambient controller weight.
- c. Add the Optional Indoor Motor weight to the weight of the base unit.

RGV090-120 BASE UNIT DIMENSIONS

- NOTES:
1. DIMENSIONS ARE IN INCHES. DIMENSIONS IN [] ARE IN MILLIMETERS.
 2. CENTER OF GRAVITY
 3. DIRECTION OF AIR FLOW
 4. ALL VIEW DRAWN USING 3RD ANGLE

UNIT	OUTDOOR COIL TYPE	J	K	H
RGV-090	R1PF	41 1/4 [1048]	33 3/4 [857]	15 7/8 [403]
RGV-102	R1PF	49 3/8 [1253]	36 3/8 [925]	15 7/8 [403]
RGV-120	R1PF	49 3/8 [1253]	36 3/8 [925]	15 7/8 [403]

R1PF - ROUND TUBE, PLATE FIN (COPPER/ALUM)



THIS DOCUMENT IS THE PROPERTY OF CARRIER CORPORATION AND IS DELIVERED UPON THE EXPRESS CONDITION THAT THE CONTENTS WILL NOT BE DISCLOSED OR USED WITHOUT WRITTEN CONSENT.

SUBMISSION OF THESE DRAWINGS OR DOCUMENTS DOES NOT CONSTITUTE PART PERFORMANCE OR ACCEPTANCE OF CONTRACT.

CONNECTION SIZES	
A	1 3/8" [35] DIA FIELD POWER SUPPLY HOLE
B	2 1/2" [64] DIA POWER SUPPLY KNOCKOUT
C	1 3/4" [51] DIA GAUGE ACCESS PLUG
D	7/8" [22] DIA FIELD CONTROL WIRING HOLE
E	3/4"-14 NPT CONDENSATE DRAIN
F	1/2"-14 NPT GAS CONNECTION 3/4"-14 NPT GAS CONNECTION
G	2" [51] DIA POWER SUPPLY KNOCK-OUT

THRU-THE-BASE CHART (FIELD INST)			
THESE HOLES REQUIRED FOR USE WITH ACCY KITS: CRBTMPWR002A01: GAS THRU CURB CRBTMPWR004A01: GAS THRU BASEPAN			
	THREADED CONDUIT SIZE	WIRE USE	REQ'D HOLE SIZES (MAX.)
W	1/2"	ACC.	7/8" [22.2]
X	1/2"	24V	7/8" [22.2]
Y	1 1/4" (002,004)	POWER	1 3/4" [44.4]
Z *	(004) 3/4" FPT	GAS	1 3/4" [44.4]

* (002) PROVIDES 3/4" FPT THRU CURB FLANGE & FITTING. HOLE SIZE: 2" [50.8]

THRU-THE-BASE CHART (FIOP)	
FOR "THRU-THE-BASEPAN" FACTORY OPTION, FITTINGS FOR ONLY X, Y, & Z ARE PROVIDED. **	
** FOR BELOW LISTED MODELS, A FIELD SUPPLIED 1/2" ADAPTER IS REQUIRED BETWEEN BASE PAN FITTING AND GAS VALVE: RGV-090, RGV-102	

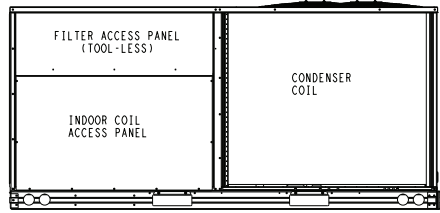

BACK

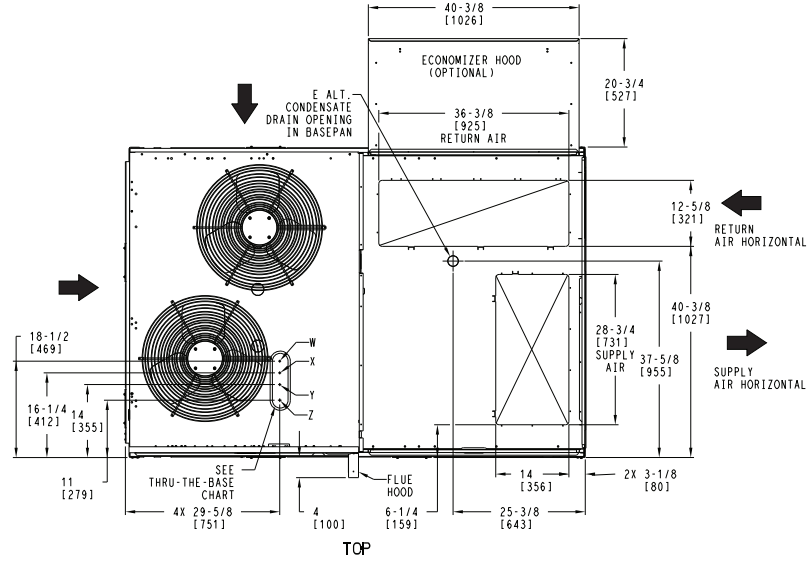

TOP

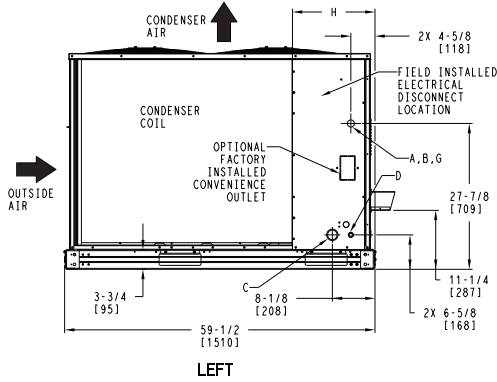

LEFT

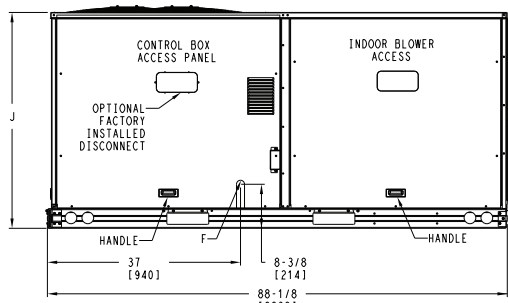

FRONT

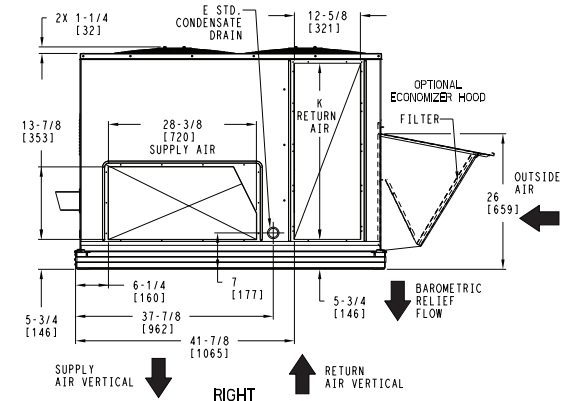

RIGHT

ITC CLASSIFICATION U.S. ECCN: NSR	SHEET 1 OF 3	DATE 06/01/21	SUPERCEDES -	RGV 090-120 SINGLE ZONE ELECTRICAL COOLING WITH GAS HEAT	48TM006407	REV A
--------------------------------------	-----------------	------------------	-----------------	--	------------	----------

RGV090-120 BASE UNIT DIMENSIONS (cont)

UNIT	OUTDOOR COIL TYPE	STD. UNIT WEIGHT ***		CORNER WEIGHT (A)		CORNER WEIGHT (B)		CORNER WEIGHT (C)		CORNER WEIGHT (D)		C.G.		
		LBS.	KG.	LBS.	KG.	LBS.	KG.	LBS.	KG.	LBS.	KG.	X	Y	Z
RGV-090	RTPF	787	357	181	82	150	68	207	94	249	113	40	34 1/2	19 3/8
RGV-102	RTPF	868	394	197	89	160	73	229	104	282	128	39 1/2	35	18 5/8
RGV-120	RTPF	878	398	213	97	175	80	221	100	268	121	39 7/8	33 1/4	18 1/2

RTPF - ROUND TUBE, PLATE FIN (COPPER/ALUM)



THIS DOCUMENT IS THE PROPERTY OF CARRIER CORPORATION AND IS DELIVERED UPON THE EXPRESS CONDITION THAT THE CONTENTS WILL NOT BE DISCLOSED OR USED WITHOUT WRITTEN CONSENT. SUBMISSION OF THESE DRAWINGS OR DOCUMENTS DOES NOT CONSTITUTE PART PERFORMANCE OR ACCEPTANCE OF CONTRACT.

*** STANDARD UNIT WEIGHT IS WITH LOW GAS HEAT AND WITHOUT PACKAGING. FOR OTHER OPTIONS AND ACCESSORIES, REFER TO THE PRODUCT DATA CATALOG.

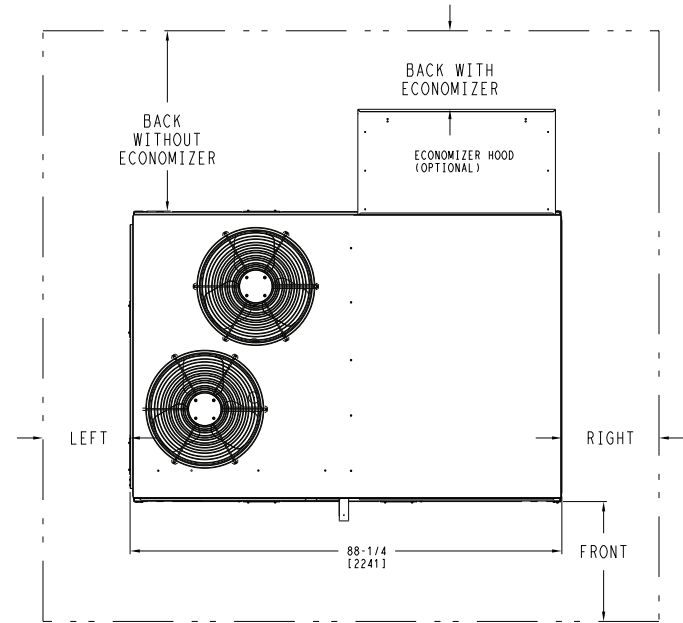
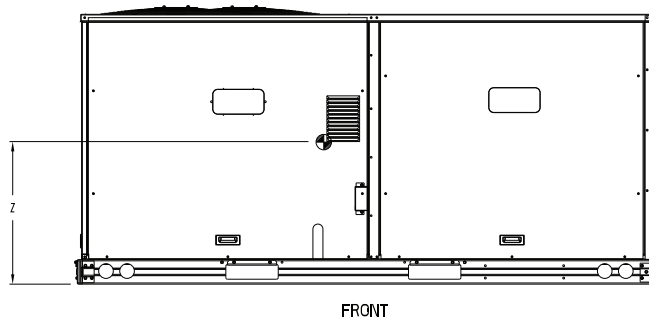
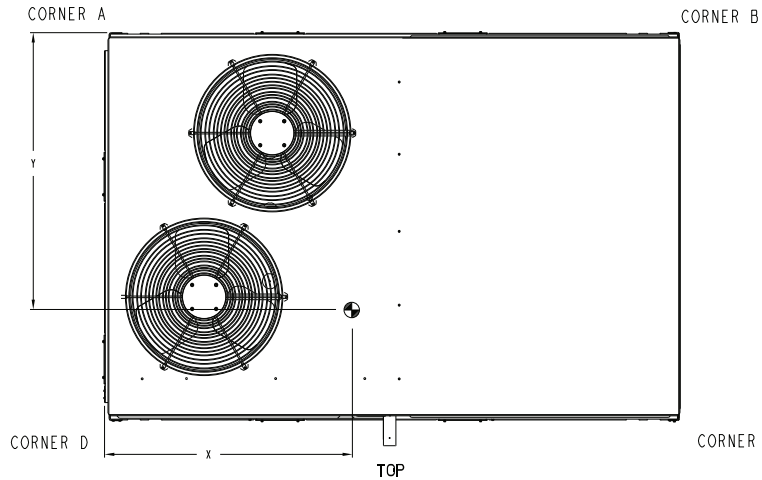

NOTE:

1. FOR ALL MINIMUM CLEARANCES LOCAL CODES OR JURISDICTIONS MAY PREVAIL.

SURFACE	CLEARANCE		OPERATING CLEARANCE
	SERVICE WITH: CONDUCTIVE BARRIER	SERVICE WITH: NONCONDUCTIVE BARRIER	
FRONT	48 [1219mm]	36 [914mm]	18 [457mm]
LEFT	48 [1219mm]	42 [1067mm]	18 [457mm]
BACK W/O ECON	48 [1219mm]	42 [1067mm]	18 [457mm]
BACK W/ECON	36 [914mm]	36 [914mm]	18 [457mm]
RIGHT	36 [914mm]	36 [914mm]	18 [457mm]
TOP	72 [1829mm]	72 [1829mm]	72 [1829mm]

ITC CLASSIFICATION U.S. ECCN:NSR	SHEET 2 OF 3	DATE 06/01/21	SUPERCEDES -	RGV 090-120 SINGLE ZONE ELECTRICAL COOLING WITH GAS HEAT	48TM006407	REV A
-------------------------------------	-----------------	------------------	-----------------	--	------------	----------

RGV090-120 BASE UNIT DIMENSIONS (cont)



THIS DOCUMENT IS THE PROPERTY OF CARRIER CORPORATION AND IS DELIVERED UPON THE EXPRESS CONDITION THAT THE CONTENTS WILL NOT BE DISCLOSED OR USED WITHOUT WRITTEN CONSENT.

SUBMISSION OF THESE DRAWINGS OR DOCUMENTS DOES NOT CONSTITUTE PART PERFORMANCE OR ACCEPTANCE OF CONTRACT.

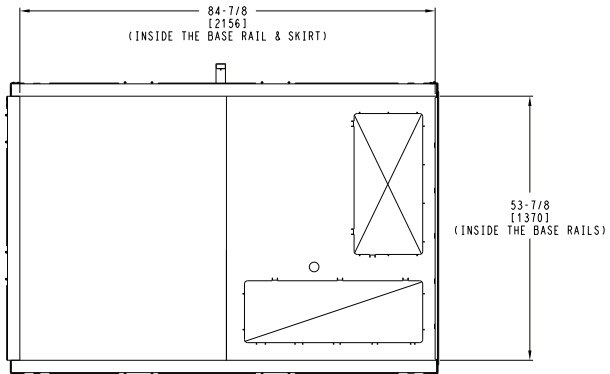
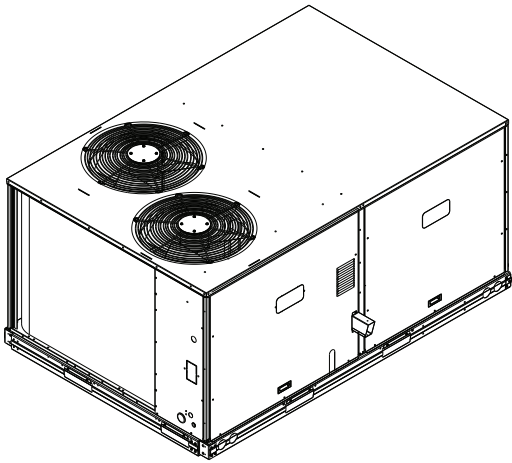

INSIDE BASERAIL DIMENSIONS
BOTTOM

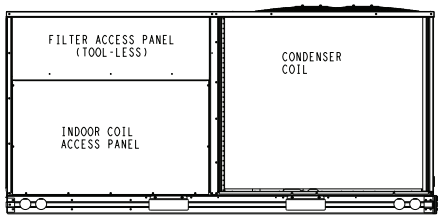
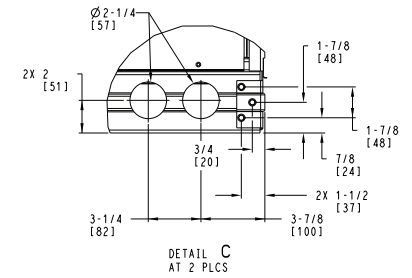
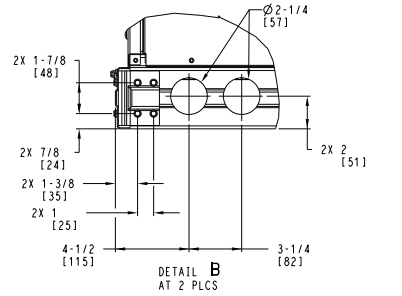

BACK

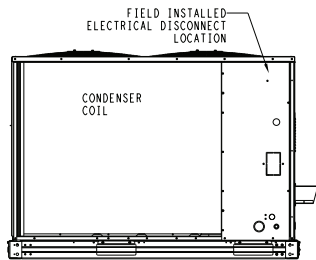

LEFT

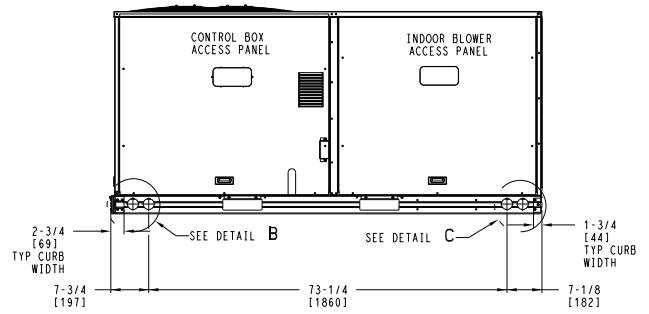

ITC CLASSIFICATION	SHEET	DATE	SUPERCEDES	RGV 090-120 SINGLE ZONE ELECTRICAL COOLING WITH GAS HEAT	48TM006407	REV
U.S. ECCN:NSR	3 OF 3	06/01/21	-			A

RGV150 BASE UNIT DIMENSIONS

- NOTES:
1. DIMENSIONS ARE IN INCHES, DIMENSIONS IN [] ARE IN MILLIMETERS.
 2. CENTER OF GRAVITY
 3. DIRECTION OF AIR FLOW
 4. ALL VIEW DRAWN USING 3RD ANGLE

UNIT	OUTDOOR COIL TYPE	H
RGV-150	RTPF	15 7/8 [403]

RTPF - ROUND TUBE, PLATE FIN (COPPER/ALUM)

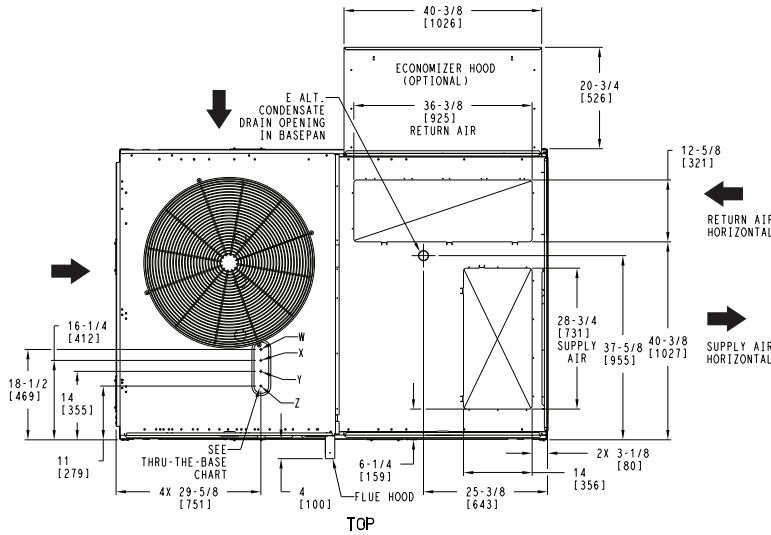
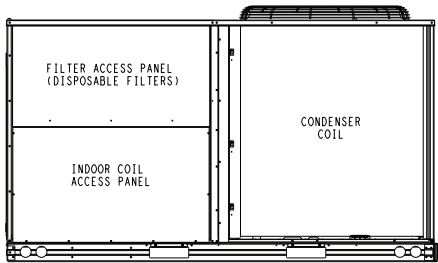

CONNECTION SIZES	
A	1 3/8" [35] DIA. FIELD POWER SUPPLY HOLE
B	2 1/2" [64] DIA. POWER SUPPLY KNOCKOUT
C	1 3/4" [51] DIA. GAUGE ACCESS PLUG
D	7/8" [22] DIA. FIELD CONTROL WIRING HOLE
E	3/4"-14 NPT CONDENSATE DRAIN
F	3/4"-14 NPT GAS CONNECTION
G	2" [51] DIA. POWER SUPPLY KNOCK-OUT

THRU-THE-BASE CHART THESE HOLES REQUIRED FOR USE CRBTMPWRO02A01, 004A01			
	THREADED CONDUIT SIZE	WIRE USE	REQ'D HOLE SIZES (MAX.)
W	1/2"	ACC.	7/8" [22.2]
X	1/2"	24V	7/8" [22.2]
Y	1 1/4" (002,004)	POWER	1 3/4" [44.4]
Z*	(004) 3/4" FPT	GAS	1 5/8" [41.3]

FOR "THRU-THE-BASEPAN" FACTORY OPTION, FITTINGS FOR ONLY X, Y, & Z ARE PROVIDED

* (002) PROVIDES 3/4" FPT THRU CURB FLANGE & FITTING.

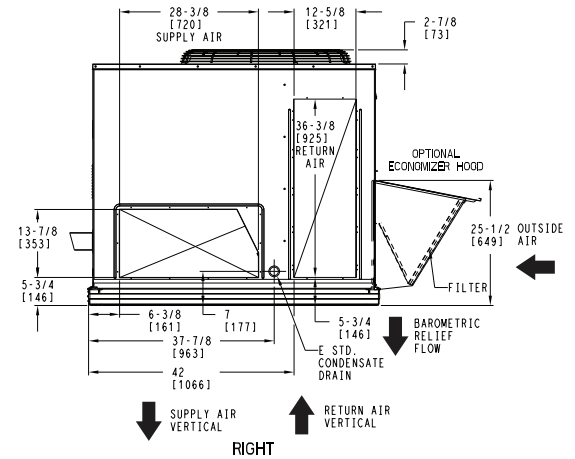
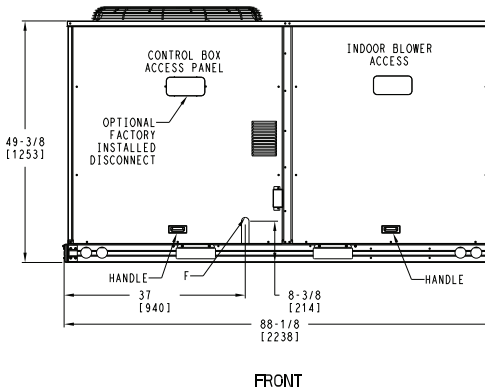
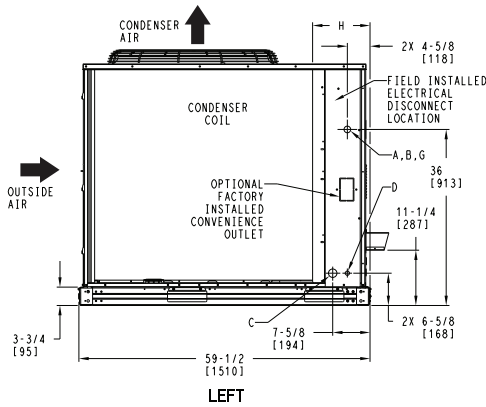

ITC CLASSIFICATION U.S. ECCN:NSR	SHEET 1 OF 3	DATE 06/01/21	SUPERCEDES -	RGV-150 SINGLE ZONE ELECTRICAL COOLING WITH GAS HEAT	48TM006409	REV -
-------------------------------------	-----------------	------------------	-----------------	--	------------	----------

IGP THIS DOCUMENT IS THE PROPERTY OF CARRIER CORPORATION AND IS DELIVERED UPON THE EXPRESS CONDITION THAT THE CONTENTS WILL NOT BE DISCLOSED OR USED WITHOUT WRITTEN CONSENT.

SUBMISSION OF THESE DRAWINGS OR DOCUMENTS DOES NOT CONSTITUTE PART PERFORMANCE OR ACCEPTANCE OF CONTRACT.

RGV150 BASE UNIT DIMENSIONS (cont)

UNIT	OUTDOOR COIL TYPE	STD. UNIT WEIGHT***		CORNER WEIGHT (A)		CORNER WEIGHT (B)		CORNER WEIGHT (C)		CORNER WEIGHT (D)		C.G.					
		LBS.	KG.	LBS.	KG.	LBS.	KG.	LBS.	KG.	LBS.	KG.	X	Y	Z			
RGV-150	RTPF	1041	472	243	110	195	88	269	122	335	152	39 1/4	[997]	34 1/2	[876]	21 7/8	[556]

*** STANDARD UNIT WEIGHT IS WITH LOW GAS HEAT AND WITHOUT PACKAGING. FOR OTHER OPTIONS AND ACCESSORIES, REFER TO THE PRODUCT DATA CATALOG.



THIS DOCUMENT IS THE PROPERTY OF CARRIER CORPORATION AND IS DELIVERED UPON THE EXPRESS CONDITION THAT THE CONTENTS WILL NOT BE DISCLOSED OR USED WITHOUT WRITTEN CONSENT.

SUBMISSION OF THESE DRAWINGS OR DOCUMENTS DOES NOT CONSTITUTE PART PERFORMANCE OR ACCEPTANCE OF CONTRACT.

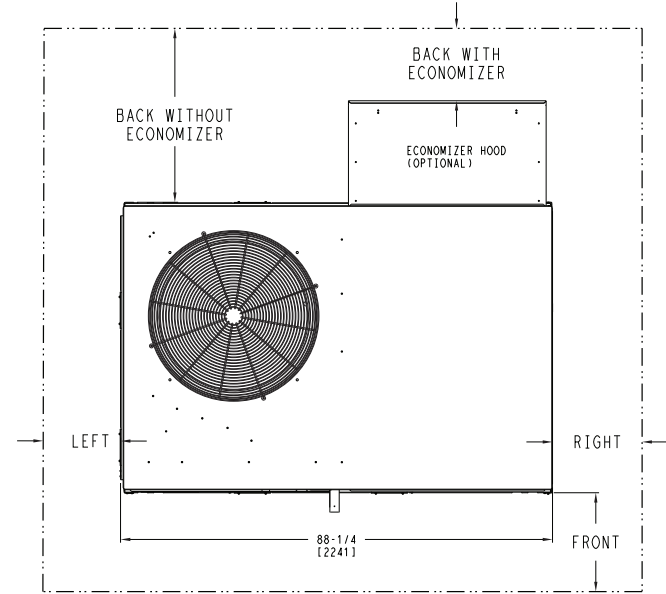
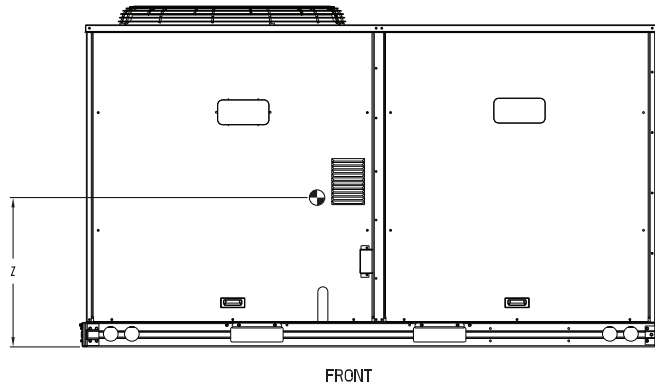
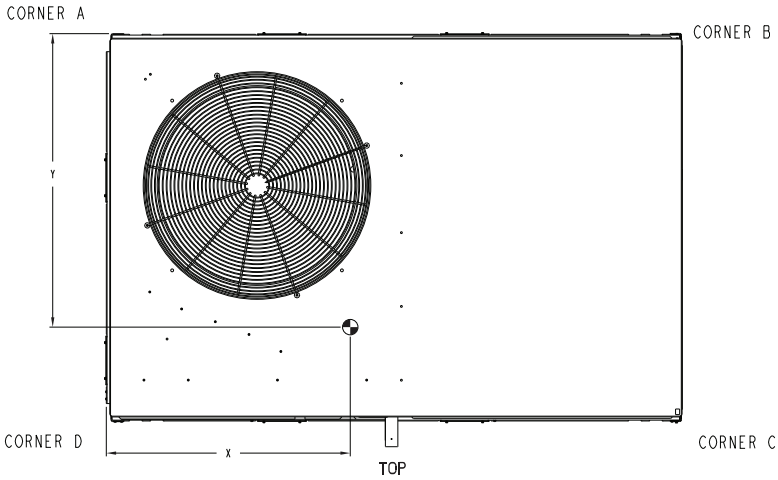

NOTE:

1. FOR ALL MINIMUM CLEARANCES LOCAL CODES OR JURISDICTIONS MAY PREVAIL.

SURFACE	CLEARANCE		OPERATING CLEARANCE
	SERVICE WITH: CONDUCTIVE BARRIER	SERVICE WITH: NONCONDUCTIVE BARRIER	
FRONT	48 [1219mm]	36 [914mm]	18 [457mm]
LEFT	48 [1219mm]	42 [1067mm]	18 [457mm]
BACK W/O ECON	48 [1219mm]	42 [1067mm]	18 [457mm]
BACK W/ECON	36 [914mm]	36 [914mm]	18 [457mm]
RIGHT	36 [914mm]	36 [914mm]	18 [457mm]
TOP	72 [1829mm]	72 [1829mm]	72 [1829mm]

ITC CLASSIFICATION U.S. ECCN:NSR	SHEET 2 OF 3	DATE 06/01/21	SUPERCEDES -	RGV-150 SINGLE ZONE ELECTRICAL COOLING WITH GAS HEAT	48TM006409	REV -
-------------------------------------	-----------------	------------------	-----------------	--	------------	----------

RGV150 BASE UNIT DIMENSIONS (cont)



THIS DOCUMENT IS THE PROPERTY OF CARRIER CORPORATION AND IS DELIVERED UPON THE EXPRESS CONDITION THAT THE CONTENTS WILL NOT BE DISCLOSED OR USED WITHOUT WRITTEN CONSENT.

SUBMISSION OF THESE DRAWINGS OR DOCUMENTS DOES NOT CONSTITUTE PART PERFORMANCE OR ACCEPTANCE OF CONTRACT.

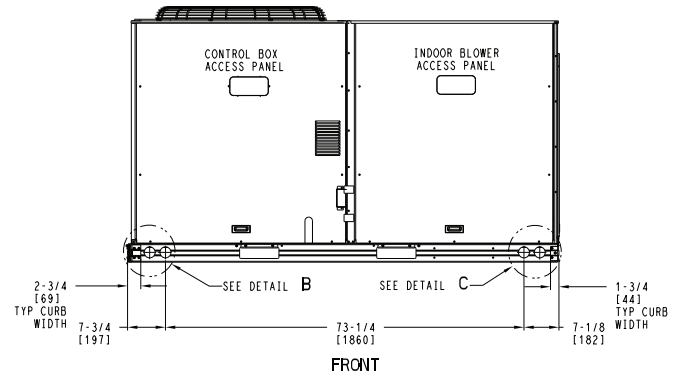
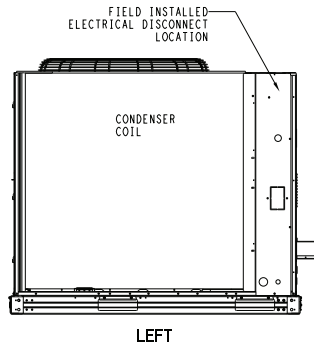
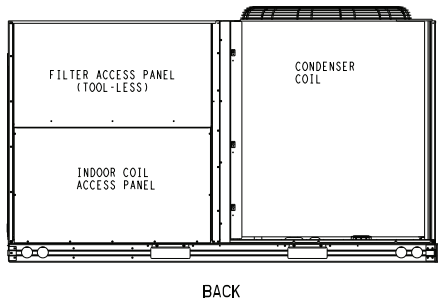
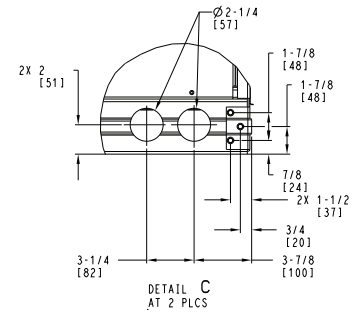
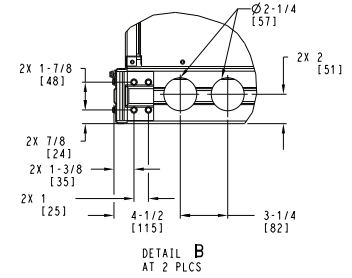
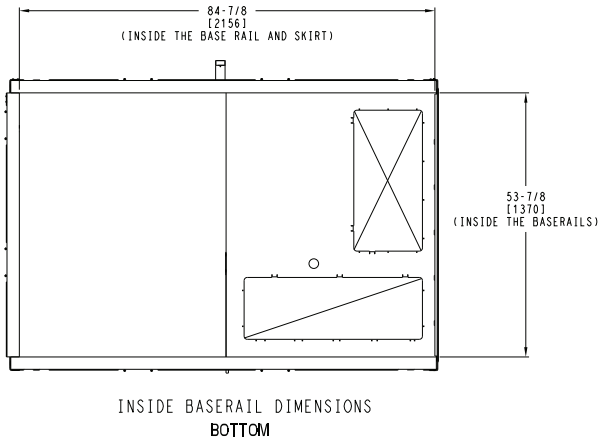
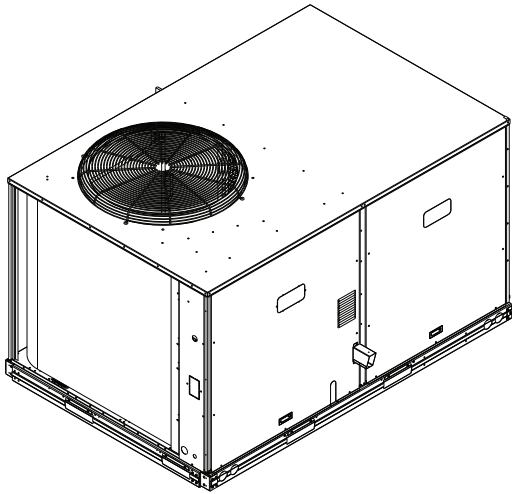

ITC CLASSIFICATION U.S. ECCN:NSR	SHEET 3 OF 3	DATE 06/01/21	SUPERCEDES -	RGV-150 SINGLE ZONE ELECTRICAL COOLING WITH GAS HEAT	48TM006409	REV -
-------------------------------------	-----------------	------------------	-----------------	---	------------	----------

RGV180 BASE UNIT DIMENSIONS

- NOTES:
1. DIMENSIONS ARE IN INCHES, DIMENSIONS IN () ARE IN MILLIMETERS.
 2. CENTER OF GRAVITY
 3. DIRECTION OF AIR FLOW



THIS DOCUMENT IS THE PROPERTY OF CARRIER CORPORATION AND IS DELIVERED UPON THE EXPRESS CONDITION THAT THE CONTENTS WILL NOT BE DISCLOSED OR USED WITHOUT WRITTEN CONSENT.

SUBMISSION OF THESE DRAWINGS OR DOCUMENTS DOES NOT CONSTITUTE PART PERFORMANCE OR ACCEPTANCE OF CONTRACT.

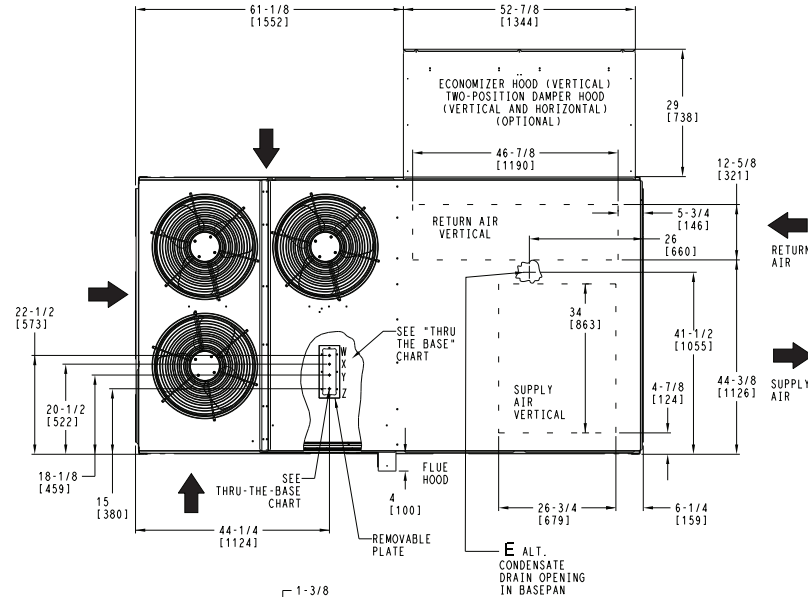
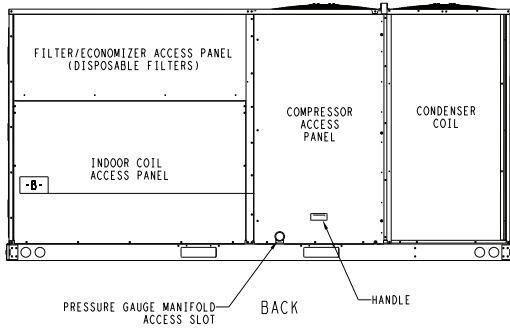

CONNECTION SIZES	
B	2 1/2" [64] DIA POWER SUPPLY HOLE
D	7/8" [22] DIA FIELD CONTROL WIRING HOLE
E	3/4"-14 NPT CONDENSATE DRAIN
F	7/8" [22] DIA FIELD CONVENIENCE OUTLET HOLE
G	3/4"-14 NPT GAS CONNECTION

THRU-THE-BASE CHART THESE HOLES REQUIRED FOR USE CRBTPMWR005A00, 006A00, 007A00				
ACCESSORY NO.	THREADED CONDUIT SIZE	WIRE USE	REQ'D HOLE SIZES (MAX.)	
005	W	1/2"	ACC.	7/8" [22.2]
	X	1/2"	24V	7/8" [22.2]
	Y	1 1/4"	POWER	1 1/2" [38.1]
006	Z	3/4" PIPE	GAS	1 3/4" [44.5]
	W	1/2"	ACC.	7/8" [22.2]
	X	1/2"	24V	7/8" [22.2]
007	Y	1 1/2"	POWER	2" [50.8]
	Z	3/4" PIPE	GAS	1 3/4" [44.5]
	W	1/2"	ACC.	7/8" [22.2]
	X	1/2"	24V	7/8" [22.2]
	Y	2"	POWER	2 1/2" [63.5]
	Z	3/4" PIPE	GAS	1 3/4" [44.5]

FOR "THRU-THE-BASEPAN" FACTORY OPTION, FITTINGS FOR X & Y ARE PROVIDED AS SPECIFIED ON "006".

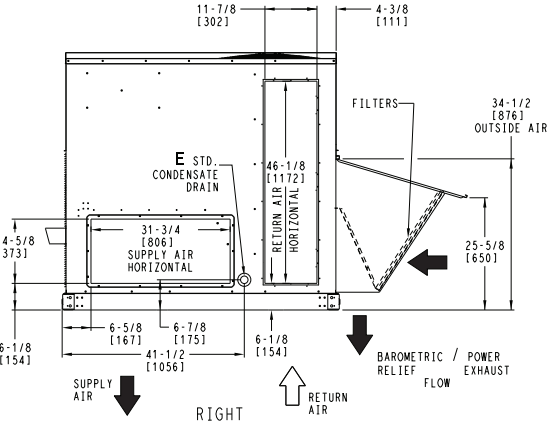
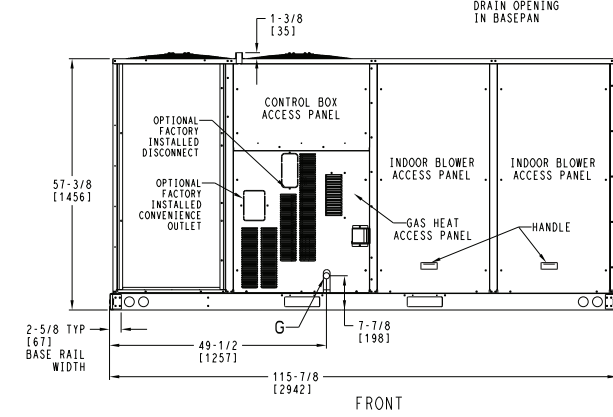
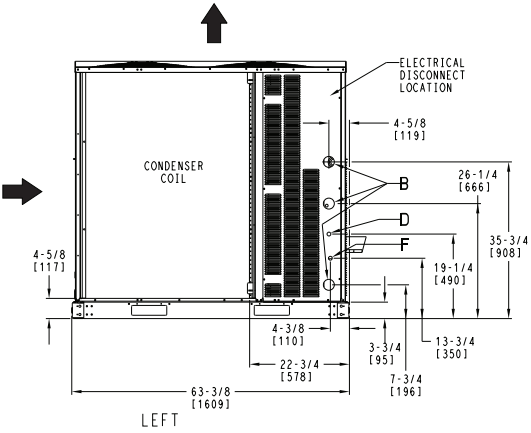

ITC CLASSIFICATION	SHEET	DATE	SUPERCEDES	RGV 180 SINGLE ZONE ELECTRICAL COOLING WITH GAS HEAT	50TM002140	REV
U.S. ECCN:NSR	1 OF 2	06/28/22	06/17/21			A

RGV180 BASE UNIT DIMENSIONS (cont)

UNIT	STD UNIT WEIGHT		CORNER WEIGHT (A)		CORNER WEIGHT (B)		CORNER WEIGHT (C)		CORNER WEIGHT (D)		C.G.		
	LBS.	KG.	LBS.	KG.	LBS.	KG.	LBS.	KG.	LBS.	KG.	X	Y	Z
RGV-180	1408	639	373	169	341	155	332	150	362	164	55 3/8 [1407]	31 1/4 [794]	21 1/8 [537]

STANDARD UNIT WEIGHT IS WITH LOW HEAT & WITHOUT PACKAGING.
FOR OPTIONS & ACCESSORIES, REFER TO THE PRODUCT DATA CATALOG.

IGP THIS DOCUMENT IS THE PROPERTY OF CARRIER CORPORATION AND IS DELIVERED UPON THE EXPRESS CONDITION THAT THE CONTENTS WILL NOT BE DISCLOSED OR USED WITHOUT WRITTEN CONSENT. SUBMISSION OF THESE DRAWINGS OR DOCUMENTS DOES NOT CONSTITUTE PART PERFORMANCE OR ACCEPTANCE OF CONTRACT.

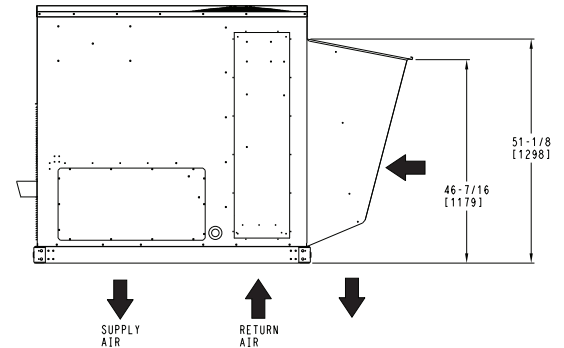
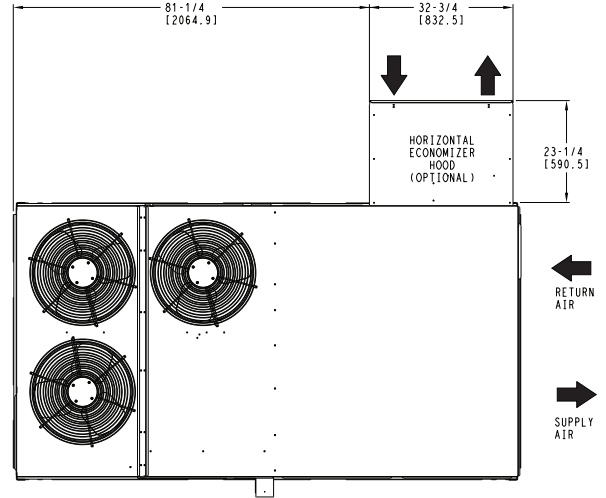
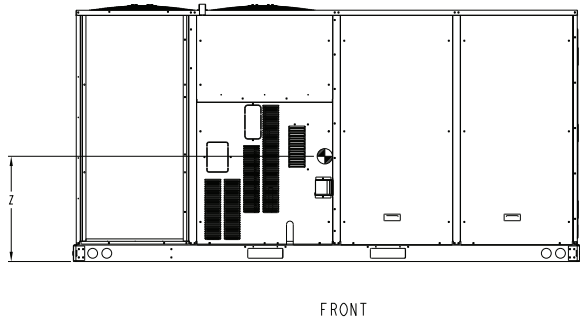
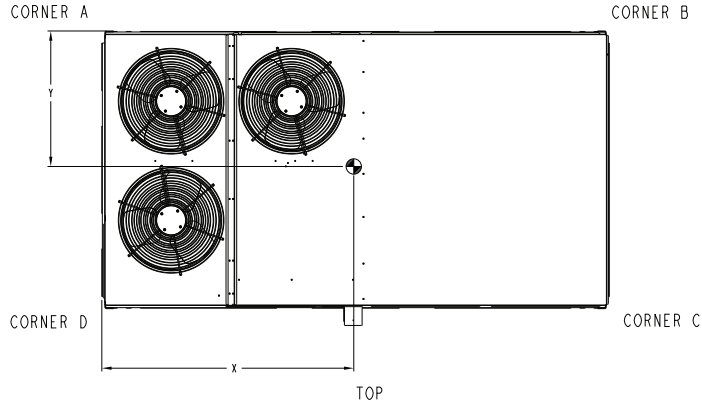

ITC CLASSIFICATION U.S. ECCN:NSR	SHEET 2 OF 2	DATE 06/28/22	SUPERCEDES 06/17/21	RGV 180 SINGLE ZONE ELECTRICAL COOLING WITH GAS HEAT	50TM002140	REV A
-------------------------------------	-----------------	------------------	------------------------	---	------------	----------

Base unit dimensions (cont)

RGV180 BASE UNIT DIMENSIONS — CLEARANCE

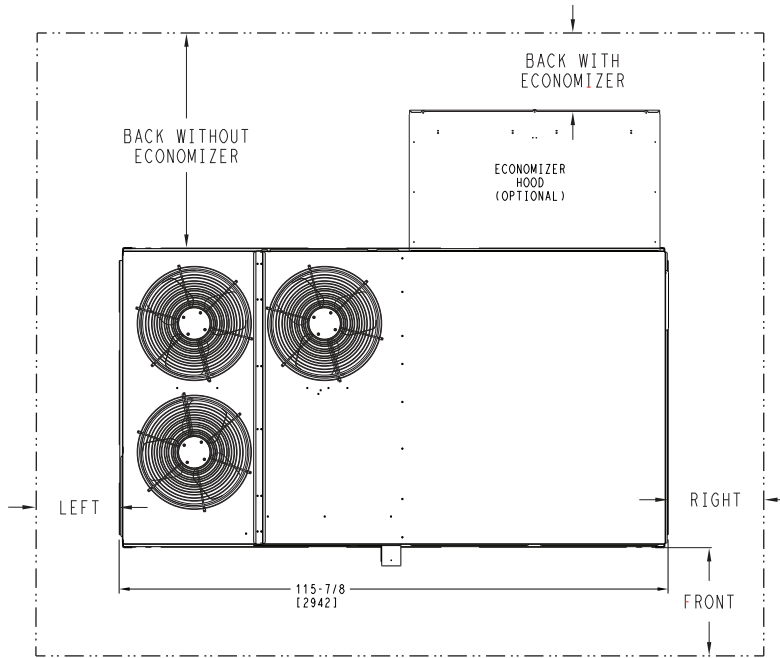

CLEARANCE^{a, b}

SURFACE	Service with Conductive Barrier	Service with Non-conductive Barrier	Operating Clearance
FRONT	48 in. (1219 mm)	36 in. (914 mm)	18 in. (457 mm)
LEFT	48 in. (1219 mm)	42 in. (1067 mm)	18 in. (457 mm)
BACK W/O ECONOMIZER	48 in. (1219 mm)	42 in. (1067 mm)	18 in. (457 mm)
BACK W/ ECONOMIZER	36 in. (914 mm)	36 in. (914 mm)	18 in. (457 mm)
RIGHT	36 in. (914 mm)	36 in. (914 mm)	18 in. (457 mm)
TOP	72 in. (1829 mm)	72 in. (1829 mm)	72 in. (1829 mm)

NOTE(S):

- a. For all minimum clearances local codes or jurisdictions may prevail.
- b. See page 18 for RGV090-120 clearances. See page 21 for RGV150 clearances.

RAV090-120 BASE UNIT DIMENSIONS

- NOTES:
1. DIMENSIONS ARE IN INCHES, DIMENSIONS IN [] ARE IN MILLIMETERS.
 2. CENTER OF GRAVITY
 3. DIRECTION OF AIR FLOW
 4. ALL VIEW DRAWN USING 3RD ANGLE

UNIT	OUTDOOR COIL TYPE	J	K	H
RAV-090	RTPF	41 1/4 [1048]	33 3/4 [857]	15 7/8 [403]
RAV-102	RTPF	49 3/8 [1253]	36 3/8 [925]	15 7/8 [403]
RAV-120	RTPF	49 3/8 [1253]	36 3/8 [925]	15 7/8 [403]

RTPF - ROUND TUBE, PLATE FIN (COPPER/ALUM)



THIS DOCUMENT IS THE PROPERTY OF CARRIER CORPORATION AND IS DELIVERED UPON THE EXPRESS CONDITION THAT THE CONTENTS WILL NOT BE DISCLOSED WITHOUT WRITTEN CONSENT.

SUBMISSION OF THESE DRAWINGS OR DOCUMENTS DOES NOT CONSTITUTE PART PERFORMANCE OR ACCEPTANCE OF CONTRACT.

CONNECTION SIZES		
A	1 3/8" [35]	FIELD POWER SUPPLY HOLE
B	2 1/2" [64]	POWER SUPPLY KNOCKOUT
C	1 3/4" [51]	GAUGE ACCESS PLUG
D	7/8" [22]	FIELD CONTROL WIRING HOLE
E	3/4"-14 NPT	CONDENSATE DRAIN
G	2" [51]	DIA POWER SUPPLY KNOCK-OUT

THRU-THE-BASE CHART (FIELD INST)
THESE HOLES REQUIRED FOR USE WITH ACCY KITS: CRBTMPWRO02A01

	THREADED CONDUIT SIZE	WIRE USE	REQ'D HOLE SIZES (MAX.)
W	1/2"	ACC.	7/8" [22.2]
X	1/2"	24V	7/8" [22.2]
Y	1 1/4" (002)	POWER	1 3/4" [44.4]

THRU-THE-BASE CHART (FIOP)
FOR "THRU-THE-BASEPAN" FACTORY OPTION, FITTINGS FOR ONLY X & Y ARE PROVIDED: (1) 1/2" & (1) 1 1/4" ELECTRICAL FITTINGS.

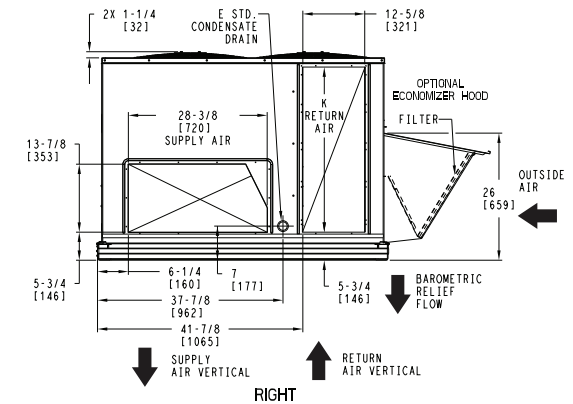
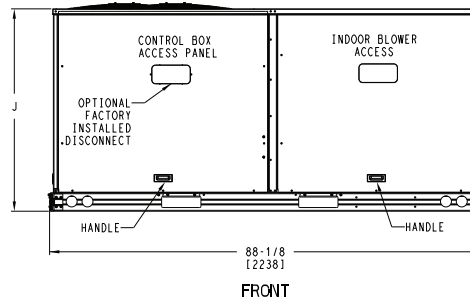
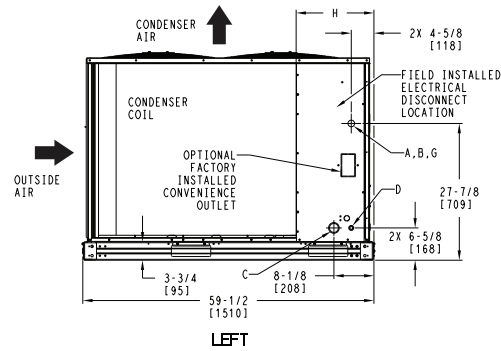
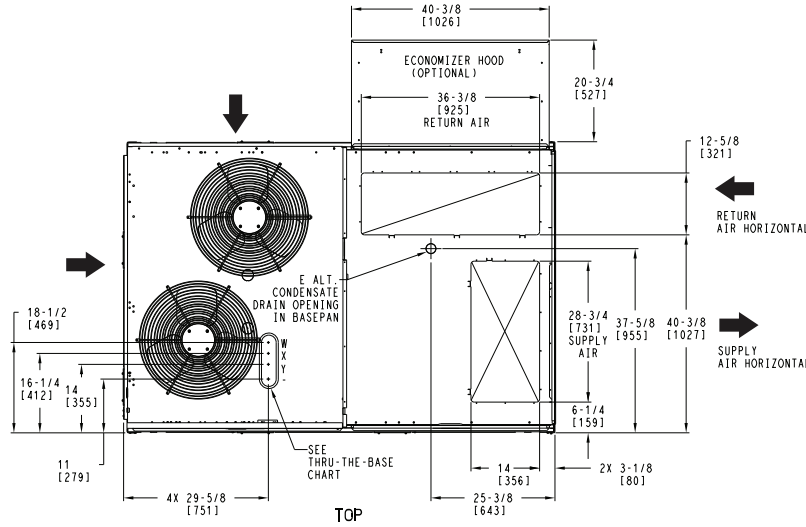
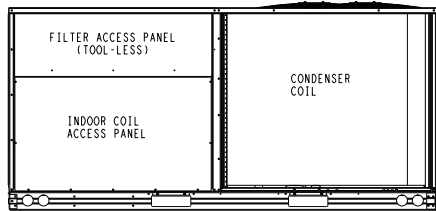

ITC CLASSIFICATION	SHEET	DATE	SUPERCEDES	RAV 090-120 SINGLE ZONE ELECTRICAL COOLING WITH ELECTRIC HEAT	48TM006408	REV
U.S. ECCN:NSR	1 OF 3	06/01/21	-			-

RAV090-120 BASE UNIT DIMENSIONS (cont)

UNIT	OUTDOOR COIL TYPE	STD. UNIT WEIGHT ***		CORNER WEIGHT (A)		CORNER WEIGHT (B)		CORNER WEIGHT (C)		CORNER WEIGHT (D)		C. G.		
		LBS.	KG.	LBS.	KG.	LBS.	KG.	LBS.	KG.	LBS.	KG.	X	Y	Z
RAV-090	RTPF	743	337	170	77	142	64	196	89	235	107	40	34 1/2 [838]	20 [508]
RAV-102	RTPF	805	365	196	89	251	114	201	91	157	71	49 1/2 [1257]	26 1/2 [673]	19 1/8 [486]
RAV-120	RTPF	815	370	198	90	254	115	204	92	159	72	49 1/2 [1257]	26 1/2 [673]	19 1/8 [486]

*** STANDARD UNIT WEIGHT IS WITHOUT ELECTRIC HEAT AND WITHOUT PACKAGING. FOR OTHER OPTIONS AND ACCESSORIES, REFER TO THE PRODUCT DATA CATALOG.



THIS DOCUMENT IS THE PROPERTY OF CARRIER CORPORATION AND IS DELIVERED UPON THE EXPRESS CONDITION THAT THE CONTENTS WILL NOT BE DISCLOSED WITHOUT WRITTEN CONSENT.

SUBMISSION OF THESE DRAWINGS OR DOCUMENTS DOES NOT CONSTITUTE PART PERFORMANCE OR ACCEPTANCE OF CONTRACT.

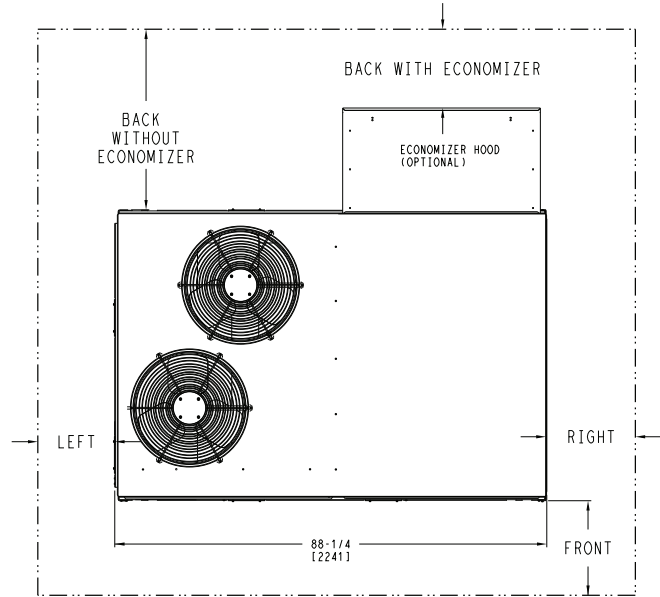
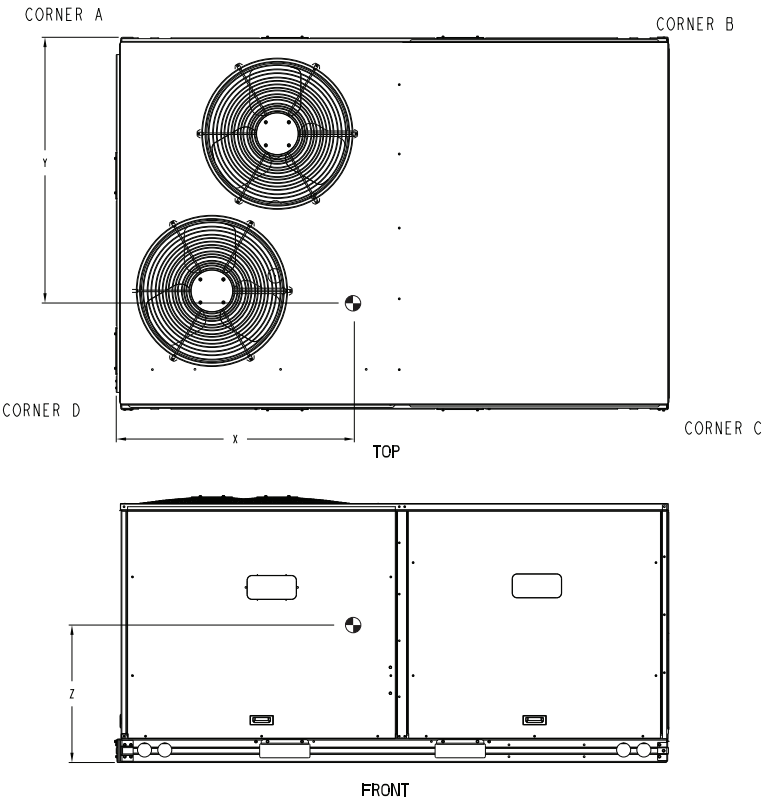

NOTE:

1. FOR ALL MINIMUM CLEARANCES LOCAL CODES OR JURISDICTIONS MAY PREVAIL.

SURFACE	CLEARANCE		OPERATING CLEARANCE
	SERVICE WITH CONDUCTIVE BARRIER	SERVICE WITH NONCONDUCTIVE BARRIER	
FRONT	48 [1219mm]	36 [914mm]	18 [457mm]
LEFT	48 [1219mm]	42 [1067mm]	18 [457mm]
BACK W/O ECON	48 [1219mm]	42 [1067mm]	18 [457mm]
BACK W/ECON	36 [914mm]	36 [914mm]	18 [457mm]
RIGHT	36 [914mm]	36 [914mm]	18 [457mm]
TOP	72 [1829mm]	72 [1829mm]	72 [1829mm]

ITC CLASSIFICATION U.S. ECCN:NSR	SHEET 2 OF 3	DATE 06/01/21	SUPERCEDES -	RAV 090-120 SINGLE ZONE ELECTRICAL COOLING WITH ELECTRIC HEAT	48TM006408	REV -
-------------------------------------	-----------------	------------------	-----------------	---	------------	----------

RAV090-120 BASE UNIT DIMENSIONS (cont)



THIS DOCUMENT IS THE PROPERTY OF CARRIER CORPORATION AND IS DELIVERED UPON THE EXPRESS CONDITION THAT THE CONTENTS WILL NOT BE DISCLOSED WITHOUT WRITTEN CONSENT.

SUBMISSION OF THESE DRAWINGS OR DOCUMENTS DOES NOT CONSTITUTE PART PERFORMANCE OR ACCEPTANCE OF CONTRACT.

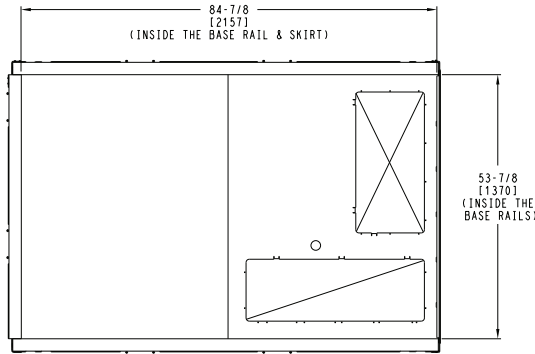
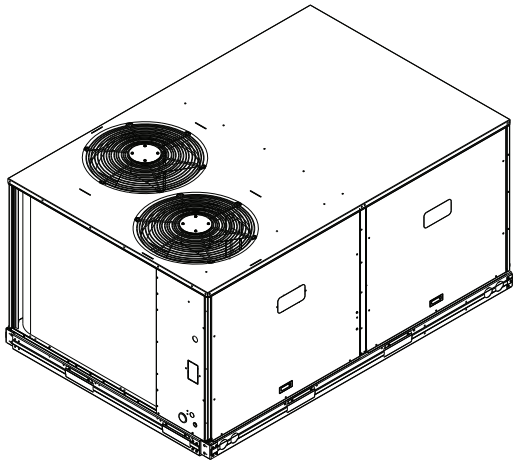

INSIDE BASERAIL DIMENSIONS
BOTTOM

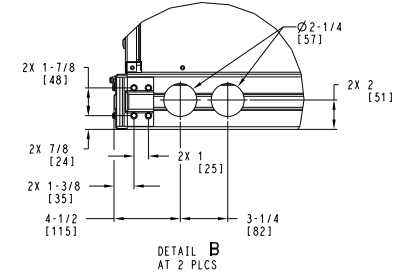

DETAIL B
AT 2 PLCS

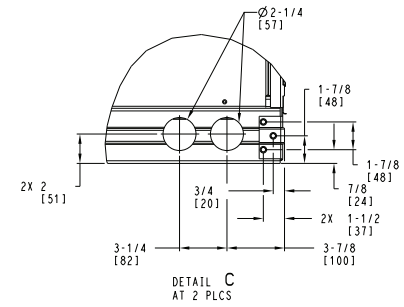

DETAIL C
AT 2 PLCS

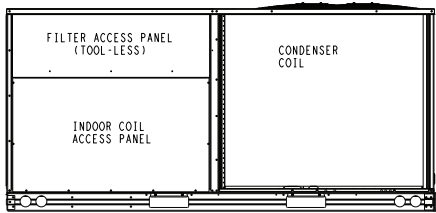

BACK

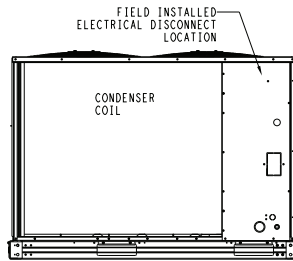

LEFT

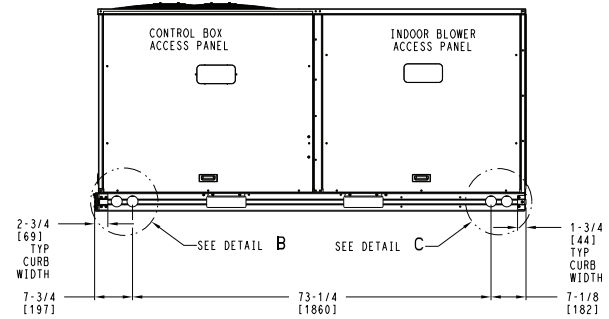

FRONT

ITC CLASSIFICATION	SHEET	DATE	SUPERCEDES	RAV 090-120 SINGLE ZONE ELECTRICAL COOLING WITH ELECTRIC HEAT	48TM006408	REV
U.S. ECCN:NSR	3 OF 3	06/01/21	-			-

RAV150 BASE UNIT DIMENSIONS

- NOTES:
1. DIMENSIONS ARE IN INCHES, DIMENSIONS IN [] ARE IN MILLIMETERS.
 2. CENTER OF GRAVITY
 3. DIRECTION OF AIR FLOW
 4. ALL VIEW DRAWN USING 3RD ANGLE

UNIT	OUTDOOR COIL TYPE	H
RAV-150	RTPF	15 7/8 [403]
RTPF - ROUND TUBE, PLATE FIN (COPPER/ALUM)		

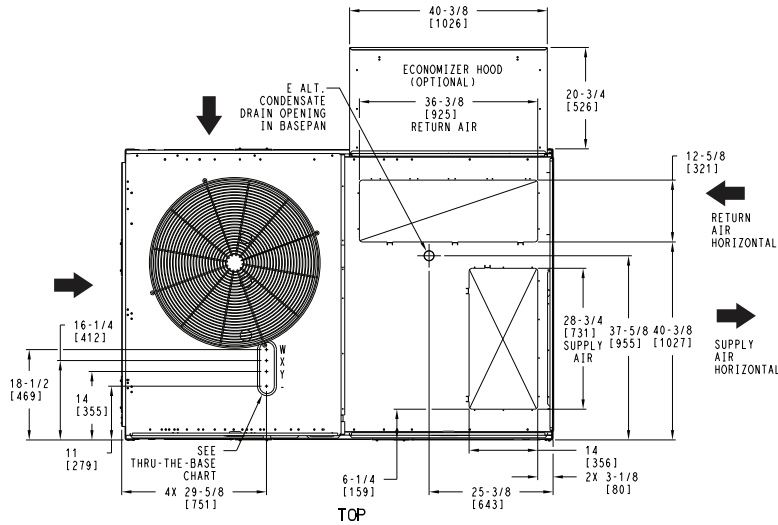
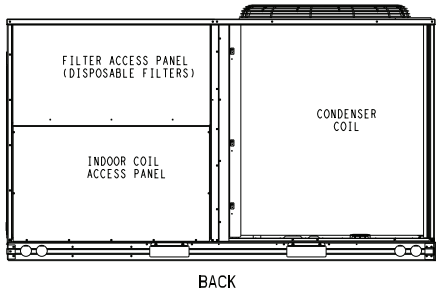

CONNECTION SIZES		
A	1 3/8" [35]	FIELD POWER SUPPLY HOLE
B	2 1/2" [64]	POWER SUPPLY KNOCKOUT
C	1 3/4" [51]	DIA GAUGE ACCESS PLUG
D	7/8" [22]	DIA FIELD CONTROL WIRING HOLE
E	3/4"-14 NPT	CONDENSATE DRAIN
G	2" [51]	DIA POWER SUPPLY KNOCK-OUT

THRU-THE-BASE CHART THESE HOLES REQUIRED FOR USE CRBTMPW002A01			
	THREADED CONDUIT SIZE	WIRE USE	REQ'D HOLE SIZES (MAX.)
W	1/2"	ACC.	7/8" [22.2]
X	1/2"	24V	7/8" [22.2]
Y	1 1/4" (002)	POWER	1 3/4" [44.4]

FOR "THRU-THE-BASEPAN" FACTORY OPTION, FITTINGS FOR ONLY X & Y ARE PROVIDED

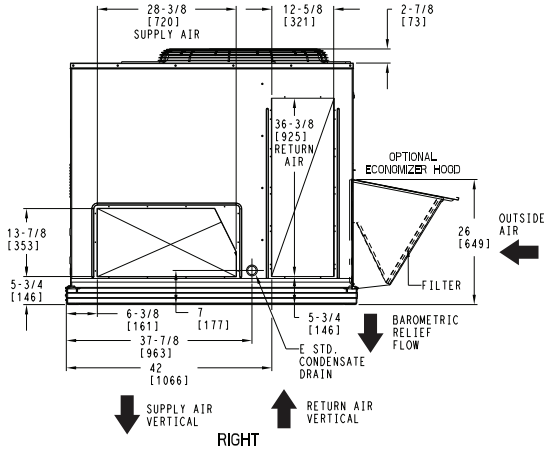
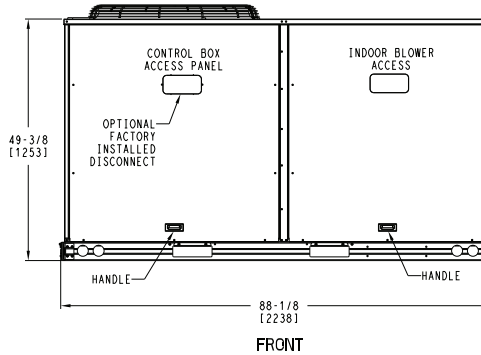
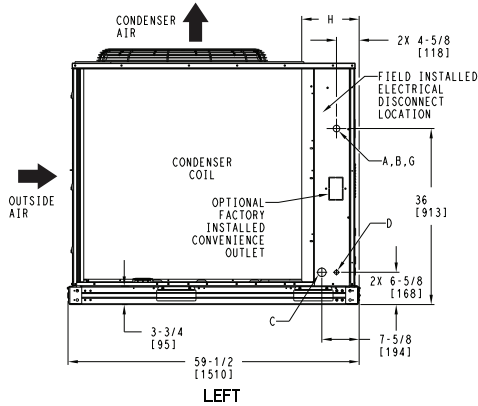

ITC CLASSIFICATION	SHEET	DATE	SUPERCEDES	RAV-150 SINGLE ZONE ELECTRICAL COOLING WITH ELECTRIC HEAT	48TM006410	REV
U.S. ECCN:NSR	1 OF 3	06/01/21	-			-

RAV150 BASE UNIT DIMENSIONS (cont)

UNIT	OUTDOOR COIL TYPE	STD. UNIT WEIGHT***		CORNER WEIGHT (A)		CORNER WEIGHT (B)		CORNER WEIGHT (C)		CORNER WEIGHT (D)		C.G.				
		LBS.	KG.	LBS.	KG.	LBS.	KG.	LBS.	KG.	LBS.	KG.	X	Y	Z		
RAV-150	RTPF	978	444	234	106	300	136	249	113	195	88	49	1/2 [1257]	27 [686]	20	1/2 [521]

*** STANDARD UNIT WEIGHT IS WITHOUT ELECTRIC HEAT AND WITHOUT PACKAGING. FOR OTHER OPTIONS AND ACCESSORIES, REFER TO THE PRODUCT DATA CATALOG.



THIS DOCUMENT IS THE PROPERTY OF CARRIER CORPORATION AND IS DELIVERED UPON THE EXPRESS CONDITION THAT THE CONTENTS WILL NOT BE DISCLOSED WITHOUT WRITTEN CONSENT.

SUBMISSION OF THESE DRAWINGS OR DOCUMENTS DOES NOT CONSTITUTE PART PERFORMANCE OR ACCEPTANCE OF CONTRACT.

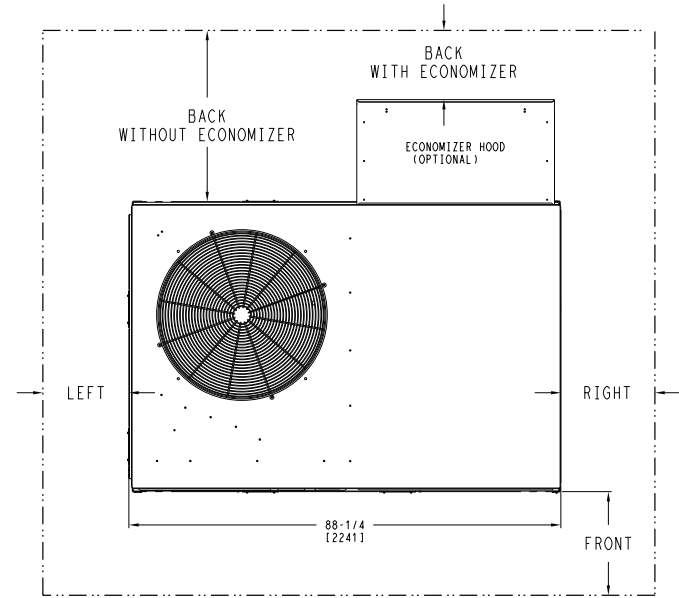
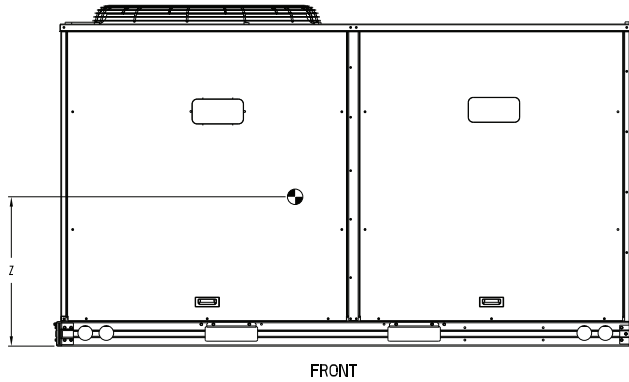
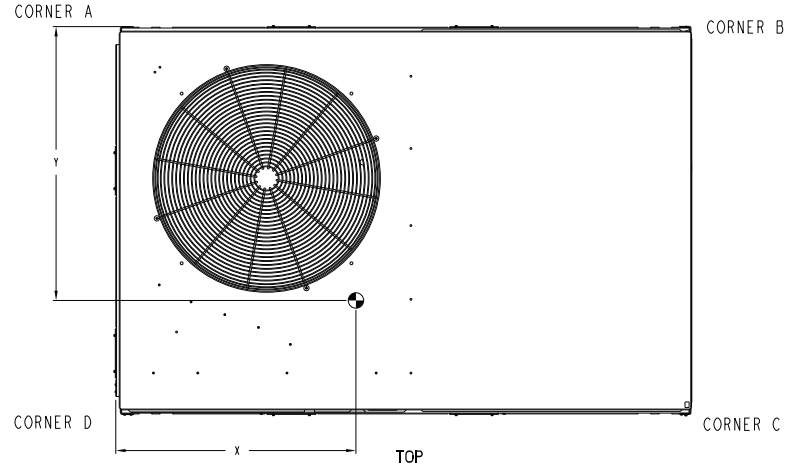

NOTE:

1. FOR ALL MINIMUM CLEARANCES LOCAL CODES OR JURISDICTIONS MAY PREVAIL.

SURFACE	CLEARANCE		OPERATING CLEARANCE
	SERVICE WITH: CONDUCTIVE BARRIER	SERVICE WITH: NONCONDUCTIVE BARRIER	
FRONT	48 [1219mm]	36 [914mm]	18 [457mm]
LEFT	48 [1219mm]	42 [1067mm]	18 [457mm]
BACK W/O ECON	48 [1219mm]	42 [1067mm]	18 [457mm]
BACK W/ECON	36 [914mm]	36 [914mm]	18 [457mm]
RIGHT	36 [914mm]	36 [914mm]	18 [457mm]
TOP	72 [1829mm]	72 [1829mm]	72 [1829mm]

ITC CLASSIFICATION U.S. ECCN:NSR	SHEET 2 OF 3	DATE 06/01/21	SUPERCEDES -	RAV-150 SINGLE ZONE ELECTRICAL COOLING WITH ELECTRIC HEAT	48TM006410	REV -
-------------------------------------	-----------------	------------------	-----------------	---	------------	----------

RAV150 BASE UNIT DIMENSIONS (cont)



THIS DOCUMENT IS THE PROPERTY OF CARRIER CORPORATION AND IS DELIVERED UPON THE EXPRESS CONDITION THAT THE CONTENTS WILL NOT BE DISCLOSED WITHOUT WRITTEN CONSENT.

SUBMISSION OF THESE DRAWINGS OR DOCUMENTS DOES NOT CONSTITUTE PART PERFORMANCE OR ACCEPTANCE OF CONTRACT.

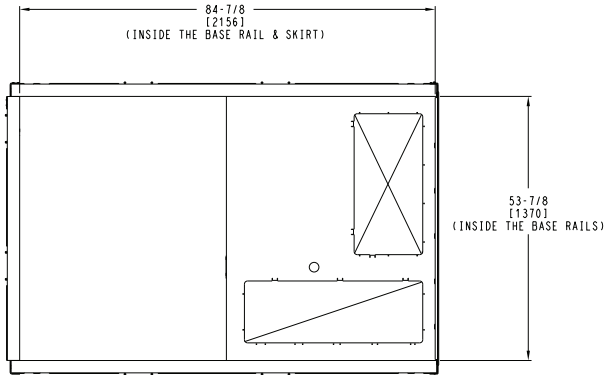
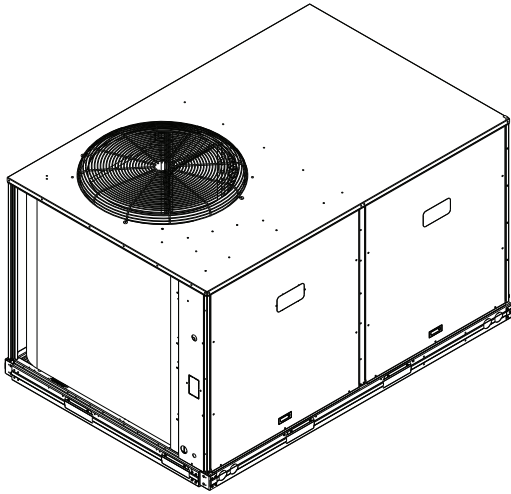

INSIDE BASERAIL DIMENSIONS
BOTTOM

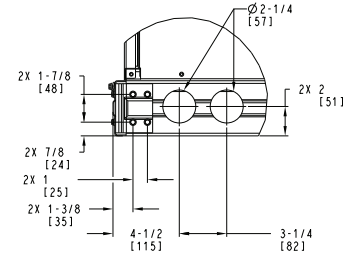

DETAIL B
TYP 2 PLCS

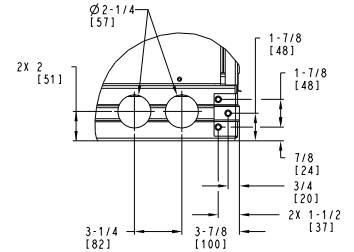

DETAIL C
TYP 2 PLCS

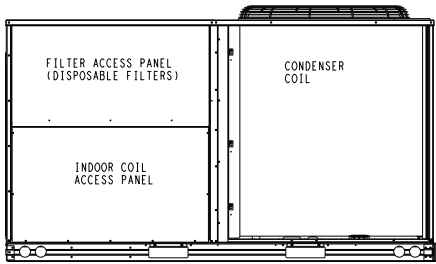

BACK

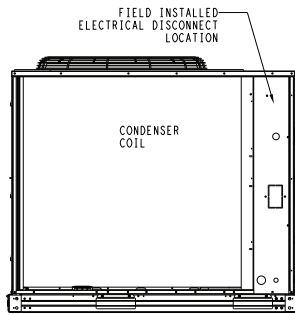

LEFT

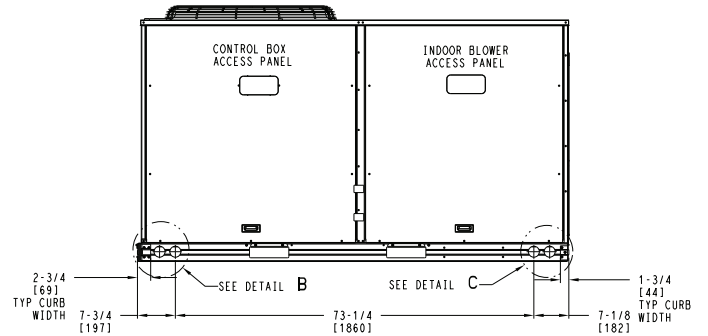

FRONT

ITC CLASSIFICATION U.S. ECCN:NSR	SHEET 3 OF 3	DATE 06/01/21	SUPERCEDES -	RAV-150 SINGLE ZONE ELECTRICAL COOLING WITH ELECTRIC HEAT	48TM006410	REV -
-------------------------------------	-----------------	------------------	-----------------	--	------------	----------

RAV180 BASE UNIT DIMENSIONS

- NOTES:
1. DIMENSIONS ARE IN INCHES, DIMENSIONS IN [] ARE IN MILLIMETERS.
 2. CENTER OF GRAVITY
 3. DIRECTION OF AIR FLOW



THIS DOCUMENT IS THE PROPERTY OF CARRIER CORPORATION AND IS DELIVERED UPON THE EXPRESS CONDITION THAT THE CONTENTS WILL NOT BE DISCLOSED OR USED WITHOUT WRITTEN CONSENT.

SUBMISSION OF THESE DRAWINGS OR DOCUMENTS DOES NOT CONSTITUTE PART PERFORMANCE OR ACCEPTANCE OF CONTRACT.

CONNECTION SIZES		
B	2 1/2" [64]	DIA POWER SUPPLY HOLE
D	7/8" [22]	DIA FIELD CONTROL WIRING HOLE
E	3/4"-14	NPT CONDENSATE DRAIN
F	7/8" [22]	DIA FIELD CONVENIENCE OUTLET HOLE

THRU-THE-BASE CHART THESE HOLES REQUIRED FOR USE CRBTMPW005A00, 006A00, 007A00				
ACCESSORY NO.	W	THREADED CONDUIT SIZE	WIRE USE	REQ'D HOLE SIZES (MAX.)
005	W	1/2"	ACC.	7/8" [22.2]
	X	1/2"	24V	7/8" [22.2]
	Y	1 1/4"	POWER	1 1/2" [38.1]
006	W	1/2"	ACC.	7/8" [22.2]
	X	1/2"	24V	7/8" [22.2]
	Y	1 1/2"	POWER	2" [50.8]
007	W	1/2"	ACC.	7/8" [22.2]
	X	1/2"	24V	7/8" [22.2]
	Y	2"	POWER	2 1/2" [63.5]

FOR "THRU-THE-BASEPAN" FACTORY OPTION, FITTINGS FOR X & Y ARE PROVIDED AS SPECIFIED ON "006".

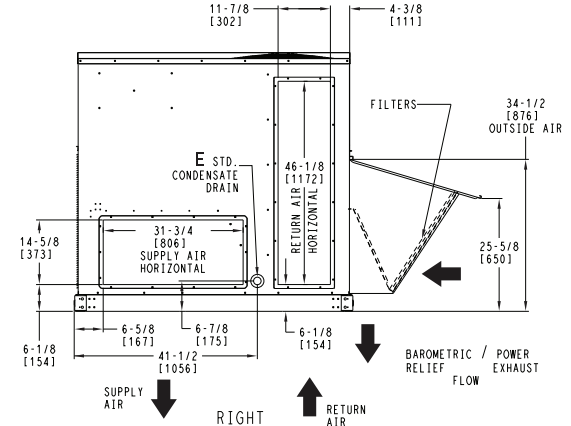
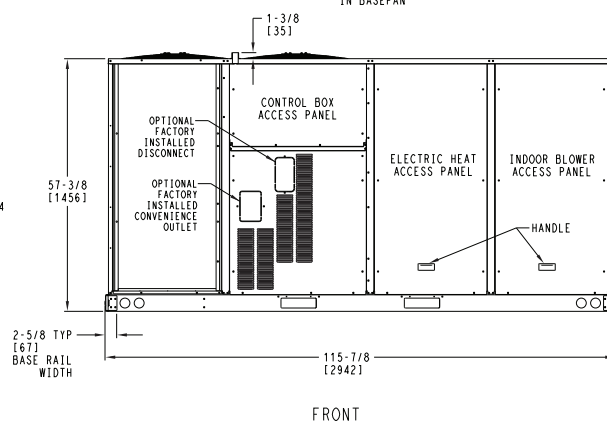
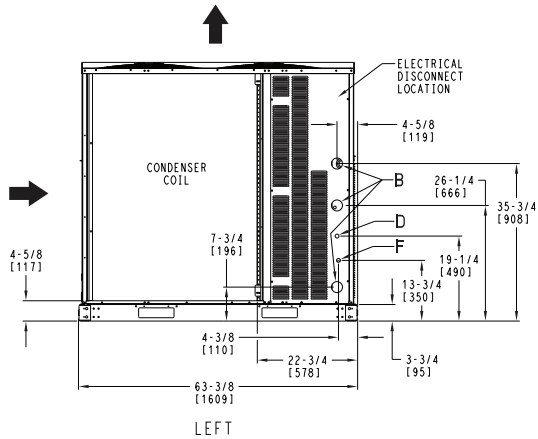
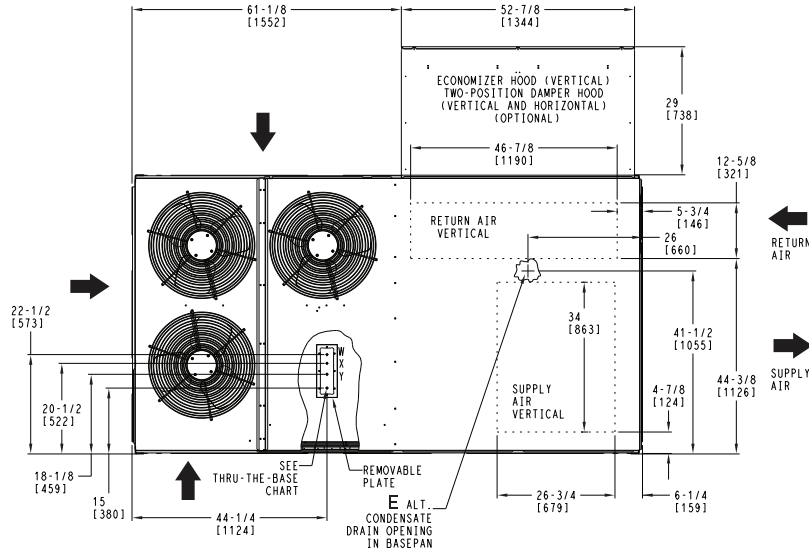
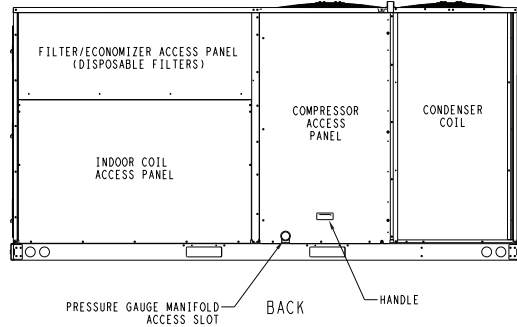

ITC CLASSIFICATION	SHEET	DATE	SUPERCEDES	RAV 180 SINGLE ZONE ELECTRICAL COOLING WITH ELECTRIC HEAT	50TM002141	REV
U.S. ECCN:NSR	1 OF 2	06/17/21	-			-

RAV180 BASE UNIT DIMENSIONS (cont)

UNIT	STD UNIT WEIGHT		CORNER WEIGHT (A)		CORNER WEIGHT (B)		CORNER WEIGHT (C)		CORNER WEIGHT (D)		C.G.		
	LBS.	KG.	LBS.	KG.	LBS.	KG.	LBS.	KG.	LBS.	KG.	X	Y	Z
RAV-180	1325	601	370	168	312	142	294	133	349	158	53 [1345]	30 3/4 [781]	22 [559]

STANDARD UNIT WEIGHT IS WITHOUT ELECTRIC HEAT & WITHOUT PACKAGING.
FOR OPTIONS & ACCESSORIES, REFER TO THE PRODUCT DATA CATALOG.

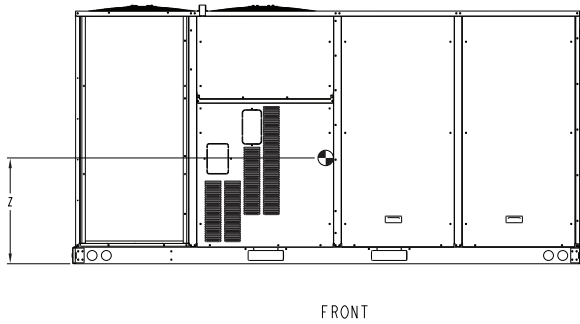
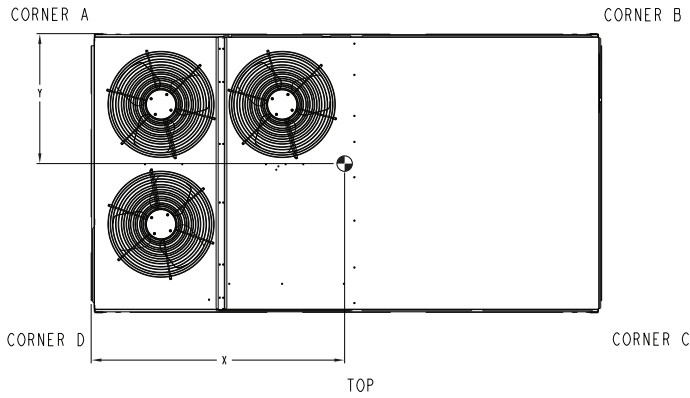

THIS DOCUMENT IS THE PROPERTY OF CARRIER CORPORATION AND IS DELIVERED UPON THE EXPRESS CONDITION THAT THE CONTENTS WILL NOT BE DISCLOSED OR USED WITHOUT WRITTEN CONSENT.

SUBMISSION OF THESE DRAWINGS OR DOCUMENTS DOES NOT CONSTITUTE PART PERFORMANCE OR ACCEPTANCE OF CONTRACT.

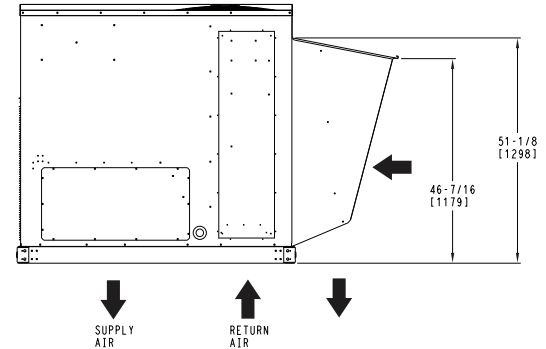
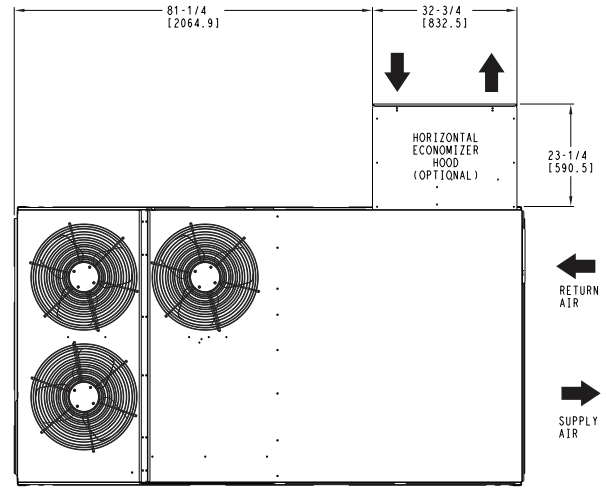

HORIZONTAL ECONOMIZER

ITC CLASSIFICATION U.S. ECCN:NSR	SHEET 2 OF 2	DATE 06/17/21	SUPERCEDES -	RAV 180 SINGLE ZONE ELECTRICAL COOLING WITH ELECTRIC HEAT	50TM002141	REV -
-------------------------------------	-----------------	------------------	-----------------	--	------------	----------

Base unit dimensions (cont)

RAV180 BASE UNIT DIMENSIONS — CLEARANCE

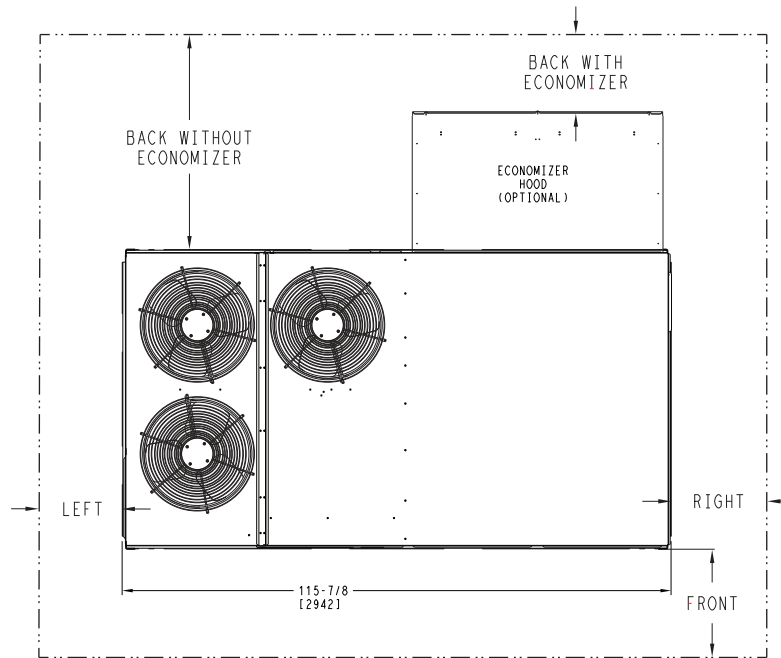

CLEARANCE^{a, b}

SURFACE	Service with Conductive Barrier	Service with Non-conductive Barrier	Operating Clearance
FRONT	48 in. (1219 mm)	36 in. (914 mm)	18 in. (457 mm)
LEFT	48 in. (1219 mm)	42 in. (1067 mm)	18 in. (457 mm)
BACK W/O ECONOMIZER	48 in. (1219 mm)	42 in. (1067 mm)	18 in. (457 mm)
BACK W/ ECONOMIZER	36 in. (914 mm)	36 in. (914 mm)	18 in. (457 mm)
RIGHT	36 in. (914 mm)	36 in. (914 mm)	18 in. (457 mm)
TOP	72 in. (1829 mm)	72 in. (1829 mm)	72 in. (1829 mm)

NOTE(S):

- a. For all minimum clearances local codes or jurisdictions may prevail.
- b. See page 27 for RAV090-120 clearances. See page 30 for RAV150 clearances.

ROOF CURB DIMENSIONS — RGV/RAV090-150

ROOF CURB ACCESSORY #	A
CRRFCURB003A01	14" [356]
CRRFCURB004A01	24" [610]

- NOTES:
 1. ROOFCURB ACCESSORY IS SHIPPED DISASSEMBLED.
 2. INSULATED PANELS: 25.4 [1"] THK. POLYURETHANE FOAM, 44.5 [1-3/4] # DENSITY.
 3. DIMENSIONS IN [] ARE IN MILLIMETERS.
 4. ROOFCURB: 18 GAGE STEEL.
 5. ATTACH DUCTWORK TO CURB. (FLANGES OF DUCT REST ON CURB).
 6. SERVICE CLEARANCE 4 FEET ON EACH SIDE.
 7. DIRECTION OF AIR FLOW.
 8. CONNECTOR PACKAGE CRBTMPWR002A01 IS FOR THRU-THE-CURB GAS TYPE PACKAGE CRBTMPWR004A01 IS FOR THRU-THE-BOTTOM TYPE GAS CONNECTIONS.

CONNECTOR PKG. ACC.	GAS CONNECTION TYPE	GAS FITTING	POWER WIRING FITTING	CONTROL WIRING FITTING	ACCESSORY CONVENIENCE OUTLET WIRING CONNECTOR
CRBTMPWR002A01	THRU THE CURB	3/4" [19] NPT	1 1/4" [31.7] NPT	1/2" [12.7] NPT	1/2" [12.7] NPT
CRBTMPWR004A01	THRU THE BOTTOM				

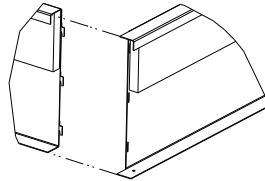
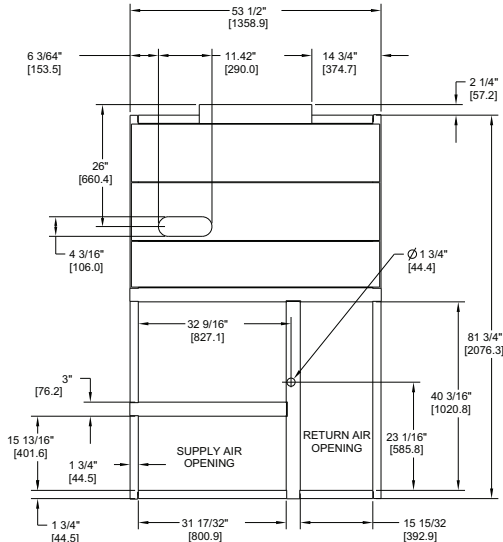

VIEW "B"
CORNER DETAIL

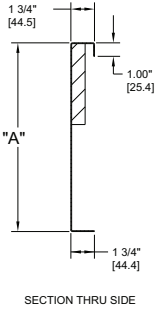
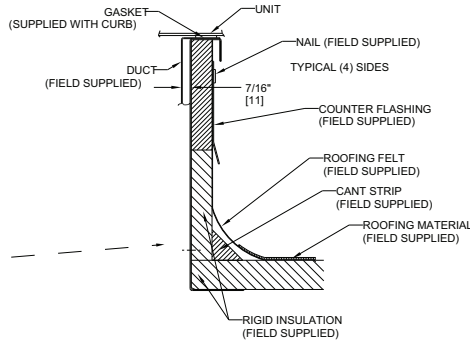

SECTION THRU SIDE

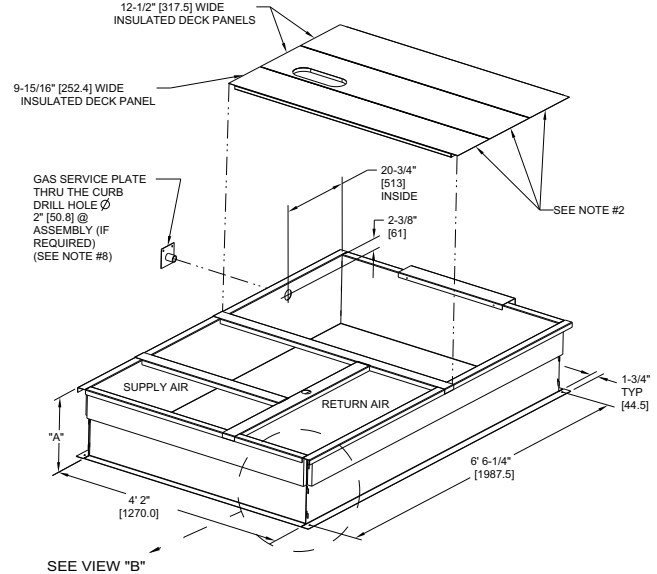

SEE VIEW "B"

CERTIFIED DRAWING

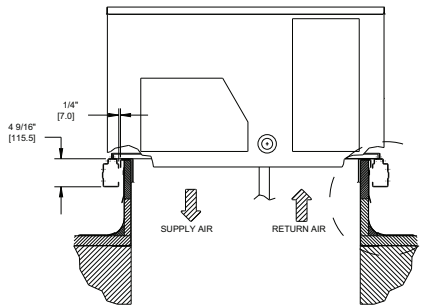

REV	REVISION RECORD	DATE	BY	CHK'D	APP'D	ECN NO.
C	6' 61/4" WAS 6' 7 1/8", 4' 2" WAS 4' 2 13/16"; 18 GA WAS 16 GA.; 15 13/16" WAS 15 15/16"; NAIL FIELD SUPPLIED WAS WITH CURB	4/22/13	MMC	-	-	1067898

DRAWING RELEASE LEVEL:		PRODUCTION			THIS DOCUMENT AND THE INFORMATION CONTAINED THEREIN IS PROPRIETARY TO CARRIER CORPORATION AND SHALL NOT BE USED OR DISCLOSED TO OTHERS, IN WHOLE OR IN PART, WITHOUT THE WRITTEN AUTHORIZATION OF CARRIER CORPORATION.	
THIRD ANGLE PROJECTION		UNLESS OTHERWISE SPECIFIED DIMENSIONS ARE IN INCHES TOLERANCES ON:			TITLE	
MATERIAL	-	1 DEC	2 DEC	3 DEC	ANG	CURB ASY, ROOF
	-	±	±	±	±	
ENGINEERING REQUIREMENTS	T-005, Y-002	AUTHORIZATION NUMBER			SIZE	DRAWING NUMBER
	-	1029120			D	50HJ405012
WEIGHT:	-	ENGINEERING			SCALE	REV
	-	MANUFACTURING			N/A	C
SURFACE FINISH	-	DRAFTER			SHEET 5 OF 5	
	-	CHECKER			DISTRIBUTION	
	-	MODEL (INTERNAL USE ONLY)			-	

ROOF CURB DIMENSIONS — RGV/RAV180

- NOTES:
 1. ROOFCURB ACCESSORY IS SHIPPED DISASSEMBLED.
 2. INSULATED PANELS: 1/2" THK. NEOPRENE FOAM, 1.0# DENSITY.
 3. DIMENSIONS IN [] ARE IN MILLIMETERS.
 4. ROOFCURB SIDEWALLS: 16 GAGE STEEL.
 5. ATTACH DUCTWORK TO CURB: (FLANGES OF DUCT REST ON CURB).
 6. SERVICE CLEARANCE 4 FT ON EACH SIDE.
 7. DIRECTION OF AIR FLOW.
 8. "L" & "S" DESIGNATIONS DENOTE LOCATION OF COMMON CROSS RAIL.
 (POSITION "L" FOR LARGE DUCT OPENING CURB).

ROOF CURB ACCESSORY #	A
CRRFCURB074A00	14" [356]
CRRFCURB075A00	24" [610]

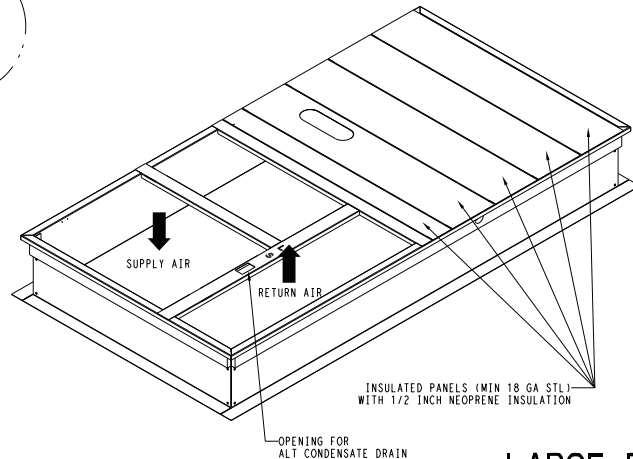
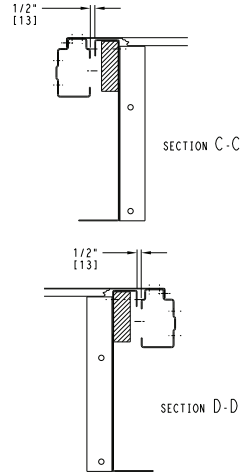
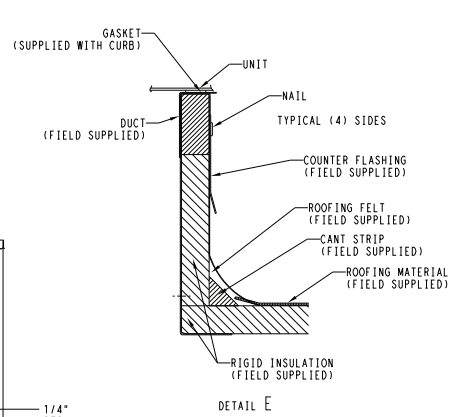
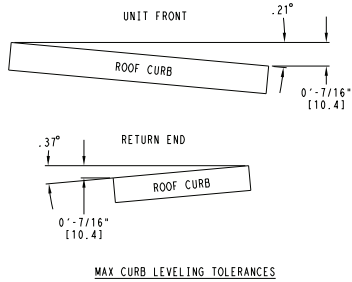
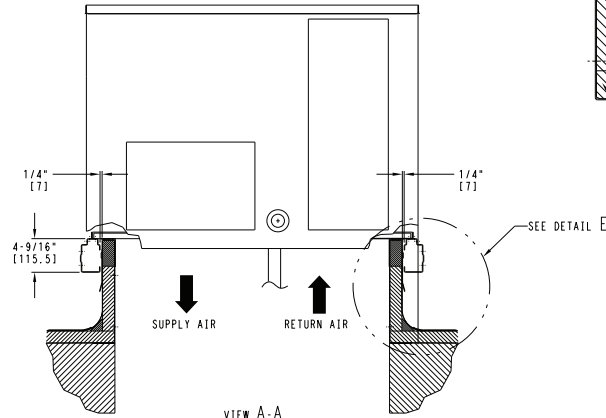
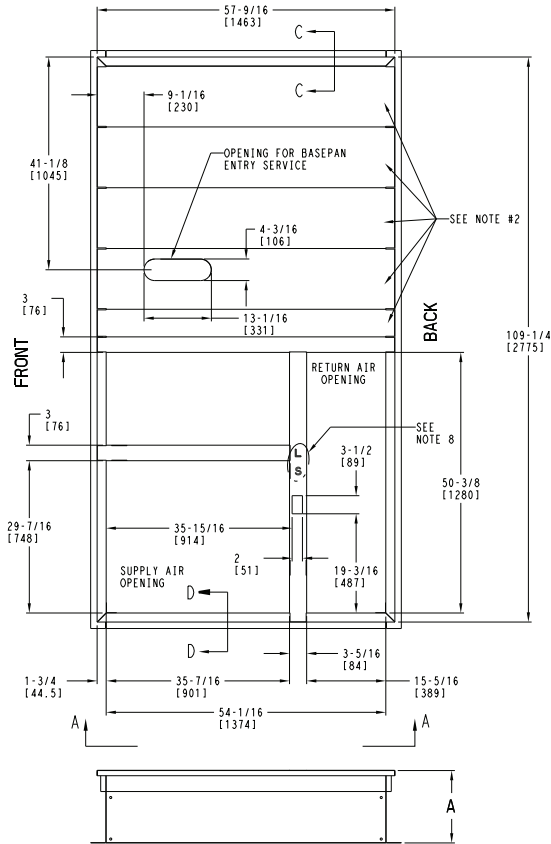

LARGE DUCT OPENINGS

50TM500780 REV B

Performance data

RGV/RAV090 TWO-STAGE COOLING CAPACITIES

RGV/RAV090			AMBIENT TEMPERATURE (°F)																
			85			95			105			115			125				
			EAT (db)			EAT (db)			EAT (db)			EAT (db)			EAT (db)				
			75	80	85	75	80	85	75	80	85	75	80	85	75	80	85		
2250 cfm	EAT (wb)	58	TC	77.2	77.2	84.6	73.2	73.2	80.4	68.3	68.3	77.8	63.9	63.9	72.9	59.0	59.0	67.6	
			SHC	65.1	74.8	84.6	61.6	71.0	80.4	58.8	68.3	77.8	54.8	63.9	72.9	50.4	59.0	67.6	
		62	TC	81.8	81.8	81.8	77.0	77.0	78.0	71.8	71.8	75.0	66.3	66.3	71.7	60.4	60.4	68.1	
			SHC	59.0	69.9	80.8	56.2	67.1	78.0	53.2	64.1	75.0	50.0	60.9	71.7	46.6	57.3	68.1	
		67	TC	90.7	90.7	90.7	85.6	85.6	85.6	80.1	80.1	80.1	74.1	74.1	74.1	67.7	67.7	67.7	
			SHC	48.5	59.2	70.0	45.6	56.5	67.3	42.7	53.6	64.5	39.6	50.5	61.5	36.4	47.3	58.3	
	72	TC	100.6	100.6	100.6	95.0	95.0	95.0	89.1	89.1	89.1	82.7	82.7	82.7	75.8	75.8	75.8		
		SHC	38.0	48.4	58.7	35.1	45.6	56.1	32.1	42.8	53.4	29.0	39.7	50.5	25.7	36.5	47.4		
	76	TC	—	109.2	109.2	—	103.5	103.5	—	97.0	97.0	—	90.1	90.1	—	82.7	82.7		
		SHC	—	39.2	51.6	—	36.4	48.7	—	33.8	46.2	—	30.9	40.4	—	27.8	38.0		
	2650 cfm	EAT (wb)	58	TC	81.2	81.2	92.1	77.1	77.1	87.6	72.8	72.8	82.8	68.0	68.0	77.6	62.8	62.8	71.9
				SHC	70.4	81.2	92.1	66.7	77.1	87.6	62.7	72.8	82.8	58.5	68.0	77.6	53.8	62.8	71.9
62			TC	84.8	84.8	89.1	79.8	79.8	86.1	74.5	74.5	82.9	68.8	68.8	79.0	64.0	64.0	71.7	
			SHC	64.1	76.6	89.1	61.2	73.7	86.1	58.0	70.5	82.9	54.5	66.8	79.0	49.3	60.5	71.7	
67			TC	93.9	93.9	93.9	88.5	88.5	88.5	82.7	82.7	82.7	76.5	76.5	76.5	69.8	69.8	69.8	
			SHC	52.0	64.5	77.1	49.1	61.7	74.3	46.1	58.8	71.4	43.0	55.6	68.3	39.7	52.3	65.0	
72		TC	103.8	103.8	103.8	98.0	98.0	98.0	91.8	91.8	91.8	85.1	85.1	85.1	77.9	77.9	77.9		
		SHC	39.6	51.9	64.1	36.7	49.1	61.4	33.7	46.1	58.6	30.5	43.0	55.6	27.2	39.8	52.3		
76		TC	—	112.5	112.5	—	106.3	106.3	—	99.6	99.6	—	92.4	92.4	—	84.7	84.7		
		SHC	—	41.5	56.0	—	38.7	49.3	—	35.9	47.3	—	32.8	44.8	—	29.6	41.9		
3000 cfm		EAT (wb)	58	TC	84.9	84.9	96.2	80.6	80.6	91.4	76.0	76.0	86.4	71.1	71.1	81.0	65.6	65.6	74.9
				SHC	73.7	84.9	96.2	69.7	80.6	91.4	65.6	76.0	86.4	61.1	71.1	81.0	56.2	65.6	74.9
	62		TC	87.0	87.0	95.8	81.7	81.7	92.1	76.6	76.6	88.1	72.9	72.9	78.4	66.9	66.9	74.1	
			SHC	68.1	82.0	95.8	64.8	78.4	92.1	61.3	74.7	88.1	55.1	66.8	78.4	51.3	62.7	74.1	
	67		TC	96.1	96.1	96.1	90.5	90.5	90.5	84.5	84.5	84.5	78.1	78.1	78.1	71.2	71.2	71.2	
			SHC	54.8	68.9	83.0	51.9	66.0	80.1	48.9	63.0	77.1	45.7	59.8	73.9	42.3	56.5	70.6	
	72	TC	106.0	106.0	106.0	100.0	100.0	100.0	93.6	93.6	93.6	86.7	86.7	86.7	79.3	79.3	79.3		
		SHC	40.9	54.7	68.6	38.0	51.9	65.8	34.9	48.9	62.9	31.7	45.7	59.7	28.4	42.4	56.5		
	76	TC	—	114.6	114.6	—	108.2	108.2	—	101.3	101.3	—	94.0	94.0	—	86.0	86.0		
		SHC	—	43.2	55.5	—	40.4	53.3	—	37.4	50.8	—	34.3	48.0	—	31.0	44.8		
	3400 cfm	EAT (wb)	58	TC	88.5	88.5	100.2	84.0	84.0	95.2	79.1	79.1	89.9	73.9	73.9	84.2	68.3	68.3	77.9
				SHC	76.8	88.5	100.2	72.7	84.0	95.2	68.4	79.1	89.9	63.7	73.9	84.2	58.6	68.3	77.9
62			TC	89.3	89.3	101.7	84.6	84.6	97.2	80.8	80.8	88.0	75.0	75.0	84.2	68.3	68.3	81.2	
			SHC	71.8	86.8	101.7	68.2	82.7	97.2	62.2	75.1	88.0	58.7	71.5	84.2	55.4	68.3	81.2	
67			TC	98.0	98.0	98.0	92.3	92.3	92.3	86.2	86.2	86.2	79.6	79.6	80.1	72.5	72.5	76.6	
			SHC	57.9	73.6	89.3	55.0	70.7	86.4	51.9	67.6	83.4	48.7	64.4	80.1	45.2	60.9	76.6	
72		TC	108.0	108.0	108.0	101.8	101.8	101.8	95.3	95.3	95.3	88.2	88.2	88.2	80.6	80.6	80.6		
		SHC	42.3	57.8	73.3	39.3	54.9	70.5	36.2	51.9	67.5	33.0	48.7	64.3	29.6	45.3	61.0		
76		TC	—	116.6	116.6	—	110.0	110.0	—	102.9	102.9	—	95.4	95.4	—	87.3	87.3		
		SHC	—	44.9	59.6	—	42.1	57.0	—	39.1	54.3	—	35.9	51.3	—	32.6	48.0		
3750 cfm		EAT (wb)	58	TC	91.2	91.2	103.2	86.5	86.5	98.1	81.5	81.5	92.5	76.1	76.1	86.6	70.2	70.2	80.1
				SHC	79.2	91.2	103.2	75.0	86.5	98.1	70.5	81.5	92.5	65.6	76.1	86.6	60.3	70.2	80.1
	62		TC	93.3	93.3	99.3	86.6	86.6	102.0	82.0	82.0	94.4	76.2	76.2	90.2	70.3	70.3	83.5	
			SHC	71.5	85.4	99.3	71.2	86.6	102.0	65.9	80.1	94.4	62.1	76.2	90.2	57.1	70.3	83.5	
	67		TC	99.5	99.5	99.5	93.6	93.6	93.6	87.4	87.4	88.6	80.6	80.6	85.2	73.4	73.4	81.5	
			SHC	60.5	77.6	94.7	57.5	74.6	91.7	54.4	71.5	88.6	51.1	68.2	85.2	47.5	64.5	81.5	
	72	TC	109.4	109.4	109.4	103.2	103.2	103.2	96.5	96.5	96.5	89.2	89.2	89.2	81.5	81.5	81.5		
		SHC	43.4	60.4	77.3	40.4	57.4	74.4	37.3	54.3	71.4	34.0	51.1	68.2	30.7	47.7	64.8		
	76	TC	—	118.0	118.0	—	111.3	111.3	—	104.1	104.1	—	96.4	96.4	—	88.2	88.2		
		SHC	—	46.4	62.7	—	43.5	60.0	—	40.4	57.1	—	37.2	54.0	—	33.8	50.7		

LEGEND

- Do Not Operate
- cfm — Cubic Feet Per Minute (Supply Air)
- EAT (db) — Entering Air Temperature (dry bulb)
- EAT (wb) — Entering Air Temperature (wet bulb)
- SHC — Sensible Heat Capacity (1000 Btuh) Gross
- TC — Total Capacity (1000 Btuh) Gross

NOTE: See minimum-maximum airflow ratings on page 6.

Performance data (cont)

RGV/RAV090 SINGLE-STAGE COOLING CAPACITIES

RGV/RAV090			AMBIENT TEMPERATURE (°F)																
			85			95			105			115			125				
			EAT (db)			EAT (db)			EAT (db)			EAT (db)			EAT (db)				
			75	80	85	75	80	85	75	80	85	75	80	85	75	80	85		
900 cfm	EAT (wb)	58	TC	39.1	39.1	44.6	36.6	36.6	42.0	34.1	34.1	39.2	31.4	31.4	36.3	28.5	28.5	33.1	
			SHC	33.6	39.1	44.6	31.3	36.6	42.0	29.0	34.1	39.2	26.5	31.4	36.3	23.9	28.5	33.1	
		62	TC	42.2	42.2	42.2	39.2	39.2	40.0	36.1	36.1	38.0	32.7	32.7	35.9	29.2	29.2	33.7	
			SHC	30.1	36.0	41.9	28.2	34.1	40.0	26.2	32.1	38.0	24.1	30.0	35.9	21.9	27.8	33.7	
		67	TC	47.4	47.4	47.4	44.3	44.3	44.3	40.9	40.9	40.9	37.4	37.4	37.4	33.6	33.6	33.6	
			SHC	24.8	30.7	36.5	22.9	28.8	34.6	21.0	26.8	32.7	18.9	24.8	30.7	16.8	22.7	28.6	
	72	TC	53.1	53.1	53.1	49.8	49.8	49.8	46.2	46.2	46.2	42.5	42.5	42.5	38.5	38.5	38.5		
		SHC	19.6	25.2	30.9	17.7	23.4	29.1	15.7	21.4	27.2	13.6	19.4	25.2	11.5	17.3	23.1		
	76	TC	—	58.1	58.1	—	54.6	54.6	—	50.8	50.8	—	46.8	46.8	—	42.5	42.5		
		SHC	—	20.6	26.9	—	18.8	25.1	—	17.0	23.3	—	15.0	20.3	—	12.9	18.4		
	1050 cfm	EAT (wb)	58	TC	42.0	42.0	47.8	39.4	39.4	45.0	36.7	36.7	42.1	33.9	33.9	39.0	30.8	30.8	35.6
				SHC	36.2	42.0	47.8	33.8	39.4	45.0	31.3	36.7	42.1	28.7	33.9	39.0	25.9	30.8	35.6
62			TC	44.0	44.0	46.7	40.9	40.9	44.7	37.6	37.6	42.5	34.2	34.2	40.1	30.8	30.8	37.3	
			SHC	33.1	39.9	46.7	31.1	37.9	44.7	29.0	35.8	42.5	26.7	33.4	40.1	24.3	30.8	37.3	
67			TC	49.3	49.3	49.3	46.0	46.0	46.0	42.5	42.5	42.5	38.8	38.8	38.8	34.9	34.9	34.9	
			SHC	26.9	33.6	40.4	24.9	31.7	38.5	22.9	29.7	36.5	20.8	27.7	34.5	18.6	25.5	32.3	
72		TC	55.1	55.1	55.1	51.6	51.6	51.6	47.9	47.9	47.9	44.0	44.0	44.0	39.7	39.7	39.7		
		SHC	20.6	27.3	33.9	18.6	25.3	32.0	16.6	23.3	30.1	14.5	21.3	28.1	12.3	19.1	25.9		
76		TC	—	60.0	60.0	—	56.3	56.3	—	52.4	52.4	—	48.2	48.2	—	—	—		
		SHC	—	22.0	29.4	—	20.1	26.1	—	18.1	24.4	—	16.0	22.5	—	—	—		
1200 cfm		EAT (wb)	58	TC	45.0	45.0	51.2	42.3	42.3	48.2	39.4	39.4	45.1	36.4	36.4	41.8	33.1	33.1	38.2
				SHC	38.9	45.0	51.2	36.4	42.3	48.2	33.7	39.4	45.1	30.9	36.4	41.8	27.9	33.1	38.2
	62		TC	45.7	45.7	52.0	42.6	42.6	49.5	39.8	39.8	46.3	36.4	36.4	43.7	33.1	33.1	40.0	
			SHC	36.3	44.2	52.0	34.1	41.8	49.5	31.5	38.9	46.3	29.2	36.4	43.7	26.3	33.1	40.0	
	67		TC	51.1	51.1	51.1	47.6	47.6	47.6	44.0	44.0	44.0	40.2	40.2	40.2	36.1	36.1	36.8	
			SHC	29.2	37.2	45.1	27.2	35.2	43.2	25.1	33.1	41.1	23.0	31.0	39.0	20.8	28.8	36.8	
	72	TC	56.9	56.9	56.9	53.2	53.2	53.2	49.4	49.4	49.4	45.3	45.3	45.3	40.9	40.9	40.9		
		SHC	21.7	29.6	37.5	19.7	27.6	35.5	17.6	25.6	33.5	15.5	23.5	31.4	13.3	21.2	29.2		
	76	TC	—	61.8	61.8	—	57.9	57.9	—	53.8	53.8	—	—	—	—	—	—		
		SHC	—	23.3	30.7	—	21.4	28.9	—	19.3	27.0	—	—	—	—	—	—		
	1350 cfm	EAT (wb)	58	TC	47.1	47.1	53.4	44.2	44.2	50.4	41.2	41.2	47.1	38.0	38.0	43.7	34.6	34.6	39.9
				SHC	40.7	47.1	53.4	38.0	44.2	50.4	35.3	41.2	47.1	32.4	38.0	43.7	29.3	34.6	39.9
62			TC	47.5	47.5	54.9	44.6	44.6	51.7	41.3	41.3	49.2	38.1	38.1	45.6	34.7	34.7	41.7	
			SHC	38.2	46.6	54.9	35.7	43.7	51.7	33.4	41.3	49.2	30.6	38.1	45.6	27.6	34.7	41.7	
67			TC	52.2	52.2	52.2	48.6	48.6	48.6	44.9	44.9	44.9	41.0	41.0	42.5	36.8	36.8	40.2	
			SHC	30.9	39.8	48.7	28.9	37.8	46.7	26.8	35.8	44.7	24.7	33.6	42.5	22.4	31.3	40.2	
72		TC	58.0	58.0	58.0	54.3	54.3	54.3	50.3	50.3	50.3	46.1	46.1	46.1	41.6	41.6	41.6		
		SHC	22.5	31.3	40.1	20.5	29.3	38.1	18.4	27.2	36.1	16.2	25.1	33.9	14.0	22.8	31.7		
76		TC	—	62.8	62.8	—	58.8	58.8	—	—	—	—	—	—	—	—	—		
		SHC	—	24.3	32.7	—	22.3	30.8	—	—	—	—	—	—	—	—	—		
2520 cfm		EAT (wb)	58	TC	49.2	49.2	55.9	46.2	46.2	52.6	43.1	43.1	49.2	39.8	39.8	45.6	36.2	36.2	41.7
				SHC	42.6	49.2	55.9	39.9	46.2	52.6	37.0	43.1	49.2	34.0	39.8	45.6	30.7	36.2	41.7
	62		TC	48.7	48.7	58.0	46.3	46.3	54.8	43.2	43.2	51.3	39.8	39.8	47.6	36.3	36.3	43.6	
			SHC	39.3	48.7	58.0	37.8	46.3	54.8	35.0	43.2	51.3	32.1	39.8	47.6	28.9	36.3	43.6	
	67		TC	53.3	53.3	53.3	49.6	49.6	51.0	45.8	45.8	48.8	41.8	41.8	46.6	37.5	37.5	44.1	
			SHC	33.0	43.0	53.0	30.9	41.0	51.0	28.8	38.8	48.8	26.6	36.6	46.6	24.3	34.2	44.1	
	72	TC	59.1	59.1	59.1	55.3	55.3	55.3	51.2	51.2	51.2	46.9	46.9	46.9	42.3	42.3	42.3		
		SHC	23.4	33.3	43.3	21.3	31.3	41.2	19.2	29.2	39.2	17.1	27.0	37.0	14.8	24.7	34.7		
	76	TC	—	—	—	—	—	—	—	—	—	—	—	—	—	—	—		
		SHC	—	—	—	—	—	—	—	—	—	—	—	—	—	—	—		

LEGEND

- Do Not Operate
- cfm — Cubic Feet Per Minute (Supply Air)
- EAT (db) — Entering Air Temperature (dry bulb)
- EAT (wb) — Entering Air Temperature (wet bulb)
- SHC — Sensible Heat Capacity (1000 Btuh) Gross
- TC — Total Capacity (1000 Btuh) Gross

NOTE: See minimum-maximum airflow ratings on page 6.

Performance data (cont)

RGV/RAV090 — UNIT WITH HOT GAS RE-HEAT SYSTEM IN SUBCOOLING MODE — COOLING CAPACITIES

TEMP (°F) AIR ENTERING CONDENSER (Edb)		AIR ENTERING EVAPORATOR — SCFM/BF (80°F db)								
		2250/0.14			3000/0.15			3750/0.17		
		Air Entering Evaporator — Ewb (°F)								
		72	67	62	72	67	62	72	67	62
75	TC	95.0	86.0	77.0	104.0	93.0	83.0	108.0	97.0	87.0
	SHC	38.0	49.0	60.0	47.0	60.0	72.0	53.0	69.0	83.0
	kW	6.4	6.4	6.3	6.6	6.5	6.4	6.6	6.5	6.4
85	TC	86.0	81.0	71.0	97.0	86.0	77.0	101.0	91.0	81.0
	SHC	29.0	44.0	54.0	40.0	53.0	67.0	46.0	63.0	76.0
	kW	6.9	7.0	7.0	7.2	7.1	7.0	7.2	7.2	7.1
95	TC	84.0	74.0	65.0	90.0	80.0	71.0	94.0	83.0	74.0
	SHC	28.0	38.0	49.0	34.0	47.0	61.0	40.0	56.0	70.0
	kW	7.8	7.7	7.7	7.9	7.8	7.7	8.0	7.9	7.8
105	TC	77.0	68.0	59.0	82.0	73.0	64.0	86.0	76.0	68.0
	SHC	22.0	32.0	43.0	27.0	41.0	55.0	33.0	49.0	64.0
	kW	8.7	8.5	8.4	8.8	8.6	8.5	8.8	8.7	8.6
115	TC	70.0	61.0	53.0	74.0	65.0	57.0	78.0	68.0	60.0
	SHC	15.0	26.0	37.0	20.0	35.0	49.0	25.0	42.0	57.0
	kW	9.5	9.4	9.3	9.6	9.5	9.4	9.7	9.5	9.4
125	TC	62.0	54.0	46.0	66.0	58.0	50.0	69.0	60.0	53.0
	SHC	8.0	20.0	31.0	13.0	28.0	42.0	18.0	35.0	50.0
	kW	10.5	10.4	10.3	10.6	10.5	10.3	10.7	10.5	10.4

RGV/RAV090 — UNIT WITH HOT GAS RE-HEAT SYSTEM IN HOT GAS REHEAT MODE — COOLING CAPACITIES

TEMP (°F) AIR ENTERING CONDENSER (Edb)		AIR ENTERING EVAPORATOR — Ewb (°F)								
		75 Dry Bulb 62.5 Wet Bulb (50% Relative)			75 Dry Bulb 64 Wet Bulb (56% Relative)			75 Dry Bulb 65.3 Wet Bulb (60% Relative)		
		Air Entering Evaporator — cfm								
		2250	3000	3750	2250	3000	3750	2250	3000	3750
80	TC	35.0	39.0	41.0	37.0	40.0	42.0	38.0	41.0	43.0
	SHC	8.0	14.0	21.0	4.0	9.0	15.0	0.0	5.0	10.0
	kW	6.6	6.6	6.6	6.6	6.6	6.6	6.6	6.6	6.6
75	TC	37.0	41.0	43.0	39.0	42.0	44.0	40.0	43.0	46.0
	SHC	9.0	16.0	23.0	6.0	12.0	17.0	2.0	7.0	12.0
	kW	5.9	5.9	6.0	5.9	6.0	6.0	6.0	6.1	6.1
70	TC	40.0	43.0	45.0	41.0	44.0	47.0	42.0	46.0	48.0
	SHC	11.0	18.0	25.0	8.0	13.0	19.0	4.0	9.0	14.0
	kW	5.7	5.7	5.7	5.7	5.7	5.7	5.7	5.7	5.7
60	TC	44.0	47.0	50.0	45.0	49.0	51.0	47.0	50.0	53.0
	SHC	15.0	22.0	29.0	11.0	17.0	23.0	8.0	13.0	18.0
	kW	5.7	5.7	5.7	5.7	5.7	5.7	5.7	5.7	5.7
50	TC	47.0	51.0	54.0	49.0	53.0	55.0	51.0	54.0	57.0
	SHC	19.0	26.0	33.0	15.0	21.0	27.0	12.0	17.0	22.0
	kW	5.7	5.6	5.6	5.6	5.6	5.6	5.6	5.6	5.6
40	TC	51.0	55.0	58.0	53.0	57.0	60.0	54.0	59.0	61.0
	SHC	22.0	30.0	37.0	18.0	25.0	31.0	15.0	21.0	26.0
	kW	5.6	5.6	5.6	5.6	5.6	5.6	5.6	5.6	5.6

LEGEND

- Edb** — Entering Dry Bulb
- Ewb** — Entering Wet Bulb
- kW** — Compressor Power Input
- SCFM/BF** — Standard Cubic Feet per Minute/Bypass Factor
- SHC** — Sensible Heat Capacity (1000 Btuh) Gross
- TC** — Total Capacity (1000 Btuh) Gross

Performance data (cont)

RGV/RAV102 TWO-STAGE COOLING CAPACITIES

RGV/RAV102			AMBIENT TEMPERATURE (°F)																
			85			95			105			115			125				
			EAT (db)			EAT (db)			EAT (db)			EAT (db)			EAT (db)				
			75	80	85	75	80	85	75	80	85	75	80	85	75	80	85		
2550 cfm	EAT (wb)	58	TC	89.0	89.0	100.5	85.0	85.0	96.1	80.8	80.8	91.4	76.3	76.3	86.4	71.6	71.6	81.1	
			SHC	77.5	89.0	100.5	74.0	85.0	96.1	70.3	80.8	91.4	66.3	76.3	86.4	62.1	71.6	81.1	
		62	TC	93.2	93.2	96.4	88.1	88.1	93.9	82.8	82.8	91.1	77.3	77.3	88.0	72.5	72.5	82.7	
			SHC	70.4	83.4	96.4	67.8	80.9	93.9	65.1	78.1	91.1	62.2	75.1	88.0	58.3	70.5	82.7	
		67	TC	102.4	102.4	102.4	97.0	97.0	97.0	91.3	91.3	91.3	85.3	85.3	85.3	79.0	79.0	79.0	
			SHC	57.4	70.4	83.3	54.9	67.9	81.0	52.3	65.4	78.4	49.7	62.8	75.9	47.0	60.1	73.2	
	72	TC	112.6	112.6	112.6	106.8	106.8	106.8	100.7	100.7	100.7	94.3	94.3	94.3	87.5	87.5	87.5		
		SHC	44.3	57.0	69.7	41.8	54.6	67.4	39.3	52.1	65.0	36.6	49.5	62.5	33.9	46.9	59.8		
	76	TC	—	121.3	121.3	—	115.2	115.2	—	108.7	108.7	—	101.9	101.9	—	94.7	94.7		
		SHC	—	45.9	59.9	—	43.6	54.2	—	41.3	52.9	—	38.8	50.9	—	36.1	48.6		
	3000 cfm	EAT (wb)	58	TC	94.1	94.1	106.3	89.9	89.9	101.5	85.3	85.3	96.5	80.6	80.6	91.1	75.5	75.5	85.4
				SHC	82.0	94.1	106.3	78.2	89.9	101.5	74.2	85.3	96.5	70.0	80.6	91.1	65.5	75.5	85.4
62			TC	96.1	96.1	106.2	91.0	91.0	103.2	86.7	86.7	97.7	82.4	82.4	89.1	75.6	75.6	88.9	
			SHC	76.1	91.2	106.2	73.4	88.3	103.2	69.4	83.5	97.7	63.9	76.5	89.1	62.3	75.6	88.9	
67			TC	105.5	105.5	105.5	99.9	99.9	99.9	93.9	93.9	93.9	87.6	87.6	87.6	81.0	81.0	81.2	
			SHC	61.2	76.4	91.5	58.7	73.9	89.1	56.1	71.4	86.6	53.5	68.7	84.0	50.7	65.9	81.2	
72		TC	115.8	115.8	115.8	109.8	109.8	109.8	103.4	103.4	103.4	96.7	96.7	96.7	89.5	89.5	89.5		
		SHC	45.8	60.7	75.6	43.3	58.3	73.2	40.7	55.7	70.8	38.0	53.1	68.2	35.2	50.4	65.6		
76		TC	—	124.6	124.6	—	118.3	118.3	—	111.5	111.5	—	104.4	104.4	—	—	—		
		SHC	—	47.8	61.4	—	45.5	59.5	—	43.0	57.3	—	40.5	55.1	—	—	—		
3400 cfm		EAT (wb)	58	TC	97.9	97.9	110.6	93.5	93.5	105.6	88.8	88.8	100.3	83.7	83.7	94.6	78.4	78.4	88.7
				SHC	85.3	97.9	110.6	81.4	93.5	105.6	77.2	88.8	100.3	72.7	83.7	94.6	68.0	78.4	88.7
	62		TC	98.6	98.6	113.3	94.4	94.4	107.7	89.2	89.2	103.1	83.8	83.8	98.4	78.5	78.5	92.2	
			SHC	80.4	96.8	113.3	76.5	92.1	107.7	72.8	88.0	103.1	69.2	83.8	98.4	64.7	78.5	92.2	
	67		TC	107.7	107.7	107.7	101.8	101.8	101.8	95.6	95.6	95.6	89.1	89.1	90.8	82.3	82.3	87.9	
			SHC	64.4	81.4	98.5	61.9	79.0	96.0	59.3	76.4	93.5	56.6	73.7	90.8	53.8	70.9	87.9	
	72	TC	118.0	118.0	118.0	111.8	111.8	111.8	105.1	105.1	105.1	98.2	98.2	98.2	90.9	90.9	90.9		
		SHC	46.9	63.7	80.5	44.4	61.2	78.1	41.8	58.7	75.6	39.1	56.1	73.1	36.3	53.4	70.4		
	76	TC	—	126.9	126.9	—	120.3	120.3	—	113.3	113.3	—	—	—	—	—	—		
		SHC	—	49.3	65.1	—	46.9	63.0	—	44.4	60.7	—	—	—	—	—	—		
	3850 cfm	EAT (wb)	58	TC	101.6	101.6	114.7	97.0	97.0	109.5	91.9	91.9	103.9	86.7	86.7	98.0	81.1	81.1	91.7
				SHC	88.6	101.6	114.7	84.5	97.0	109.5	80.0	91.9	103.9	75.3	86.7	98.0	70.4	81.1	91.7
62			TC	104.0	104.0	110.7	97.1	97.1	113.8	92.1	92.1	108.0	86.8	86.8	101.9	81.2	81.2	95.4	
			SHC	80.2	95.5	110.7	80.4	97.1	113.8	76.1	92.1	108.0	71.7	86.8	101.9	66.9	81.2	95.4	
67			TC	109.6	109.6	109.6	103.5	103.5	103.7	97.2	97.2	101.0	90.5	90.5	98.2	83.6	83.6	95.1	
			SHC	67.9	87.0	106.1	65.4	84.6	103.7	62.8	81.9	101.0	60.0	79.1	98.2	57.1	76.1	95.1	
72		TC	120.0	120.0	120.0	113.5	113.5	113.5	106.7	106.7	106.7	99.7	99.7	99.7	92.2	92.2	92.2		
		SHC	48.0	66.9	85.8	45.5	64.4	83.4	42.8	61.9	80.9	40.2	59.3	78.3	37.4	56.5	75.6		
76		TC	—	128.9	128.9	—	122.2	122.2	—	—	—	—	—	—	—	—	—		
		SHC	—	50.6	68.7	—	48.2	66.5	—	—	—	—	—	—	—	—	—		
4250 cfm		EAT (wb)	58	TC	104.4	104.4	117.8	99.6	99.6	112.4	94.4	94.4	106.6	88.9	88.9	100.5	83.1	83.1	94.0
				SHC	91.0	104.4	117.8	86.7	99.6	112.4	82.1	94.4	106.6	77.3	88.9	100.5	72.2	83.1	94.0
	62		TC	104.6	104.6	122.5	99.7	99.7	116.9	94.5	94.5	110.8	89.0	89.0	104.5	83.2	83.2	97.8	
			SHC	86.7	104.6	122.5	82.6	99.7	116.9	78.2	94.5	110.8	73.5	89.0	104.5	68.6	83.2	97.8	
	67		TC	110.9	110.9	112.7	104.7	104.7	110.1	98.2	98.2	107.3	91.5	91.5	104.3	84.5	84.5	101.0	
			SHC	70.9	91.8	112.7	68.3	89.2	110.1	65.6	86.5	107.3	62.8	83.6	104.3	59.9	80.5	101.0	
	72	TC	121.4	121.4	121.4	114.8	114.8	114.8	107.9	107.9	107.9	100.7	100.7	100.7	93.0	93.0	93.0		
		SHC	48.8	69.6	90.3	46.3	67.1	87.9	43.7	64.6	85.4	41.0	61.9	82.8	38.3	59.2	80.1		
	76	TC	—	130.4	130.4	—	—	—	—	—	—	—	—	—	—	—	—		
		SHC	—	51.6	71.7	—	—	—	—	—	—	—	—	—	—	—	—		

LEGEND

- Do Not Operate
- cfm — Cubic Feet Per Minute (Supply Air)
- EAT (db) — Entering Air Temperature (dry bulb)
- EAT (wb) — Entering Air Temperature (wet bulb)
- SHC — Sensible Heat Capacity (1000 Btuh) Gross
- TC — Total Capacity (1000 Btuh) Gross

NOTE: See minimum-maximum airflow ratings on page 6.

Performance data (cont)

RGV/RAV102 SINGLE-STAGE COOLING CAPACITIES

RGV/RAV102			AMBIENT TEMPERATURE (°F)																
			85			95			105			115			125				
			EAT (db)			EAT (db)			EAT (db)			EAT (db)			EAT (db)				
			75	80	85	75	80	85	75	80	85	75	80	85	75	80	85		
1275 cfm	EAT (wb)	58	TC	44.0	44.0	50.1	41.4	41.4	47.2	38.6	38.6	44.2	35.7	35.7	41.0	32.6	32.6	37.6	
			SHC	38.0	44.0	50.1	35.6	41.4	47.2	33.1	38.6	44.2	30.4	35.7	41.0	27.6	32.6	37.6	
		62	TC	46.7	46.7	47.8	43.4	43.4	45.9	40.0	40.0	43.9	36.4	36.4	41.7	32.8	32.8	39.2	
			SHC	34.4	41.1	47.8	32.4	39.2	45.9	30.4	37.1	43.9	28.2	35.0	41.7	25.9	32.6	39.2	
		67	TC	52.2	52.2	52.2	48.8	48.8	48.8	45.1	45.1	45.1	41.3	41.3	41.3	37.3	37.3	37.3	
			SHC	28.2	34.9	41.6	26.2	33.0	39.7	24.2	31.0	37.7	22.2	28.9	35.7	20.0	26.8	33.6	
	72	TC	58.1	58.1	58.1	54.5	54.5	54.5	50.7	50.7	50.7	46.6	46.6	46.6	42.3	42.3	42.3		
		SHC	22.0	28.6	35.2	20.0	26.7	33.3	18.0	24.7	31.3	15.9	22.6	29.3	13.8	20.5	27.3		
	76	TC	—	63.2	63.2	—	59.5	59.5	—	55.4	55.4	—	—	—	—	—	—		
		SHC	—	23.3	30.3	—	21.5	27.2	—	19.5	25.7	—	—	—	—	—	—		
	1500 cfm	EAT (wb)	58	TC	47.2	47.2	53.6	44.4	44.4	50.6	41.5	41.5	47.3	38.3	38.3	43.9	35.0	35.0	40.3
				SHC	40.8	47.2	53.6	38.2	44.4	50.6	35.6	41.5	47.3	32.7	38.3	43.9	29.8	35.0	40.3
62			TC	48.6	48.6	53.5	45.2	45.2	51.4	41.7	41.7	49.0	38.4	38.4	45.9	35.1	35.1	42.2	
			SHC	37.7	45.6	53.5	35.7	43.5	51.4	33.5	41.2	49.0	30.9	38.4	45.9	28.0	35.1	42.2	
67			TC	54.2	54.2	54.2	50.6	50.6	50.6	46.7	46.7	46.7	42.7	42.7	42.7	38.5	38.5	38.5	
			SHC	30.4	38.3	46.2	28.5	36.4	44.2	26.4	34.3	42.2	24.3	32.2	40.2	22.1	30.1	38.0	
72		TC	60.2	60.2	60.2	56.4	56.4	56.4	52.4	52.4	52.4	48.1	48.1	48.1	43.6	43.6	43.6		
		SHC	23.0	30.8	38.5	21.0	28.8	36.6	19.0	26.8	34.6	16.9	24.7	32.6	14.7	22.6	30.5		
76		TC	—	65.4	65.4	—	—	—	—	—	—	—	—	—	—	—	—		
		SHC	—	24.6	31.8	—	—	—	—	—	—	—	—	—	—	—	—		
1700 cfm		EAT (wb)	58	TC	49.6	49.6	56.3	46.7	46.7	53.1	43.5	43.5	49.7	40.3	40.3	46.1	36.8	36.8	42.3
				SHC	42.9	49.6	56.3	40.2	46.7	53.1	37.4	43.5	49.7	34.4	40.3	46.1	31.3	36.8	42.3
	62		TC	50.0	50.0	57.8	46.9	46.9	54.9	43.6	43.6	51.8	40.3	40.3	48.1	36.9	36.9	44.2	
			SHC	40.4	49.1	57.8	37.9	46.4	54.9	35.4	43.6	51.8	32.6	40.3	48.1	29.5	36.9	44.2	
	67		TC	55.5	55.5	55.5	51.8	51.8	51.8	47.8	47.8	47.8	43.7	44.0	44.0	39.4	39.4	41.8	
			SHC	32.3	41.2	50.1	30.3	39.2	48.1	28.3	37.2	46.1	26.1	35.0	44.0	23.9	32.9	41.8	
	72	TC	61.6	61.6	61.6	57.7	57.7	57.7	53.6	53.6	53.6	49.2	49.2	49.2	44.5	44.5	44.5		
		SHC	23.8	32.6	41.4	21.9	30.7	39.5	19.8	28.6	37.5	17.7	26.5	35.4	15.5	24.4	33.2		
	76	TC	—	—	—	—	—	—	—	—	—	—	—	—	—	—	—		
		SHC	—	—	—	—	—	—	—	—	—	—	—	—	—	—	—		
	1925 cfm	EAT (wb)	58	TC	51.9	51.9	58.8	48.8	48.8	55.5	45.5	45.5	51.9	42.1	42.1	48.1	38.5	38.5	44.2
				SHC	44.9	51.9	58.8	42.1	48.8	55.5	39.2	45.5	51.9	36.1	42.1	48.1	32.8	38.5	44.2
62			TC	51.9	51.9	61.2	48.9	48.9	57.8	45.6	45.6	54.1	42.2	42.2	50.2	38.6	38.6	46.2	
			SHC	42.7	51.9	61.2	39.9	48.9	57.8	37.1	45.6	54.1	34.1	42.2	50.2	31.0	38.6	46.2	
67			TC	56.7	56.7	56.7	52.9	52.9	52.9	48.8	48.8	50.3	44.6	44.6	48.1	40.2	40.2	45.8	
			SHC	34.4	44.4	54.4	32.3	42.4	52.4	30.2	40.3	50.3	28.1	38.1	48.1	25.8	35.8	45.8	
72		TC	62.9	62.9	62.9	58.9	58.9	58.9	54.6	54.6	54.6	50.1	50.1	50.1	—	—	—		
		SHC	24.7	34.6	44.5	22.7	32.6	42.6	20.6	30.6	40.5	18.4	28.4	38.4	—	—	—		
76		TC	—	—	—	—	—	—	—	—	—	—	—	—	—	—	—		
		SHC	—	—	—	—	—	—	—	—	—	—	—	—	—	—	—		
2125 cfm		EAT (wb)	58	TC	53.6	53.6	60.8	50.4	50.4	57.3	47.1	47.1	53.6	43.5	43.5	49.7	39.8	39.8	45.6
				SHC	46.5	53.6	60.8	43.6	50.4	57.3	40.5	47.1	53.6	37.3	43.5	49.7	34.0	39.8	45.6
	62		TC	53.7	53.7	63.2	50.5	50.5	59.7	47.1	47.1	55.9	43.6	43.6	51.9	39.9	39.9	47.6	
			SHC	44.1	53.7	63.2	41.3	50.5	59.7	38.4	47.1	55.9	35.3	43.6	51.9	32.1	39.9	47.6	
	67		TC	57.6	57.6	58.0	53.7	53.7	56.1	49.6	49.6	53.9	45.2	45.2	51.7	40.7	40.7	49.3	
			SHC	36.1	47.1	58.0	34.1	45.1	56.1	31.9	42.9	53.9	29.7	40.7	51.7	27.4	38.3	49.3	
	72	TC	63.8	63.8	63.8	59.7	59.7	59.7	55.3	55.3	55.3	—	—	—	—	—	—		
		SHC	25.4	36.3	47.2	23.4	34.3	45.2	21.3	32.2	43.2	—	—	—	—	—	—		
	76	TC	—	—	—	—	—	—	—	—	—	—	—	—	—	—	—		
		SHC	—	—	—	—	—	—	—	—	—	—	—	—	—	—	—		

LEGEND

- Do Not Operate
- cfm — Cubic Feet Per Minute (Supply Air)
- EAT (db) — Entering Air Temperature (dry bulb)
- EAT (wb) — Entering Air Temperature (wet bulb)
- SHC — Sensible Heat Capacity (1000 Btuh) Gross
- TC — Total Capacity (1000 Btuh) Gross

NOTE: See minimum-maximum airflow ratings on page 6.

Performance data (cont)

RGV/RAV102 — UNIT WITH HOT GAS RE-HEAT SYSTEM IN SUBCOOLING MODE — COOLING CAPACITIES

TEMP (°F) AIR ENTERING CONDENSER (Edb)		AIR ENTERING EVAPORATOR — SCFM/BF (80°F db)								
		2550/0.11			3400/0.14			4250/0.15		
		Air Entering Evaporator — Ewb (°F)								
		72	67	62	72	67	62	72	67	62
75	TC	108.0	96.0	86.0	108.0	97.0	90.0	119.0	107.0	97.0
	SHC	46.0	57.0	69.0	48.0	64.0	82.0	61.0	79.0	95.0
	kW	7.3	7.2	7.1	7.2	7.1	7.1	7.5	7.3	7.3
85	TC	101.0	86.0	79.0	107.0	96.0	85.0	111.0	100.0	90.0
	SHC	40.0	48.0	63.0	47.0	63.0	77.0	54.0	73.0	88.0
	kW	8.0	7.8	7.8	8.1	8.0	7.9	8.1	8.0	7.9
95	TC	93.0	82.0	73.0	99.0	88.0	78.0	103.0	92.0	84.0
	SHC	33.0	46.0	58.0	40.0	56.0	71.0	47.0	66.0	77.0
	kW	8.7	8.6	8.5	8.8	8.7	8.6	8.9	8.7	8.6
105	TC	85.0	75.0	66.0	90.0	80.0	71.0	94.0	83.0	75.0
	SHC	27.0	40.0	52.0	33.0	50.0	65.0	40.0	60.0	74.0
	kW	9.5	9.4	9.3	9.6	9.5	9.4	9.7	9.5	9.4
115	TC	77.0	68.0	59.0	81.0	72.0	63.0	85.0	75.0	69.0
	SHC	21.0	33.0	46.0	26.0	43.0	59.0	33.0	53.0	62.0
	kW	10.4	10.3	10.2	10.5	10.4	10.3	10.5	10.4	10.3
125	TC	69.0	60.0	51.0	73.0	64.0	56.0	75.0	66.0	60.0
	SHC	14.0	27.0	40.0	20.0	37.0	52.0	25.0	46.0	58.0
	kW	11.4	11.3	11.2	11.5	11.4	11.3	11.5	11.4	11.3

RGV/RAV102 — UNIT WITH HOT GAS RE-HEAT SYSTEM IN HOT GAS REHEAT MODE — COOLING CAPACITIES

TEMP (°F) AIR ENTERING CONDENSER (Edb)		AIR ENTERING EVAPORATOR — Ewb (°F)								
		75 Dry Bulb 62.5 Wet Bulb (50% Relative)			75 Dry Bulb 64 Wet Bulb (56% Relative)			75 Dry Bulb 65.3 Wet Bulb (60% Relative)		
		Air Entering Evaporator — cfm								
		2550	3400	4250	2550	3400	4250	2550	3400	4250
80	TC	36.0	39.0	41.0	37.0	40.0	430.0	38.0	42.0	44.0
	SHC	7.0	14.0	22.0	2.0	8.0	155.0	-2.0	3.0	9.0
	kW	6.2	6.2	6.2	6.3	6.3	6.2	6.3	6.3	6.3
75	TC	38.0	41.0	43.0	39.0	43.0	45.0	41.0	44.0	46.0
	SHC	8.0	16.0	24.0	4.0	11.0	17.0	0.0	6.0	12.0
	kW	5.4	5.4	5.4	5.4	5.5	5.5	5.6	5.6	5.7
70	TC	40.0	43.0	46.0	41.0	45.0	47.0	43.0	46.0	48.0
	SHC	10.0	18.0	26.0	6.0	13.0	19.0	2.0	8.0	14.0
	kW	5.2	5.2	5.2	5.2	5.2	5.2	5.2	5.2	5.2
60	TC	44.0	48.0	50.0	46.0	49.0	52.0	47.0	50.0	53.0
	SHC	14.0	22.0	30.0	9.0	16.0	23.0	5.0	11.0	17.0
	kW	5.2	5.1	5.1	5.1	5.1	5.1	5.1	5.1	5.1
50	TC	48.0	52.0	54.0	50.0	54.0	56.0	51.0	55.0	57.0
	SHC	17.0	26.0	34.0	13.0	20.0	27.0	9.0	15.0	21.0
	kW	5.1	5.1	5.1	5.1	5.1	5.1	5.1	5.1	5.1
40	TC	52.0	56.0	58.0	54.0	58.0	60.0	55.0	59.0	62.0
	SHC	21.0	30.0	38.0	16.0	24.0	31.0	12.0	19.0	25.0
	kW	5.1	5.1	5.1	5.1	5.1	5.1	5.1	5.1	5.0

LEGEND

- Edb** — Entering Dry Bulb
- Ewb** — Entering Wet Bulb
- kW** — Compressor Power Input
- SCFM/BF** — Standard Cubic Feet per Minute/Bypass Factor
- SHC** — Sensible Heat Capacity (1000 Btuh) Gross
- TC** — Total Capacity (1000 Btuh) Gross

Performance data (cont)

RGV/RAV120 TWO-STAGE COOLING CAPACITIES

RGV/RAV120			AMBIENT TEMPERATURE (°F)																
			85			95			105			115			125				
			EAT (db)			EAT (db)			EAT (db)			EAT (db)			EAT (db)				
			75	80	85	75	80	85	75	80	85	75	80	85	75	80	85		
3000 cfm	EAT (wb)	58	TC	109.6	109.6	124.0	104.5	104.5	118.3	99.2	99.2	112.4	93.2	93.2	105.7	87.0	87.0	98.9	
			SHC	95.3	109.6	124.0	90.7	104.5	118.3	86.0	99.2	112.4	80.7	93.2	105.7	75.2	87.0	98.9	
		62	TC	115.5	115.5	117.5	108.9	108.9	114.0	102.1	102.1	110.5	94.8	94.8	106.6	87.4	87.4	101.9	
			SHC	85.7	101.6	117.5	82.3	98.2	114.0	78.8	94.6	110.5	75.0	90.8	106.6	70.8	86.4	101.9	
		67	TC	126.7	126.7	126.7	120.0	120.0	120.0	112.6	112.6	112.6	104.8	104.8	104.8	96.6	96.6	96.6	
			SHC	69.4	85.2	101.0	66.2	82.0	97.8	62.7	78.6	94.4	59.1	75.0	90.9	55.4	71.3	87.2	
	72	TC	139.0	139.0	139.0	131.5	131.5	131.5	123.9	123.9	123.9	115.5	115.5	115.5	106.8	106.8	106.8		
		SHC	53.2	68.7	84.2	49.8	65.4	81.0	46.4	62.1	77.7	42.8	58.5	74.2	39.1	54.9	70.7		
	76	TC	—	149.4	149.4	—	141.9	141.9	—	133.5	133.5	—	124.7	124.7	—	115.4	115.4		
		SHC	—	55.1	71.6	—	52.0	66.0	—	48.7	63.4	—	45.2	60.3	—	41.6	57.0		
	3500 cfm	EAT (wb)	58	TC	115.9	115.9	130.9	110.5	110.5	125.0	104.6	104.6	118.4	98.3	98.3	111.5	91.7	91.7	104.1
				SHC	100.8	115.9	130.9	96.0	110.5	125.0	90.7	104.6	118.4	85.2	98.3	111.5	79.4	91.7	104.1
62			TC	119.0	119.0	129.3	112.4	112.4	125.7	105.3	105.3	121.3	98.8	98.8	114.9	91.9	91.9	108.4	
			SHC	92.8	111.0	129.3	89.3	107.5	125.7	85.3	103.3	121.3	80.4	97.6	114.9	75.3	91.9	108.4	
67			TC	130.5	130.5	130.5	123.1	123.1	123.1	115.7	115.7	115.7	107.5	107.5	107.5	98.9	98.9	98.9	
			SHC	74.2	92.6	110.9	70.8	89.2	107.6	67.4	85.8	104.2	63.8	82.2	100.6	60.0	78.5	96.9	
72		TC	142.9	142.9	142.9	135.1	135.1	135.1	127.1	127.1	127.1	118.4	118.4	118.4	109.2	109.2	109.2		
		SHC	55.3	73.4	91.5	51.9	70.1	88.2	48.5	66.7	84.9	44.8	63.1	81.4	41.1	59.4	77.8		
76		TC	—	153.8	153.8	—	145.5	145.5	—	136.8	136.8	—	127.6	127.6	—	118.0	118.0		
		SHC	—	57.9	74.8	—	54.7	71.9	—	51.3	68.8	—	47.7	65.6	—	44.1	62.1		
4000 cfm		EAT (wb)	58	TC	121.3	121.3	137.0	115.4	115.4	130.5	109.2	109.2	123.6	102.6	102.6	116.2	95.6	95.6	108.4
				SHC	105.5	121.3	137.0	100.3	115.4	130.5	94.8	109.2	123.6	88.9	102.6	116.2	82.7	95.6	108.4
	62		TC	122.0	122.0	139.7	117.0	117.0	132.7	111.8	111.8	120.7	102.7	102.7	120.9	95.7	95.7	112.8	
			SHC	99.0	119.3	139.7	94.0	113.4	132.7	86.4	103.5	120.7	84.5	102.7	120.9	78.5	95.7	112.8	
	67		TC	133.4	133.4	133.4	125.8	125.8	125.8	118.0	118.0	118.0	109.5	109.5	110.0	100.7	100.7	106.2	
			SHC	78.8	99.6	120.5	75.4	96.2	117.1	71.9	92.8	113.7	68.2	89.1	110.0	64.4	85.3	106.2	
	72	TC	145.9	145.9	145.9	138.0	138.0	138.0	129.5	129.5	129.5	120.5	120.5	120.5	111.1	111.1	111.1		
		SHC	57.3	77.9	98.5	53.9	74.6	95.3	50.4	71.1	91.9	46.7	67.5	88.3	43.0	63.8	84.6		
	76	TC	—	156.9	156.9	—	148.4	148.4	—	139.4	139.4	—	129.9	129.9	—	—	—		
		SHC	—	60.4	80.2	—	57.1	77.2	—	53.7	73.9	—	50.1	70.5	—	—	—		
	4500 cfm	EAT (wb)	58	TC	125.5	125.5	141.8	119.5	119.5	135.1	113.0	113.0	127.9	106.1	106.1	120.2	98.8	98.8	112.0
				SHC	109.3	125.5	141.8	103.9	119.5	135.1	98.2	113.0	127.9	92.0	106.1	120.2	85.5	98.8	112.0
62			TC	127.9	127.9	139.9	120.5	120.5	136.6	113.2	113.2	133.0	106.2	106.2	125.0	98.9	98.9	116.6	
			SHC	100.4	120.2	139.9	96.9	116.8	136.6	93.3	113.2	133.0	87.4	106.2	125.0	81.2	98.9	116.6	
67			TC	135.6	135.6	135.6	127.8	127.8	127.8	119.8	119.8	122.9	111.1	111.1	119.1	102.1	102.1	115.1	
			SHC	83.2	106.5	129.8	79.8	103.1	126.4	76.2	99.5	122.9	72.5	95.8	119.1	68.6	91.8	115.1	
72		TC	148.2	148.2	148.2	140.2	140.2	140.2	131.4	131.4	131.4	122.2	122.2	122.2	112.5	112.5	112.5		
		SHC	59.2	82.3	105.4	55.8	79.0	102.1	52.2	75.4	98.7	48.5	71.8	95.1	44.8	68.0	91.3		
76		TC	—	159.3	159.3	—	150.6	150.6	—	141.4	141.4	—	—	—	—	—	—		
		SHC	—	62.8	85.2	—	59.5	82.1	—	56.0	78.8	—	—	—	—	—	—		
5000 cfm		EAT (wb)	58	TC	129.3	129.3	146.0	123.1	123.1	139.1	116.3	116.3	131.5	109.1	109.1	123.5	101.5	101.5	115.1
				SHC	112.6	129.3	146.0	107.1	123.1	139.1	101.0	116.3	131.5	94.6	109.1	123.5	87.9	101.5	115.1
	62		TC	129.8	129.8	150.6	123.0	123.0	144.4	116.4	116.4	136.8	109.2	109.2	128.5	101.6	101.6	119.7	
			SHC	106.5	128.6	150.6	101.7	123.0	144.4	96.0	116.4	136.8	89.9	109.2	128.5	83.5	101.6	119.7	
	67		TC	137.8	137.8	139.0	129.4	129.4	135.4	121.3	121.3	131.7	112.4	112.4	127.6	103.3	103.3	123.2	
			SHC	87.5	113.3	139.0	83.9	109.6	135.4	80.3	106.0	131.7	76.5	102.0	127.6	72.4	97.8	123.2	
	72	TC	150.1	150.1	150.1	141.9	141.9	141.9	132.9	132.9	132.9	123.5	123.5	123.5	113.6	113.6	113.6		
		SHC	60.9	86.5	112.0	57.6	83.2	108.8	54.0	79.6	105.3	50.3	76.0	101.7	46.5	72.2	97.9		
	76	TC	—	161.4	161.4	—	152.4	152.4	—	—	—	—	—	—	—	—	—		
		SHC	—	65.1	90.1	—	61.7	86.8	—	—	—	—	—	—	—	—	—		

LEGEND

- Do Not Operate
- cfm — Cubic Feet Per Minute (Supply Air)
- EAT (db) — Entering Air Temperature (dry bulb)
- EAT (wb) — Entering Air Temperature (wet bulb)
- SHC — Sensible Heat Capacity (1000 Btuh) Gross
- TC — Total Capacity (1000 Btuh) Gross

NOTE: See minimum-maximum airflow ratings on page 6.

Performance data (cont)

RGV/RAV120 SINGLE-STAGE COOLING CAPACITIES

RGV/RAV120			AMBIENT TEMPERATURE (°F)																
			85			95			105			115			125				
			EAT (db)			EAT (db)			EAT (db)			EAT (db)			EAT (db)				
			75	80	85	75	80	85	75	80	85	75	80	85	75	80	85		
1800 cfm	EAT (wb)	58	TC	60.4	60.4	68.6	57.0	57.0	64.9	53.4	53.4	60.9	49.6	49.6	56.7	45.5	45.5	52.2	
			SHC	52.3	60.4	68.6	49.2	57.0	64.9	45.9	53.4	60.9	42.4	49.6	56.7	38.8	45.5	52.2	
		62	TC	62.7	62.7	67.1	58.5	58.5	64.6	54.2	54.2	62.1	50.1	50.1	57.9	45.6	45.6	54.6	
			SHC	47.8	57.5	67.1	45.3	55.0	64.6	42.8	52.5	62.1	39.5	48.7	57.9	36.6	45.6	54.6	
		67	TC	69.4	69.4	69.4	65.1	65.1	65.1	60.5	60.5	60.5	55.5	55.5	55.5	50.4	50.4	50.4	
			SHC	38.6	48.2	57.8	36.2	45.8	55.4	33.7	43.4	53.0	31.2	40.8	50.5	28.5	38.2	47.9	
	72	TC	76.8	76.8	76.8	72.2	72.2	72.2	67.4	67.4	67.4	62.1	62.1	62.1	56.6	56.6	56.6		
		SHC	29.2	38.7	48.3	26.9	36.4	46.0	24.4	34.0	43.6	21.9	31.5	41.1	19.3	28.9	38.5		
	76	TC	—	83.1	83.1	—	78.3	78.3	—	—	—	—	—	—	—	—	—		
		SHC	—	31.1	40.1	—	28.8	38.0	—	—	—	—	—	—	—	—	—		
	2100 cfm	EAT (wb)	58	TC	64.2	64.2	72.8	60.5	60.5	68.8	56.7	56.7	64.6	52.6	52.6	60.1	48.3	48.3	55.4
				SHC	55.6	64.2	72.8	52.3	60.5	68.8	48.8	56.7	64.6	45.1	52.6	60.1	41.3	48.3	55.4
62			TC	64.8	64.8	74.2	60.7	60.7	71.2	56.8	56.8	67.3	52.7	52.7	62.8	48.4	48.4	57.8	
			SHC	52.1	63.2	74.2	49.4	60.3	71.2	46.2	56.8	67.3	42.7	52.7	62.8	39.0	48.4	57.8	
67			TC	71.6	71.6	71.6	67.1	67.1	67.1	62.3	62.3	62.3	57.1	57.1	57.1	51.7	51.7	53.9	
			SHC	41.5	52.7	63.9	39.1	50.4	61.6	36.6	47.8	59.1	34.0	45.2	56.5	31.4	42.6	53.9	
72		TC	79.0	79.0	79.0	74.3	74.3	74.3	69.2	69.2	69.2	63.8	63.8	63.8	58.1	58.1	58.1		
		SHC	30.6	41.7	52.8	28.2	39.4	50.5	25.8	36.9	48.1	23.2	34.3	45.5	20.5	31.7	42.9		
76		TC	—	—	—	—	—	—	—	—	—	—	—	—	—	—	—		
		SHC	—	—	—	—	—	—	—	—	—	—	—	—	—	—	—		
2400 cfm		EAT (wb)	58	TC	67.2	67.2	76.1	63.5	63.5	72.1	59.5	59.5	67.7	55.2	55.2	63.0	50.6	50.6	57.9
				SHC	58.2	67.2	76.1	54.9	63.5	72.1	51.3	59.5	67.7	47.4	55.2	63.0	43.3	50.6	57.9
	62		TC	67.3	67.3	79.2	63.6	63.6	75.0	59.6	59.6	70.5	55.2	55.2	65.6	50.7	50.7	60.5	
			SHC	55.3	67.2	79.2	52.1	63.5	75.0	48.6	59.6	70.5	44.8	55.2	65.6	40.9	50.7	60.5	
	67		TC	73.2	73.2	73.2	68.6	68.6	68.6	63.6	63.6	65.0	58.3	58.3	62.3	52.8	52.8	59.6	
			SHC	44.4	57.1	69.9	42.0	54.7	67.5	39.4	52.2	65.0	36.8	49.6	62.3	34.1	46.8	59.6	
	72	TC	80.7	80.7	80.7	75.9	75.9	75.9	70.6	70.6	70.6	65.0	65.0	65.0	59.1	59.1	59.1		
		SHC	31.9	44.6	57.2	29.5	42.2	54.9	27.0	39.7	52.4	24.4	37.1	49.9	21.7	34.5	47.2		
	76	TC	—	—	—	—	—	—	—	—	—	—	—	—	—	—	—		
		SHC	—	—	—	—	—	—	—	—	—	—	—	—	—	—	—		
	2700 cfm	EAT (wb)	58	TC	69.9	69.9	79.2	65.9	65.9	74.8	61.8	61.8	70.3	57.3	57.3	65.3	52.6	52.6	60.1
				SHC	60.6	69.9	79.2	57.0	65.9	74.8	53.3	61.8	70.3	49.3	57.3	65.3	45.0	52.6	60.1
62			TC	69.9	69.9	82.2	66.0	66.0	77.8	61.8	61.8	73.1	57.3	57.3	68.0	52.6	52.6	62.7	
			SHC	57.5	69.9	82.2	54.1	66.0	77.8	50.5	61.8	73.1	46.6	57.3	68.0	42.5	52.6	62.7	
67			TC	74.5	74.5	75.7	69.8	69.8	73.3	64.7	64.7	70.6	59.2	59.2	67.8	53.6	53.6	64.9	
			SHC	47.1	61.4	75.7	44.7	59.0	73.3	42.1	56.4	70.6	39.4	53.6	67.8	36.6	50.8	64.9	
72		TC	82.1	82.1	82.1	77.1	77.1	77.1	71.7	71.7	71.7	65.9	65.9	65.9	—	—	—		
		SHC	33.1	47.3	61.5	30.7	44.9	59.1	28.1	42.4	56.7	25.5	39.8	54.1	—	—	—		
76		TC	—	—	—	—	—	—	—	—	—	—	—	—	—	—	—		
		SHC	—	—	—	—	—	—	—	—	—	—	—	—	—	—	—		
3000 cfm		EAT (wb)	58	TC	72.1	72.1	81.6	68.0	68.0	77.1	63.7	63.7	72.4	59.1	59.1	67.4	54.2	54.2	61.9
				SHC	62.6	72.1	81.6	58.9	68.0	77.1	55.0	63.7	72.4	50.9	59.1	67.4	46.5	54.2	61.9
	62		TC	72.1	72.1	84.8	68.1	68.1	80.3	63.8	63.8	75.4	59.1	59.1	70.1	54.3	54.3	64.6	
			SHC	59.4	72.1	84.8	55.9	68.1	80.3	52.1	63.8	75.4	48.1	59.1	70.1	43.9	54.3	64.6	
	67		TC	75.5	75.5	81.2	70.7	70.7	78.7	65.5	65.5	75.9	60.0	60.0	73.0	54.5	54.5	69.1	
			SHC	49.7	65.5	81.2	47.2	63.0	78.7	44.5	60.2	75.9	41.8	57.4	73.0	38.6	53.9	69.1	
	72	TC	83.1	83.1	83.1	78.0	78.0	78.0	—	—	—	—	—	—	—	—	—		
		SHC	34.2	50.0	65.7	31.8	47.6	63.3	—	—	—	—	—	—	—	—	—		
	76	TC	—	—	—	—	—	—	—	—	—	—	—	—	—	—	—		
		SHC	—	—	—	—	—	—	—	—	—	—	—	—	—	—	—		

LEGEND

- Do Not Operate
- cfm — Cubic Feet Per Minute (Supply Air)
- EAT (db) — Entering Air Temperature (dry bulb)
- EAT (wb) — Entering Air Temperature (wet bulb)
- SHC — Sensible Heat Capacity (1000 Btuh) Gross
- TC — Total Capacity (1000 Btuh) Gross

NOTE: See minimum-maximum airflow ratings on page 6.

Performance data (cont)

RGV/RAV120 — UNIT WITH HOT GAS RE-HEAT SYSTEM IN SUBCOOLING MODE — COOLING CAPACITIES

TEMP (°F) AIR ENTERING CONDENSER (Edb)		AIR ENTERING EVAPORATOR — SCFM/BF (80°F db)								
		3000/0.06			4000/0.08			5000/0.10		
		Air Entering Evaporator — Ewb (°F)								
		72	67	62	72	67	62	72	67	62
75	TC	137.0	124.0	111.0	147.0	132.0	120.0	147.0	135.0	129.0
	SHC	58.0	78.0	97.0	72.0	96.0	117.0	78.0	110.0	125.0
	kW	9.6	9.4	9.2	9.8	9.6	9.4	9.8	9.7	9.6
85	TC	128.0	116.0	103.0	135.0	123.0	112.0	140.0	127.0	118.0
	SHC	51.0	72.0	89.0	61.0	88.0	109.0	72.0	104.0	118.0
	kW	10.4	10.3	10.0	10.6	10.4	10.2	10.7	10.5	10.3
95	TC	117.0	107.0	96.0	124.0	111.0	101.0	128.0	117.0	110.0
	SHC	41.0	63.0	83.0	52.0	77.0	98.0	62.0	95.0	110.0
	kW	11.3	11.1	10.9	11.4	11.2	11.0	11.5	11.3	11.2
105	TC	110.0	98.0	87.0	117.0	104.0	95.0	120.0	104.0	99.0
	SHC	35.0	55.0	76.0	46.0	72.0	89.0	55.0	83.0	99.0
	kW	12.3	12.1	11.9	12.5	12.2	12.0	12.6	12.2	12.2
115	TC	101.0	89.0	78.0	106.0	92.0	84.0	109.0	96.0	92.0
	SHC	28.0	48.0	68.0	37.0	61.0	82.0	46.0	77.0	92.0
	kW	13.4	13.2	13.0	13.6	13.3	13.1	13.6	13.4	13.3
125	TC	92.0	79.0	69.0	95.0	81.0	75.0	98.0	87.0	81.0
	SHC	20.0	39.0	60.0	28.0	52.0	74.0	37.0	69.0	81.0
	kW	14.7	14.4	14.2	14.8	14.4	14.3	14.8	14.6	14.5

RGV/RAV120 — UNIT WITH HOT GAS RE-HEAT SYSTEM IN HOT GAS REHEAT MODE — COOLING CAPACITIES

TEMP (°F) AIR ENTERING CONDENSER (Edb)		AIR ENTERING EVAPORATOR — Ewb (°F)								
		75 Dry Bulb 62.5 Wet Bulb (50% Relative)			75 Dry Bulb 64 Wet Bulb (56% Relative)			75 Dry Bulb 65.3 Wet Bulb (60% Relative)		
		Air Entering Evaporator — cfm								
		3000	4000	5000	3000	4000	5000	3000	4000	5000
80	TC	45.0	49.0	52.0	46.0	51.0	53.0	48.0	52.0	54.0
	SHC	7.0	16.0	25.0	2.0	9.0	17.0	-3.0	4.0	10.0
	kW	7.4	7.6	7.7	7.6	7.7	7.7	7.7	7.8	7.8
75	TC	47.0	52.0	54.0	49.0	53.0	56.0	50.0	54.0	57.0
	SHC	9.0	18.0	28.0	4.0	12.0	20.0	0.0	7.0	14.0
	kW	6.8	6.9	6.9	6.9	6.9	7.0	7.0	7.1	7.1
70	TC	50.0	54.0	57.0	51.0	56.0	59.0	53.0	57.0	60.0
	SHC	11.0	20.0	30.0	5.0	14.0	22.0	2.0	8.0	15.0
	kW	6.7	6.7	6.7	6.7	6.7	6.7	6.7	6.8	6.8
60	TC	54.0	59.0	62.0	56.0	61.0	64.0	58.0	62.0	65.0
	SHC	15.0	25.0	35.0	9.0	18.0	26.0	5.0	12.0	19.0
	kW	6.6	6.6	6.7	6.6	6.7	6.7	6.7	6.7	6.7
50	TC	59.0	64.0	67.0	61.0	66.0	69.0	63.0	68.0	71.0
	SHC	19.0	29.0	39.0	13.0	22.0	31.0	9.0	16.0	24.0
	kW	6.6	6.6	6.6	6.6	6.6	6.6	6.6	6.6	6.6
40	TC	63.0	69.0	72.0	66.0	71.0	74.0	67.0	73.0	76.0
	SHC	23.0	33.0	44.0	17.0	26.0	35.0	13.0	20.0	28.0
	kW	6.6	6.6	6.6	6.6	6.6	6.6	6.6	6.6	6.6

LEGEND

- Edb** — Entering Dry Bulb
- Ewb** — Entering Wet Bulb
- kW** — Compressor Power Input
- SCFM/BF** — Standard Cubic Feet per Minute/Bypass Factor
- SHC** — Sensible Heat Capacity (1000 Btuh) Gross
- TC** — Total Capacity (1000 Btuh) Gross

Performance data (cont)

RGV/RAV150 TWO-STAGE COOLING CAPACITIES

RGV/RAV150			AMBIENT TEMPERATURE (°F)													
			85			95			105			115				
			EAT (db)			EAT (db)			EAT (db)			EAT (db)				
			75	80	85	75	80	85	75	80	85	75	80	85		
3750 cfm	EAT (wb)	58	TC	126.4	126.4	144.1	118.4	118.4	135.4	109.9	109.9	126.2	101.1	101.1	116.6	
			SHC	108.8	126.4	144.1	101.4	118.4	135.4	93.6	109.9	126.2	85.5	101.1	116.6	
		62	TC	134.1	134.1	136.3	124.3	124.3	130.2	114.1	114.1	123.8	103.6	103.6	117.3	
			SHC	97.3	116.8	136.3	91.1	110.7	130.2	84.8	104.3	123.8	78.4	97.9	117.3	
		67	TC	149.5	149.5	149.5	139.3	139.3	139.3	128.6	128.6	128.6	117.4	117.4	117.4	
			SHC	78.5	97.9	117.3	72.4	91.9	111.3	66.1	85.6	105.1	59.8	79.3	98.8	
	72	TC	166.4	166.4	166.4	155.6	155.6	155.6	144.2	144.2	144.2	132.5	132.5	132.5		
		SHC	59.7	78.7	97.8	53.6	72.8	91.9	47.3	66.5	85.7	40.9	60.2	79.5		
	76	TC	—	181.4	181.4	—	169.7	169.7	—	157.7	157.7	—	145.4	145.4		
		SHC	—	63.0	83.4	—	57.1	77.5	—	51.0	68.5	—	44.7	63.1		
	4400 cfm	EAT (wb)	58	TC	135.2	135.2	153.9	126.7	126.7	144.7	117.8	117.8	135.0	108.4	108.4	124.8
				SHC	116.6	135.2	153.9	108.8	126.7	144.7	100.6	117.8	135.0	92.1	108.4	124.8
62			TC	139.3	139.3	152.1	129.4	129.4	145.7	119.0	119.0	138.8	110.0	110.0	127.5	
			SHC	106.8	129.5	152.1	100.6	123.2	145.7	94.1	116.4	138.8	85.3	106.4	127.5	
67			TC	154.8	154.8	154.8	144.1	144.1	144.1	133.1	133.1	133.1	121.5	121.5	121.5	
			SHC	84.4	107.1	129.8	78.3	101.0	123.7	72.0	94.7	117.4	65.5	88.3	111.0	
72		TC	171.9	171.9	171.9	160.5	160.5	160.5	148.7	148.7	148.7	136.5	136.5	136.5		
		SHC	61.9	84.2	106.5	55.6	78.0	100.4	49.2	71.7	94.1	42.8	65.2	87.7		
76		TC	—	186.5	186.5	—	174.5	174.5	—	162.3	162.3	—	149.4	149.4		
		SHC	—	65.6	86.0	—	59.5	80.6	—	53.3	74.7	—	46.8	68.6		
5000 cfm		EAT (wb)	58	TC	142.1	142.1	161.5	133.2	133.2	151.9	123.8	123.8	141.8	114.2	114.2	131.2
				SHC	122.7	142.1	161.5	114.5	133.2	151.9	106.0	123.8	141.8	97.2	114.2	131.2
	62		TC	143.6	143.6	165.3	136.2	136.2	151.7	125.8	125.8	143.6	114.2	114.2	137.0	
			SHC	114.9	140.2	165.3	105.3	128.5	151.7	98.2	120.9	143.6	91.6	114.2	137.0	
	67		TC	158.6	158.6	158.6	147.6	147.6	147.6	136.1	136.1	136.1	124.3	124.3	124.3	
			SHC	89.6	115.2	140.8	83.4	109.0	134.5	77.1	102.7	128.3	70.7	96.2	121.9	
	72	TC	175.7	175.7	175.7	163.9	163.9	163.9	151.9	151.9	151.9	139.4	139.4	139.4		
		SHC	63.4	88.6	113.9	57.1	82.4	107.7	50.7	76.0	101.4	44.2	69.5	94.9		
	76	TC	—	190.4	190.4	—	178.0	178.0	—	165.2	165.2	—	152.1	152.1		
		SHC	—	67.3	91.3	—	61.1	85.4	—	54.6	79.3	—	48.1	72.9		
	5650 cfm	EAT (wb)	58	TC	148.3	148.3	168.4	139.1	139.1	158.4	129.4	129.4	147.9	119.3	119.3	136.8
				SHC	128.2	148.3	168.4	119.8	139.1	158.4	111.0	129.4	147.9	101.8	119.3	136.8
62			TC	153.3	153.3	164.2	143.1	143.1	156.2	129.6	129.6	154.2	119.5	119.5	143.0	
			SHC	116.4	140.3	164.2	109.3	132.8	156.2	104.9	129.6	154.2	96.0	119.5	143.0	
67			TC	161.9	161.9	161.9	150.6	150.6	150.6	138.9	138.9	139.8	126.7	126.7	133.3	
			SHC	94.9	123.7	152.3	88.8	117.4	146.1	82.5	111.1	139.8	76.0	104.6	133.3	
72		TC	178.9	178.9	178.9	166.9	166.9	166.9	154.6	154.6	154.6	141.9	141.9	141.9		
		SHC	64.6	93.0	121.4	58.3	86.6	115.0	51.8	80.3	108.7	45.2	73.8	102.2		
76		TC	—	193.6	193.6	—	180.9	180.9	—	167.9	167.9	—	—	—		
		SHC	—	68.5	95.9	—	62.2	89.7	—	55.6	83.4	—	—	—		
6250 cfm		EAT (wb)	58	TC	153.3	153.3	173.9	143.7	143.7	163.5	133.7	133.7	152.7	123.4	123.4	141.4
				SHC	132.7	153.3	173.9	123.8	143.7	163.5	114.8	133.7	152.7	105.3	123.4	141.4
	62		TC	154.5	154.5	177.7	143.9	143.9	170.4	133.9	133.9	159.3	123.6	123.6	147.6	
			SHC	124.2	151.0	177.7	117.4	143.9	170.4	108.6	133.9	159.3	99.5	123.6	147.6	
	67		TC	164.3	164.3	164.3	153.0	153.0	156.4	140.9	140.9	150.0	128.7	128.7	143.6	
			SHC	99.8	131.2	162.7	93.6	125.0	156.4	87.3	118.6	150.0	81.0	112.3	143.6	
	72	TC	181.5	181.5	181.5	169.3	169.3	169.3	156.7	156.7	156.7	143.7	143.7	143.7		
		SHC	65.4	96.6	127.7	59.0	90.3	121.5	52.6	83.9	115.0	46.0	77.3	108.6		
	76	TC	—	196.0	196.0	—	183.1	183.1	—	169.9	169.9	—	—	—		
		SHC	—	69.0	99.3	—	62.5	93.0	—	55.8	86.4	—	—	—		

LEGEND

- Do Not Operate
- cfm — Cubic Feet Per Minute (Supply Air)
- EAT (db) — Entering Air Temperature (dry bulb)
- EAT (wb) — Entering Air Temperature (wet bulb)
- SHC — Sensible Heat Capacity (1000 Btuh) Gross
- TC — Total Capacity (1000 Btuh) Gross

NOTE: See minimum-maximum airflow ratings on page 6.

Performance data (cont)

RGV/RAV150 SINGLE-STAGE COOLING CAPACITIES

RGV/RAV150				AMBIENT TEMPERATURE (°F)												
				85			95			105			115			
				EAT (db)			EAT (db)			EAT (db)			EAT (db)			
				75	80	85	75	80	85	75	80	85	75	80	85	
2050 cfm	EAT (wb)	58	TC	73.0	73.0	83.0	69.0	69.0	78.6	64.9	64.9	74.1	60.6	60.6	69.3	
			SHC	63.1	73.0	83.0	59.5	69.0	78.6	55.7	64.9	74.1	51.8	60.6	69.3	
		62	TC	77.1	77.1	78.9	72.3	72.3	76.0	67.1	67.1	73.0	61.9	61.9	69.9	
			SHC	56.8	67.9	78.9	54.0	64.9	76.0	51.0	62.0	73.0	47.9	58.9	69.9	
		67	TC	85.8	85.8	85.8	80.6	80.6	80.6	75.1	75.1	75.1	69.4	69.4	69.4	
			SHC	46.5	57.6	68.6	43.7	54.6	65.7	40.7	51.7	62.8	37.6	48.7	59.7	
	72	TC	95.3	95.3	95.3	89.7	89.7	89.7	84.0	84.0	84.0	77.8	77.8	77.8		
		SHC	36.0	47.1	58.3	33.2	44.3	55.3	30.2	41.3	52.4	27.1	38.3	49.4		
	76	TC	—	103.5	103.5	—	97.5	97.5	—	91.4	91.4	—	—	—		
		SHC	—	38.5	49.7	—	35.6	46.8	—	32.8	43.9	—	—	—		
	2500 cfm	EAT (wb)	58	TC	79.3	79.3	89.9	74.9	74.9	85.2	70.5	70.5	80.3	65.7	65.7	75.0
				SHC	68.6	79.3	89.9	64.7	74.9	85.2	60.6	70.5	80.3	56.3	65.7	75.0
62			TC	80.9	80.9	90.4	75.7	75.7	87.2	71.1	71.1	82.4	65.8	65.8	78.3	
			SHC	63.8	77.1	90.4	60.7	74.0	87.2	56.8	69.6	82.4	53.3	65.8	78.3	
67			TC	89.6	89.6	89.6	84.1	84.1	84.1	78.2	78.2	78.2	72.2	72.2	72.2	
			SHC	51.0	64.4	77.8	48.0	61.5	74.8	45.0	58.4	71.9	41.9	55.3	68.7	
72		TC	99.3	99.3	99.3	93.4	93.4	93.4	87.1	87.1	87.1	80.7	80.7	80.7		
		SHC	37.9	51.5	64.9	35.0	48.5	62.0	32.0	45.4	58.9	28.9	42.4	55.8		
76		TC	—	107.4	107.4	—	—	—	—	—	—	—	—	—		
		SHC	—	40.9	54.5	—	—	—	—	—	—	—	—	—		
2900 cfm		EAT (wb)	58	TC	83.8	83.8	94.9	79.2	79.2	89.9	74.3	74.3	84.6	69.4	69.4	79.2
				SHC	72.6	83.8	94.9	68.4	79.2	89.9	64.2	74.3	84.6	59.6	69.4	79.2
	62		TC	83.9	83.9	98.8	78.7	78.7	93.3	74.4	74.4	88.2	69.5	69.5	82.6	
			SHC	68.9	83.9	98.8	64.2	78.7	93.3	60.8	74.4	88.2	56.4	69.5	82.6	
	67		TC	92.0	92.0	92.0	86.2	86.2	86.2	80.2	80.2	80.2	74.1	74.1	76.4	
			SHC	54.7	70.2	85.7	51.7	67.2	82.7	48.6	64.2	79.6	45.5	61.0	76.4	
	72	TC	101.8	101.8	101.8	95.6	95.6	95.6	89.2	89.2	89.2	82.6	82.6	82.6		
		SHC	39.4	54.9	70.6	36.4	52.0	67.5	33.4	48.9	64.4	30.2	45.7	61.3		
	76	TC	—	—	—	—	—	—	—	—	—	—	—	—		
		SHC	—	—	—	—	—	—	—	—	—	—	—	—		
	3300 cfm	EAT (wb)	58	TC	87.5	87.5	99.1	82.7	82.7	93.9	77.7	77.7	88.3	72.5	72.5	82.6
				SHC	75.9	87.5	99.1	71.6	82.7	93.9	67.0	77.7	88.3	62.3	72.5	82.6
62			TC	87.6	87.6	103.2	82.8	82.8	97.7	77.8	77.8	92.0	72.5	72.5	86.0	
			SHC	72.1	87.6	103.2	67.9	82.8	97.7	63.6	77.8	92.0	59.0	72.5	86.0	
67			TC	93.9	93.9	93.9	87.9	87.9	90.2	81.8	81.8	87.1	75.4	75.4	83.9	
			SHC	58.2	75.7	93.3	55.2	72.8	90.2	52.2	69.6	87.1	49.0	66.4	83.9	
72		TC	103.8	103.8	103.8	97.3	97.3	97.3	90.8	90.8	90.8	84.0	84.0	84.0		
		SHC	40.7	58.3	75.9	37.6	55.2	72.9	34.6	52.2	69.7	31.4	49.0	66.5		
76		TC	—	—	—	—	—	—	—	—	—	—	—	—		
		SHC	—	—	—	—	—	—	—	—	—	—	—	—		
3700 cfm		EAT (wb)	58	TC	90.7	90.7	102.7	85.7	85.7	97.2	80.5	80.5	91.5	75.0	75.0	85.4
				SHC	78.7	90.7	102.7	74.3	85.7	97.2	69.5	80.5	91.5	64.5	75.0	85.4
	62		TC	90.8	90.8	106.8	85.8	85.8	101.2	80.6	80.6	95.2	75.1	75.1	89.0	
			SHC	74.8	90.8	106.8	70.5	85.8	101.2	65.9	80.6	95.2	61.2	75.1	89.0	
	67		TC	95.3	95.3	100.7	89.3	89.3	97.6	83.1	83.1	94.3	76.6	76.6	91.0	
			SHC	61.7	81.2	100.7	58.6	78.1	97.6	55.5	74.9	94.3	52.4	71.7	91.0	
	72	TC	105.2	105.2	105.2	98.7	98.7	98.7	92.0	92.0	92.0	—	—	—		
		SHC	41.8	61.4	81.1	38.7	58.3	77.9	35.6	55.2	74.8	—	—	—		
	76	TC	—	—	—	—	—	—	—	—	—	—	—	—		
		SHC	—	—	—	—	—	—	—	—	—	—	—	—		

LEGEND

- Do Not Operate
- cfm — Cubic Feet Per Minute (Supply Air)
- EAT (db) — Entering Air Temperature (dry bulb)
- EAT (wb) — Entering Air Temperature (wet bulb)
- SHC — Sensible Heat Capacity (1000 Btuh) Gross
- TC — Total Capacity (1000 Btuh) Gross

NOTE: See minimum-maximum airflow ratings on page 6.

Performance data (cont)

RGV/RAV150 — UNIT WITH HOT GAS RE-HEAT SYSTEM IN SUBCOOLING MODE — COOLING CAPACITIES

TEMP (°F) AIR ENTERING CONDENSER (Edb)		AIR ENTERING EVAPORATOR — SCFM/BF (80°F db)								
		3750/0.11			5000/0.13			6250/0.15		
		Air Entering Evaporator — Ewb (°F)								
		72	67	62	72	67	62	72	67	62
75	TC	157.0	140.0	127.0	165.0	150.0	135.0	172.0	156.0	141.0
	SHC	64.0	82.0	101.0	74.0	99.0	122.0	85.0	114.0	138.0
	kW	12.4	12.0	11.8	12.6	12.3	12.0	12.8	12.4	12.1
85	TC	137.0	132.0	118.0	144.0	141.0	127.0	151.0	132.0	133.0
	SHC	46.0	75.0	93.0	55.0	91.0	114.0	66.0	92.0	129.0
	kW	13.0	13.1	12.8	13.2	13.4	13.0	13.4	12.9	13.2
95	TC	137.0	122.0	110.0	145.0	129.0	117.0	150.0	134.0	123.0
	SHC	47.0	66.0	86.0	57.0	80.0	105.0	66.0	95.0	120.0
	kW	14.7	14.3	14.0	14.9	14.5	14.2	15.0	14.6	14.3
105	TC	127.0	113.0	103.0	134.0	120.0	108.0	139.0	125.0	114.0
	SHC	39.0	58.0	74.0	48.0	73.0	97.0	56.0	86.0	110.0
	kW	15.9	15.6	15.3	16.1	15.8	15.5	16.3	15.9	15.6
115	TC	116.0	103.0	94.0	123.0	110.0	98.0	127.0	114.0	103.0
	SHC	29.0	50.0	66.0	38.0	64.0	89.0	46.0	76.0	102.0
	kW	17.3	16.9	11.7	17.5	17.1	16.8	17.6	17.2	16.9

RGV/RAV150 — UNIT WITH HOT GAS RE-HEAT SYSTEM IN HOT GAS REHEAT MODE — COOLING CAPACITIES

TEMP (°F) AIR ENTERING CONDENSER (Edb)		AIR ENTERING EVAPORATOR — Ewb (°F)								
		75 Dry Bulb 62.5 Wet Bulb (50% Relative)			75 Dry Bulb 64 Wet Bulb (56% Relative)			75 Dry Bulb 65.3 Wet Bulb (60% Relative)		
		Air Entering Evaporator — cfm								
		3750	5000	6250	3750	5000	6250	3750	5000	6250
80	TC	54.0	59.0	62.0	56.0	61.0	64.0	58.0	63.0	66.0
	SHC	9.0	20.0	31.0	3.0	12.0	21.0	-3.0	5.0	13.0
	kW	10.9	11.0	11.1	11.0	11.1	11.1	11.0	11.1	11.2
75	TC	57.0	62.0	65.0	60.0	65.0	68.0	62.0	67.0	70.0
	SHC	13.0	24.0	35.0	7.0	16.0	25.0	2.0	9.0	17.0
	kW	10.5	10.6	10.6	10.6	10.6	10.7	10.6	10.7	10.8
70	TC	61.0	66.0	69.0	63.0	68.0	72.0	66.0	71.0	74.0
	SHC	17.0	28.0	39.0	12.0	21.0	30.0	7.0	15.0	22.0
	kW	10.1	10.2	10.3	10.2	10.3	10.3	10.2	10.3	10.4
60	TC	62.0	67.0	70.0	64.0	69.0	72.0	66.0	71.0	74.0
	SHC	16.0	27.0	38.0	10.0	19.0	28.0	4.0	12.0	20.0
	kW	11.0	11.3	11.5	11.1	11.4	11.6	11.3	11.5	11.7
50	TC	69.0	74.0	77.0	71.0	76.0	80.0	73.0	79.0	82.0
	SHC	23.0	34.0	45.0	17.0	26.0	35.0	11.0	19.0	27.0
	kW	10.2	10.4	10.6	10.3	10.5	10.7	10.4	10.7	10.8
40	TC	75.0	80.0	84.0	78.0	83.0	87.0	80.0	86.0	89.0
	SHC	31.0	41.0	52.0	25.0	34.0	43.0	19.0	27.0	35.0
	kW	9.4	9.7	9.8	9.6	9.8	10.0	9.7	9.9	10.1

LEGEND

- Ewb** — Entering wet bulb
- kW** — compressor Power Input
- SCFM/BF** — Standard Cubic Feet per Minute/Bypass Factor
- SHC** — Sensible Heat Capacity (1000 Btuh) Gross
- TC** — Total Capacity (1000 Btuh) Gross

NOTE: See minimum-maximum airflow ratings on page 6.

Performance data (cont)

RGV/RAV180 TWO-STAGE COOLING CAPACITIES

RGV/RAV180				AMBIENT TEMPERATURE (°F)												
				85			95			105			115			
				EAT (db)			EAT (db)			EAT (db)			EAT (db)			
				75	80	85	75	80	85	75	80	85	75	80	85	
4500 cfm	EAT (wb)	58	TC	159.2	159.2	175.8	148.5	148.5	169.0	139.2	139.2	158.8	129.5	129.5	148.1	
			SHC	134.9	155.4	175.8	128.1	148.5	169.0	119.6	139.2	158.8	110.8	129.5	148.1	
		62	TC	167.4	167.4	167.7	156.4	156.4	161.3	145.1	145.1	154.6	133.1	133.1	147.5	
			SHC	121.7	144.7	167.7	115.2	138.2	161.3	108.5	131.5	154.6	101.6	124.5	147.5	
		67	TC	185.3	185.3	185.3	173.6	173.6	173.6	161.4	161.4	161.4	148.7	148.7	148.7	
			SHC	99.0	121.9	144.7	92.5	115.4	138.3	85.9	108.9	131.8	79.1	102.1	125.1	
	72	TC	205.2	205.2	205.2	192.5	192.5	192.5	179.4	179.4	179.4	165.9	165.9	165.9		
		SHC	76.7	98.8	120.9	70.0	92.3	114.7	63.3	85.8	108.3	56.5	79.1	101.8		
	76	TC	—	223.0	223.0	—	209.2	209.2	—	195.2	195.2	—	180.9	180.9		
		SHC	—	78.7	103.5	—	73.1	97.8	—	66.9	84.3	—	60.4	81.0		
	5250 cfm	EAT (wb)	58	TC	167.2	167.2	189.6	157.7	157.7	179.2	147.8	147.8	168.4	137.4	137.4	157.0
				SHC	144.8	167.2	189.6	136.2	157.7	179.2	127.2	147.8	168.4	117.8	137.4	157.0
62			TC	173.3	173.3	185.3	161.8	161.8	178.3	150.0	150.0	171.1	138.5	138.5	162.1	
			SHC	132.4	158.8	185.3	125.5	151.9	178.3	118.6	144.8	171.1	110.7	136.4	162.1	
67			TC	191.2	191.2	191.2	178.9	178.9	178.9	166.2	166.2	166.2	153.0	153.0	153.0	
			SHC	106.2	132.6	159.0	99.6	126.0	152.5	92.8	119.3	145.8	85.9	112.5	139.0	
72		TC	211.1	211.1	211.1	197.9	197.9	197.9	184.3	184.3	184.3	170.3	170.3	170.3		
		SHC	79.9	105.8	131.6	73.2	99.2	125.3	66.4	92.6	118.7	59.6	85.8	112.1		
76		TC	—	228.5	228.5	—	214.6	214.6	—	200.1	200.1	—	185.3	185.3		
		SHC	—	83.8	112.7	—	77.5	100.7	—	70.9	95.2	—	64.3	89.4		
6000 cfm		EAT (wb)	58	TC	175.3	175.3	198.7	165.4	165.4	187.8	154.9	154.9	176.4	144.1	144.1	164.4
				SHC	152.0	175.3	198.7	143.0	165.4	187.8	133.5	154.9	176.4	123.7	144.1	164.4
	62		TC	178.0	178.0	201.2	166.7	166.7	193.0	157.0	157.0	179.3	147.0	147.0	165.2	
			SHC	142.0	171.6	201.2	134.6	163.8	193.0	124.6	152.0	179.3	114.3	139.8	165.2	
	67		TC	195.7	195.7	195.7	183.1	183.1	183.1	169.9	169.9	169.9	156.3	156.3	156.3	
			SHC	112.8	142.7	172.7	106.1	136.1	166.0	99.3	129.3	159.2	92.4	122.3	152.3	
	72	TC	215.7	215.7	215.7	202.1	202.1	202.1	188.1	188.1	188.1	173.6	173.6	173.6		
		SHC	82.9	112.4	141.8	76.2	105.8	135.3	69.4	99.0	128.7	62.5	92.2	122.0		
	76	TC	—	233.3	233.3	—	218.9	218.9	—	203.9	203.9	—	188.5	188.5		
		SHC	—	87.8	114.8	—	81.3	109.1	—	74.7	103.1	—	67.9	96.7		
	6750 cfm	EAT (wb)	58	TC	182.2	182.2	206.3	171.8	171.8	194.9	160.9	160.9	183.0	149.5	149.5	170.5
				SHC	158.1	182.2	206.3	148.7	171.8	194.9	138.8	160.9	183.0	128.6	149.5	170.5
62			TC	183.3	183.3	212.5	172.6	172.6	200.6	162.9	162.9	185.9	149.8	149.8	177.8	
			SHC	149.2	180.9	212.5	140.0	170.3	200.6	129.5	157.7	185.9	121.7	149.8	177.8	
67			TC	199.4	199.4	199.4	186.3	186.3	186.3	172.8	172.8	172.8	158.9	158.9	164.9	
			SHC	119.2	152.4	185.7	112.4	145.7	179.0	105.4	138.7	172.0	98.4	131.7	164.9	
72		TC	219.3	219.3	219.3	205.4	205.4	205.4	191.1	191.1	191.1	176.1	176.1	176.1		
		SHC	85.8	118.7	151.6	79.0	112.0	145.0	72.1	105.2	138.3	65.1	98.3	131.4		
76		TC	—	237.0	237.0	—	222.1	222.1	—	206.8	206.8	—	191.1	191.1		
		SHC	—	91.4	122.5	—	84.8	116.5	—	78.0	110.2	—	71.2	103.6		
7500 cfm		EAT (wb)	58	TC	188.1	188.1	212.8	177.2	177.2	201.0	165.9	165.9	188.6	154.3	154.3	175.8
				SHC	163.3	188.1	212.8	153.5	177.2	201.0	143.3	165.9	188.6	132.8	154.3	175.8
	62		TC	191.5	191.5	214.2	177.5	177.5	209.2	166.2	166.2	196.4	154.4	154.4	183.1	
			SHC	152.0	183.1	214.2	145.8	177.5	209.2	135.9	166.2	196.4	125.7	154.4	183.1	
	67		TC	202.3	202.3	202.3	189.0	189.0	191.4	175.2	175.2	184.4	161.2	161.2	177.1	
			SHC	125.2	161.7	198.3	118.3	154.9	191.4	111.3	147.9	184.4	104.2	140.7	177.1	
	72	TC	222.3	222.3	222.3	208.1	208.1	208.1	193.3	193.3	193.3	178.3	178.3	178.3		
		SHC	88.4	124.7	161.0	81.6	118.0	154.3	74.7	111.1	147.5	67.7	104.2	140.7		
	76	TC	—	239.8	239.8	—	224.7	224.7	—	209.2	209.2	—	—	—		
		SHC	—	94.7	129.6	—	88.1	123.4	—	81.3	116.9	—	—	—		

LEGEND

- Do Not Operate
- cfm — Cubic Feet Per Minute (Supply Air)
- EAT (db) — Entering Air Temperature (dry bulb)
- EAT (wb) — Entering Air Temperature (wet bulb)
- SHC — Sensible Heat Capacity (1000 Btuh) Gross
- TC — Total Capacity (1000 Btuh) Gross

NOTE: See minimum-maximum airflow ratings on page 6.

Performance data (cont)

RGV/RAV180 SINGLE-STAGE COOLING CAPACITIES

RGV/RAV180			AMBIENT TEMPERATURE (°F)													
			85			95			105			115				
			EAT (db)			EAT (db)			EAT (db)			EAT (db)				
			75	80	85	75	80	85	75	80	85	75	80	85		
2500 cfm	EAT (wb)	58	TC	93.5	93.5	102.9	85.6	85.6	96.7	77.6	77.6	89.9	69.9	69.9	82.2	
			SHC	76.9	89.9	102.9	70.8	83.8	96.7	64.5	77.2	89.9	57.7	69.9	82.2	
		62	TC	103.3	103.3	103.3	94.9	94.9	94.9	86.2	86.2	86.2	77.1	77.1	77.1	
			SHC	68.1	81.1	94.1	62.2	75.2	88.2	56.2	69.2	82.2	50.0	63.1	76.1	
		67	TC	116.8	116.8	116.8	108.0	108.0	108.0	98.8	98.8	98.8	89.2	89.2	89.2	
			SHC	57.0	69.8	82.6	51.1	63.9	76.8	45.1	57.9	70.8	38.9	51.8	64.7	
	72	TC	131.3	131.3	131.3	122.1	122.1	122.1	112.4	112.4	112.4	102.3	102.3	102.3		
		SHC	46.4	58.1	69.8	40.2	52.4	64.6	34.0	46.5	58.9	27.8	40.4	53.0		
	76	TC	—	143.3	143.3	—	134.3	134.3	—	124.2	124.2	—	113.6	113.6		
		SHC	—	49.6	63.0	—	43.3	57	—	37.3	51.0	—	31.1	44.9		
	2900 cfm	EAT (wb)	58	TC	99.9	99.9	112.5	92.0	92.0	106.1	84.1	84.1	97.5	76.3	76.3	89.1
				SHC	84.0	98.3	112.5	77.9	92.0	106.1	70.5	84.0	97.5	63.2	76.1	89.1
62			TC	108.4	108.4	108.4	99.6	99.6	99.6	90.4	90.4	92.5	80.9	80.9	86.2	
			SHC	74.8	89.8	104.8	68.7	83.7	98.7	62.6	77.5	92.5	56.2	71.2	86.2	
67			TC	122.0	122.0	122.0	112.8	112.8	112.8	103.1	103.1	103.1	93.1	93.1	93.1	
			SHC	61.6	76.4	91.2	55.6	70.4	85.2	49.4	64.3	79.1	43.1	58.0	72.9	
72		TC	136.8	136.8	136.8	127.1	127.1	127.1	117.0	117.0	117.0	106.4	106.4	106.4		
		SHC	48.6	62.8	77.0	42.5	56.9	71.3	36.3	50.8	65.3	29.9	44.6	59.2		
76		TC	—	149.7	149.7	—	139.8	139.8	—	129.1	129.1	—	117.8	117.8		
		SHC	—	51.9	67.8	—	45.6	61.6	—	39.7	55.6	—	33.6	46.0		
3300 cfm		EAT (wb)	58	TC	105.5	105.5	120.7	98.1	98.1	112.8	89.8	89.8	104.0	81.5	81.5	95.1
				SHC	90.2	105.5	120.7	83.3	98.1	112.8	75.7	89.8	104.0	68.0	81.5	95.1
	62		TC	112.4	112.4	114.8	103.3	103.3	108.6	93.8	93.8	102.2	84.0	84.0	95.5	
			SHC	81.0	97.9	114.8	74.8	91.7	108.6	68.5	85.4	102.2	61.9	78.7	95.5	
	67		TC	126.2	126.2	126.2	116.6	116.6	116.6	106.6	106.6	106.6	96.2	96.2	96.2	
			SHC	65.8	82.6	99.3	59.7	76.4	93.2	53.4	70.2	87.0	47.0	63.8	80.6	
	72	TC	141.2	141.2	141.2	131.1	131.1	131.1	120.5	120.5	120.5	109.6	109.6	109.6		
		SHC	50.7	67.1	83.4	44.5	61.0	77.4	38.3	54.8	71.3	31.8	48.4	65.0		
	76	TC	—	154.5	154.5	—	143.7	143.7	—	132.6	132.6	—	121.0	121		
		SHC	—	54.2	72.3	—	48.3	66.5	—	42.3	57.0	—	36.0	51.5		
	3700 cfm	EAT (wb)	58	TC	111.0	111.0	126.9	103.4	103.4	118.7	95.2	95.2	109.9	86.6	86.6	100.6
				SHC	95.2	111.0	126.9	88.1	103.4	118.7	80.5	95.2	109.9	72.5	86.6	100.6
62			TC	115.8	115.8	124.4	106.3	106.3	117.9	96.7	96.7	111.1	86.9	86.9	103.6	
			SHC	86.9	105.6	124.4	80.5	99.2	117.9	73.9	92.5	111.1	67.0	85.3	103.6	
67			TC	129.6	129.6	129.6	119.6	119.6	119.6	109.4	109.4	109.4	98.8	98.8	98.8	
			SHC	69.8	88.5	107.1	63.5	82.2	100.9	57.2	75.9	94.6	50.7	69.4	88.1	
72		TC	144.7	144.7	144.7	134.3	134.3	134.3	123.4	123.4	123.4	112.2	112.2	112.2		
		SHC	52.7	71.0	89.3	46.4	64.8	83.2	40.1	58.5	76.9	33.6	52.0	70.5		
76		TC	—	157.8	157.8	—	146.8	146.8	—	135.4	135.4	—	123.4	123.4		
		SHC	—	56.8	72.4	—	50.7	67.5	—	44.4	61.8	—	38.0	55.7		
4150 cfm		EAT (wb)	58	TC	116.5	116.5	132.9	108.2	108.2	124.0	99.6	99.6	114.8	90.6	90.6	105.1
				SHC	100.0	116.5	132.9	92.3	108.2	124.0	84.4	99.6	114.8	76.1	90.6	105.1
	62		TC	119.0	119.0	134.2	109.6	109.6	127.2	100.3	100.3	118.6	91.5	91.5	108.3	
			SHC	92.9	113.5	134.2	86.3	106.8	127.2	78.8	98.7	118.6	70.6	89.5	108.3	
	67		TC	132.7	132.7	132.7	122.5	122.5	122.5	112.0	112.0	112.0	101.1	101.1	101.1	
			SHC	74.0	94.7	115.5	67.6	88.4	109.2	61.2	82.0	102.8	54.6	75.4	96.2	
	72	TC	147.9	147.9	147.9	137.2	137.2	137.2	126.1	126.1	126.1	114.5	114.5	114.5		
		SHC	54.7	75.1	95.6	48.4	68.8	89.3	41.9	62.4	82.9	35.4	55.9	76.4		
	76	TC	—	161.0	161.0	—	149.7	149.7	—	137.9	137.9	—	125.6	125.6		
		SHC	—	59.3	78.2	—	53.0	72.4	—	46.7	66.3	—	40.1	59.9		

LEGEND

- Do Not Operate
- cfm — Cubic Feet Per Minute (Supply Air)
- EAT (db) — Entering Air Temperature (dry bulb)
- EAT (wb) — Entering Air Temperature (wet bulb)
- SHC — Sensible Heat Capacity (1000 Btuh) Gross
- TC — Total Capacity (1000 Btuh) Gross

NOTE: See minimum-maximum airflow ratings on page 6.

Performance data (cont)

RGV/RAV180 — UNIT WITH HOT GAS RE-HEAT SYSTEM IN SUBCOOLING MODE — COOLING CAPACITIES

TEMP (°F) AIR ENTERING CONDENSER (Edb)		AIR ENTERING EVAPORATOR — SCFM/BF (80°F db)								
		4500/0.09			6000/0.12			7500/0.14		
		Air Entering Evaporator — Ewb (°F)								
		72	67	62	72	67	62	72	67	62
75	TC	203.0	181.0	162.0	213.0	196.0	175.0	225.0	202.0	183.0
	SHC	82.0	103.0	124.0	93.0	125.0	152.0	109.0	142.0	175.0
	kW	14.1	13.7	13.4	14.2	14.1	13.7	14.5	14.1	13.8
85	TC	190.0	168.0	149.0	202.0	181.0	161.0	210.0	189.0	169.0
	SHC	70.0	91.0	113.0	83.0	112.0	139.0	95.0	130.0	162.0
	kW	15.3	14.9	14.6	15.5	15.2	14.8	15.7	15.3	14.9
95	TC	176.0	155.0	137.0	187.0	166.0	148.0	195.0	174.0	155.0
	SHC	57.0	79.0	102.0	70.0	98.0	127.0	81.0	117.0	149.0
	kW	16.6	16.2	15.9	16.9	16.5	16.1	17.0	16.7	16.3
105	TC	161.0	141.0	124.0	172.0	152.0	134.0	179.0	159.0	141.0
	SHC	44.0	67.0	90.0	56.0	85.0	114.0	67.0	103.0	135.0
	kW	18.1	17.7	17.4	18.4	17.9	17.6	18.5	18.1	17.8
115	TC	146.0	127.0	110.0	156.0	137.0	120.0	162.0	143.0	126.0
	SHC	31.0	54.0	78.0	42.0	73.0	101.0	52.0	89.0	121.0
	kW	19.8	19.4	19.1	20.0	19.7	19.3	20.2	19.8	19.4
125	TC	130.0	113.0	97.0	139.0	121.0	105.0	145.0	127.0	110.0
	SHC	18.0	42.0	65.0	28.0	59.0	88.0	37.0	75.0	106.0
	kW	21.6	21.2	20.8	21.8	21.4	21.0	21.9	21.6	21.1

RGV/RAV180 — UNIT WITH HOT GAS RE-HEAT SYSTEM IN HOT GAS REHEAT MODE — COOLING CAPACITIES

TEMP (°F) AIR ENTERING CONDENSER (Edb)		AIR ENTERING EVAPORATOR — Ewb (°F)								
		75 Dry Bulb 62.5 Wet Bulb (50% Relative)			75 Dry Bulb 64 Wet Bulb (56% Relative)			75 Dry Bulb 65.3 Wet Bulb (60% Relative)		
		Air Entering Evaporator — cfm								
		4500	6000	7500	4500	6000	7500	4500	6000	7500
80	TC	60.0	63.0	65.0	64.0	66.0	68.0	67.0	68.0	70.0
	SHC	9.0	5.0	2.0	16.0	11.0	7.0	22.0	16.0	11.0
	kW	12.8	12.8	12.9	12.9	12.9	13.0	12.9	13.0	13.0
75	TC	63.0	66.0	68.0	67.0	69.0	71.0	70.0	72.0	74.0
	SHC	12.0	8.0	4.0	19.0	14.0	9.0	25.0	19.0	13.0
	kW	12.5	12.5	12.6	12.6	12.6	12.6	12.6	12.6	12.6
70	TC	66.0	69.0	71.0	70.0	73.0	74.0	73.0	75.0	77.0
	SHC	14.0	10.0	7.0	22.0	16.0	12.0	28.0	21.0	16.0
	kW	12.4	12.4	12.5	12.5	12.5	12.5	12.5	12.5	12.5
60	TC	72.0	74.0	77.0	76.0	79.0	80.0	79.0	81.0	83.0
	SHC	21.0	15.0	11.0	26.0	21.0	17.0	33.0	26.0	21.0
	kW	12.4	12.4	12.4	12.4	12.4	12.4	12.4	12.4	12.4
50	TC	77.0	80.0	82.0	82.0	84.0	86.0	85.0	87.0	89.0
	SHC	24.0	19.0	16.0	31.0	26.0	22.0	38.0	32.0	26.0
	kW	12.4	12.4	12.4	12.4	12.4	12.4	12.4	12.4	12.4
40	TC	82.0	85.0	87.0	87.0	90.0	92.0	90.0	92.0	95.0
	SHC	28.0	24.0	20.0	36.0	31.0	27.0	43.0	37.0	31.0
	kW	12.4	12.4	12.4	12.4	12.4	12.4	12.4	12.4	12.4

LEGEND

- Ewb** — Entering wet bulb
- kW** — compressor Power Input
- SCFM/BF** — Standard Cubic Feet per Minute/Bypass Factor
- SHC** — Sensible Heat Capacity (1000 Btuh) Gross
- TC** — Total Capacity (1000 Btuh) Gross

Performance data (cont)

PRESSURE DROPS FOR ELECTRIC HEATING UNITS

7.5 AND 8.5 TON UNITS

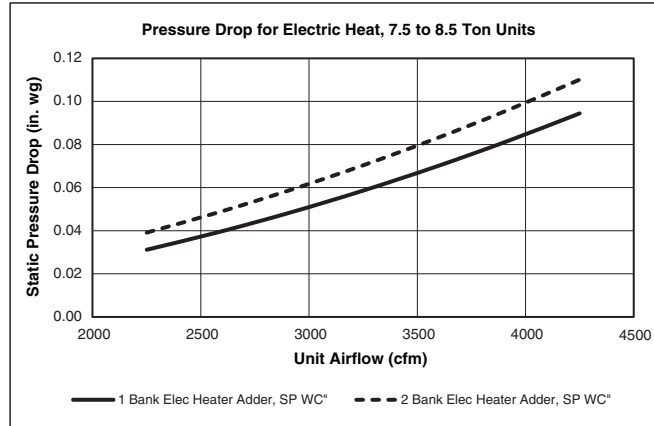

10 AND 12.5 TON UNITS

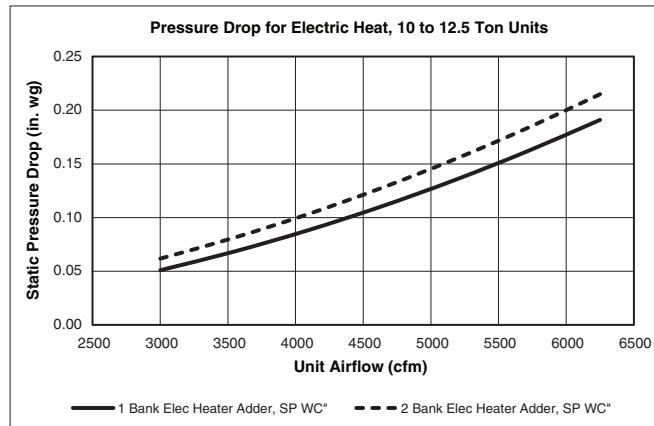

15 TON UNITS

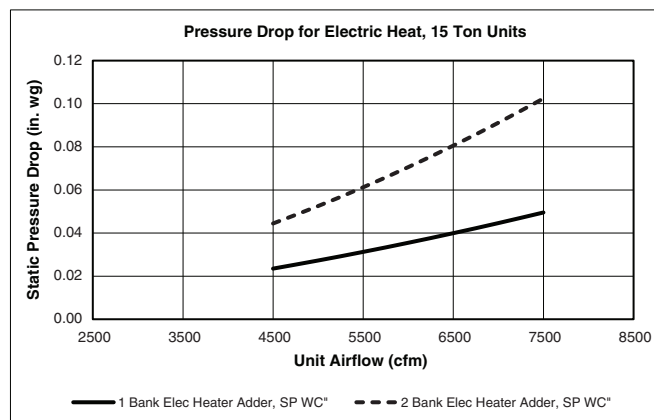

Performance data (cont)

PRESSURE DROPS FOR GAS HEATING UNITS

GAS HEAT STAGES

RGV UNIT SIZE	HEAT SIZE		
	LOW	MEDIUM	HIGH
090	1	2	2
102	1	2	2
120	2	2	2
150	2	2	2
180	2	2	2

GAS HEAT STATIC PRESSURE DEDUCTIONS — 7.5 TO 8.5 TON UNITS

CFM	2250	2585	2915	3250	3585	3915	4250
Medium Gas Heat Deduction	-0.04	-0.04	-0.03	-0.02	-0.02	-0.01	0.01
Low Gas Heat Deduction	0.01	0.01	0.02	0.04	0.05	0.06	0.08

GAS HEAT STATIC PRESSURE DEDUCTIONS — 10 TO 12.5 TON UNITS

CFM	3000	3540	4085	4625	5165	5710	6250
Medium Gas Heat Deduction	0.00	0.02	0.04	0.06	0.08	0.11	0.15
Low Gas Heat Deduction	-0.03	0.00	0.04	0.08	0.13	0.20	0.27

GAS HEAT STATIC PRESSURE DEDUCTIONS — 15 TON UNITS

CFM	4500	5000	5500	6000	6500	7000	7500
High Gas Heat Deduction	0.12	0.14	0.16	0.17	0.19	0.21	0.23
Medium Gas Heat Deduction	0.21	0.24	0.26	0.29	0.31	0.34	0.36
Low Gas Heat Deduction	0.20	0.22	0.25	0.27	0.29	0.32	0.34

Performance data (cont)

FIELD-INSTALLED ACCESSORY ELECTRIC HEATER DATA

RAV UNIT SIZE	VOLTAGE	HEATER MODEL NUMBER	NUMBER OF STAGES
090	208/230	CRHEATER411A00	1
		CRHEATER412A00	1
		CRHEATER414A00	2
		CRHEATER415A00	2
		CRHEATER416A00	2
	460	CRHEATER420A00	1
		CRHEATER421A00	2
		CRHEATER422A00	2
		CRHEATER423A00	2
	575	CRHEATER425A00	1
CRHEATER427A00		2	
102	208/230	CRHEATER411A00	1
		CRHEATER412A00	1
		CRHEATER414A00	2
		CRHEATER415A00	2
		CRHEATER416A00	2
	460	CRHEATER420A00	1
		CRHEATER421A00	2
		CRHEATER422A00	2
		CRHEATER423A00	2
	575	CRHEATER425A00	1
CRHEATER427A00		2	
120	208/230	CRHEATER411A00	1
		CRHEATER412A00	1
		CRHEATER415A00	2
		CRHEATER416A00	2
		CRHEATER417A00	2
	460	CRHEATER420A00	1
		CRHEATER422A00	2
		CRHEATER423A00	2
		CRHEATER424A00	2
	575	CRHEATER425A00	1
CRHEATER427A00		2	
CRHEATER428A00		2	
150	208/230	CRHEATER411A00	1
		CRHEATER412A00	1
		CRHEATER415A00	2
		CRHEATER416A00	2
		CRHEATER417A00	2
	460	CRHEATER420A00	1
		CRHEATER422A00	2
		CRHEATER423A00	2
		CRHEATER424A00	2
	575	CRHEATER425A00	1
CRHEATER427A00		2	
CRHEATER428A00		2	

Performance data (cont)

FIELD-INSTALLED ACCESSORY ELECTRIC HEATER DATA (cont)

RAV UNIT SIZE	VOLTAGE	HEATER MODEL NUMBER	NUMBER OF STAGES
180	208/230	CRHEATER412A00	1
		CRHEATER414A00	2
		CRHEATER415A00	2
		CRHEATER416A00	2
		CRHEATER417A00	2
		CRHEATER451A00	2
	460	CRHEATER420A00	1
		CRHEATER421A00	2
		CRHEATER422A00	2
		CRHEATER423A00	2
		CRHEATER424A00	2
		CRHEATER452A00	1
	575	CRHEATER425A00	1
		CRHEATER427A00	2
		CRHEATER428A00	2
		CRHEATER453A00	2

Performance data (cont)

ECONOMIZER BAROMETRIC RELIEF AND DAMPER LEAKAGE — 7.5 TO 12.5 TON UNITS

HORIZONTAL ECONOMIZER BAROMETRIC RELIEF

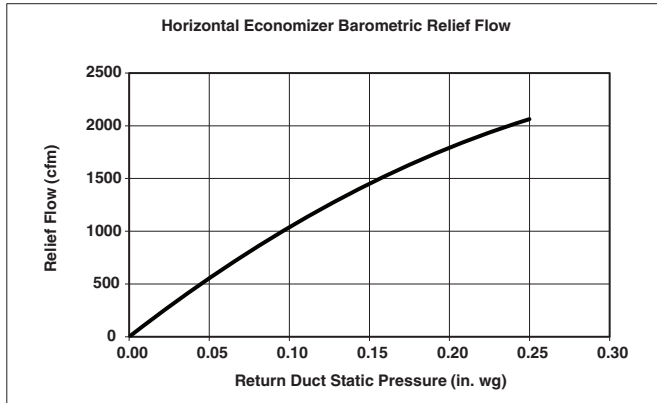

VERTICAL ECONOMIZER BAROMETRIC RELIEF

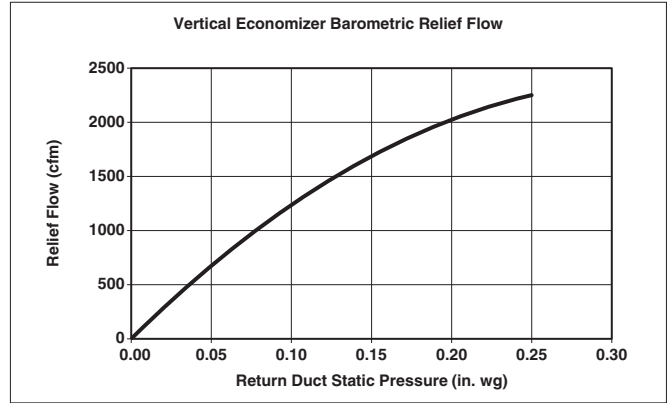

HORIZONTAL ECONOMIZER DAMPER LEAKAGE

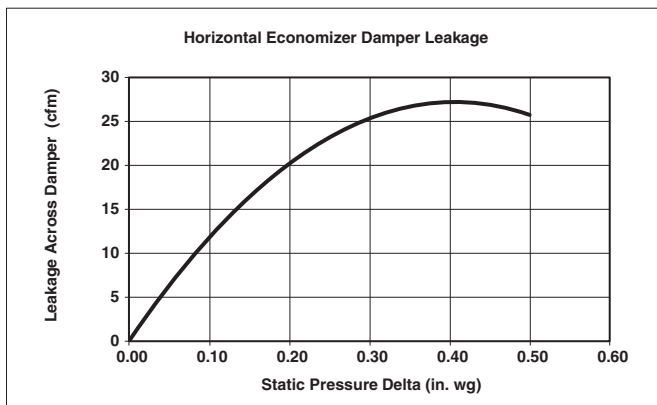

VERTICAL ECONOMIZER DAMPER LEAKAGE

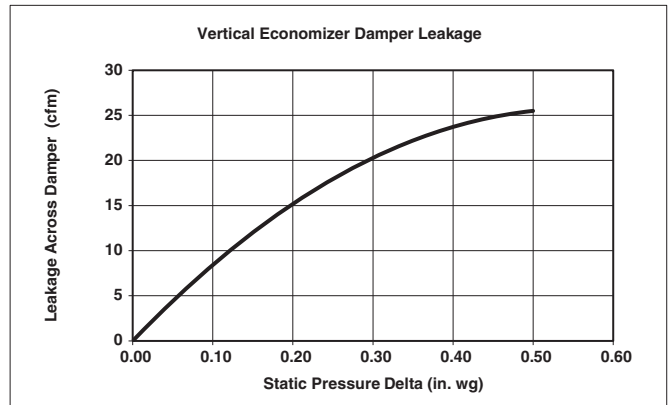

Performance data (cont)

ECONOMIZER BAROMETRIC RELIEF AND DAMPER LEAKAGE — 15 TON UNITS

HORIZONTAL ECONOMIZER BAROMETRIC RELIEF

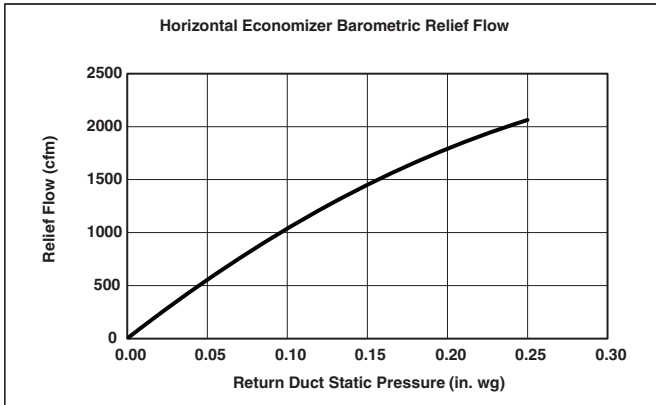

VERTICAL ECONOMIZER BAROMETRIC RELIEF

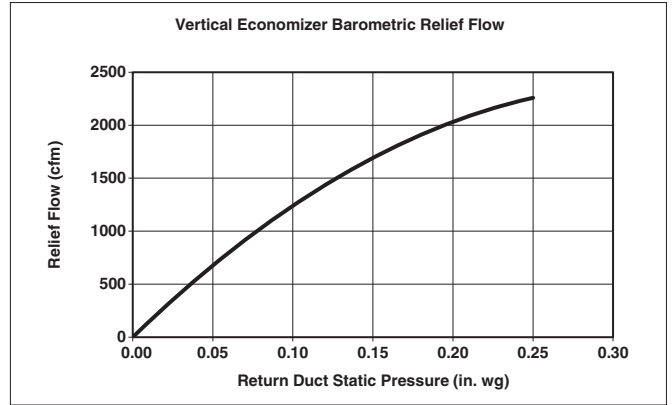

HORIZONTAL ECONOMIZER DAMPER LEAKAGE

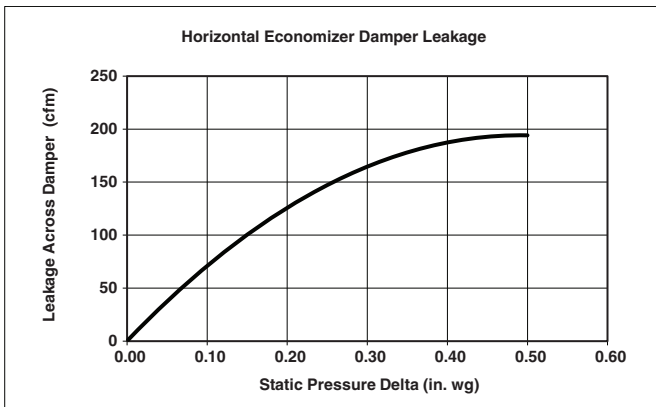

VERTICAL ECONOMIZER DAMPER LEAKAGE

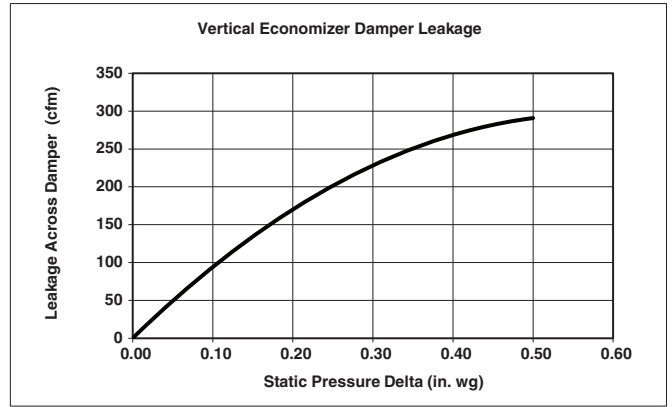

ECONOMIZER PRESSURE DROP

7.5 TO 12.5 TON UNITS

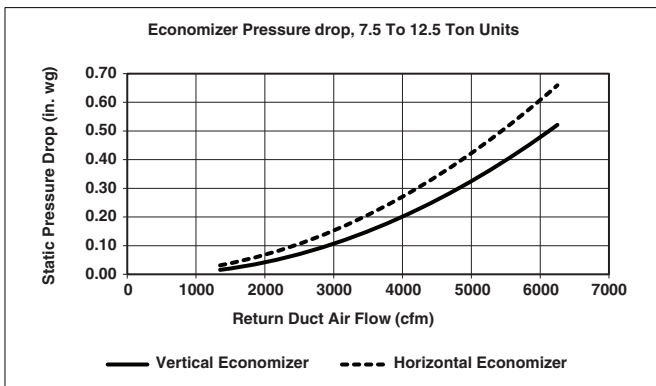

15 TON UNITS

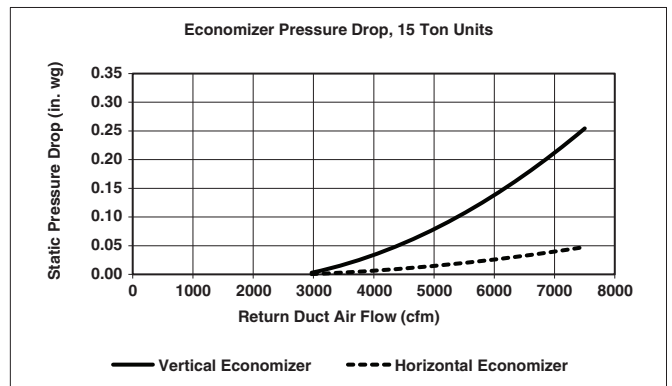

Performance data (cont)

HOT GAS RE-HEAT COIL PRESSURE DROPS — 7.5 TO 15 TON UNITS

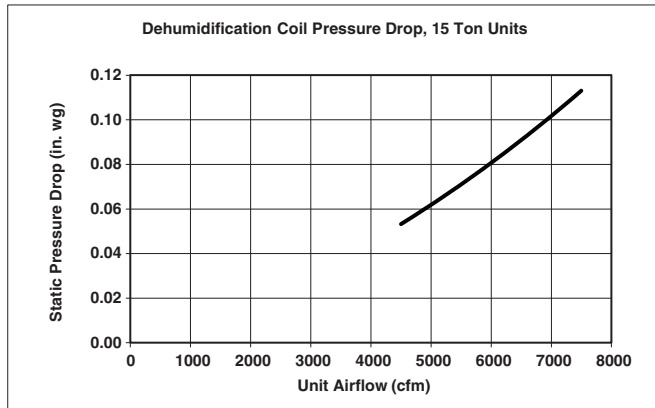
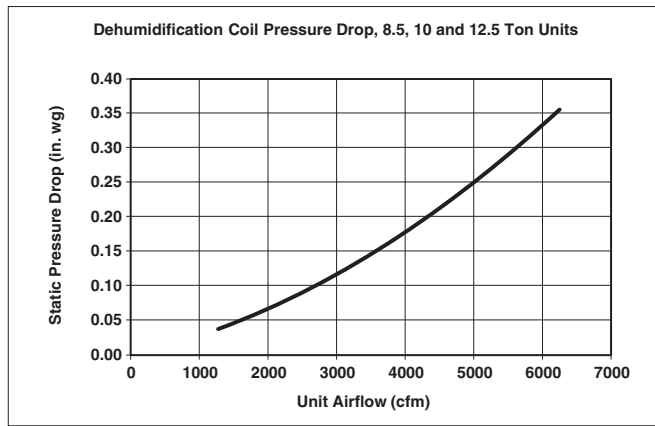
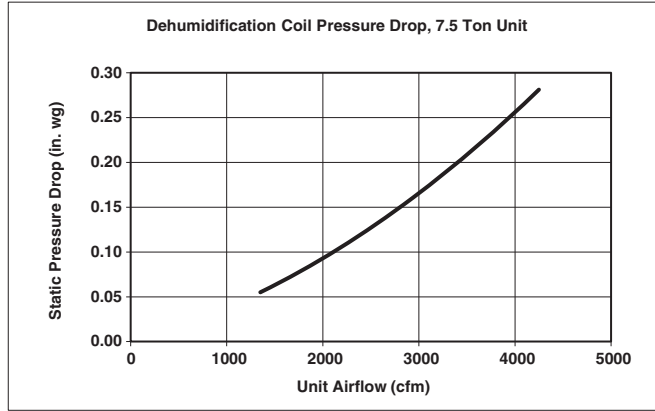

Fan data

GENERAL FAN PERFORMANCE NOTES

1. Interpolation is permissible. Do not extrapolate.
2. External static pressure is the static pressure difference between the return duct and the supply duct plus the static pressure caused by any FIOPs or accessories.
3. Tabular data accounts for pressure loss due to clean filters, unit casing, wet coils, and highest gas heat exchanger (when gas heat unit).
4. Factory options and accessories may effect static pressure losses. Gas heat unit fan tables assume highest gas heat models; for fan selections with low or medium heat models, the user must deduct low and medium heat static pressures. Selection software is available, through your salesperson, to help you select the best motor/drive combination for your application.
5. The fan performance tables offer motor/drive recommendations. In cases when two motor/drive combinations would work, the lower horsepower option is recommended.
6. For information on the electrical properties of the fan motors, please see the Electrical information section of this book.
7. For more information on the performance limits of the fan motors, see the application data section of this book.
8. The EPACT (Energy Policy Act of 1992) regulates energy requirements for specific types of indoor fan motors. Motors regulated by EPACT include any general purpose, T-frame (three-digit, 143 and larger), single-speed, foot mounted, polyphase, squirrel cage induction motors of NEMA (National Electrical Manufacturers Association) design A and B, manufactured for use in the United States. Ranging from 1 to 200 Hp, these continuous-duty motors operate on 230 and 460 volt, 60 Hz power. If a motor does not fit into these specifications, the motor does not have to be replaced by an EPACT compliant energy-efficient motor. Variable-speed motors are exempt from EPACT compliance requirements.

Fan data (cont)

RGV090 — 7.5 TON VERTICAL SUPPLY (RPM — BHP)

CFM	AVAILABLE EXTERNAL STATIC PRESSURE (in. wg)									
	0.2		0.4		0.6		0.8		1.0	
	rpm	bhp	rpm	bhp	rpm	bhp	rpm	bhp	rpm	bhp
2250	1045	0.43	1166	0.60	1273	0.78	1372	0.97	1463	1.18
2440	1111	0.51	1226	0.69	1329	0.88	1424	1.08	1512	1.30
2625	1178	0.61	1288	0.80	1387	1.00	1478	1.21	1564	1.43
2810	1246	0.72	1351	0.91	1446	1.12	1534	1.34	1617	1.57
3000	1314	0.83	1415	1.04	1507	1.26	1592	1.48	1672	1.71
3190	1383	0.96	1480	1.17	1568	1.40	1651	1.63	1729	1.87
3375	1453	1.09	1545	1.31	1631	1.55	1711	1.78	1786	2.03
3560	1523	1.23	1612	1.46	1694	1.70	1772	1.94	1845	2.20
3750	1594	1.38	1679	1.62	1759	1.86	1834	2.11	1905	2.36

CFM	AVAILABLE EXTERNAL STATIC PRESSURE (in. wg)									
	1.2		1.4		1.6		1.8		2.0	
	rpm	bhp	rpm	bhp	rpm	bhp	rpm	bhp	rpm	bhp
2250	1548	1.40	1629	1.63	1706	1.87	1778	2.12	1848	2.38
2440	1595	1.52	1674	1.76	1749	2.01	1821	2.27	1889	2.53
2625	1645	1.66	1721	1.90	1794	2.16	1865	2.42	1932	2.69
2810	1696	1.81	1770	2.06	1842	2.32	1910	2.58	1976	2.86
3000	1748	1.96	1821	2.22	1891	2.48	1958	2.75	2022	3.03
3190	1803	2.12	1873	2.38	1941	2.65	2007	2.93	—	—
3375	1858	2.29	1927	2.55	1994	2.83	2058	3.11	—	—
3560	1915	2.45	1982	2.72	2047	3.00	—	—	—	—
3750	1973	2.62	2039	2.90	2102	3.17	—	—	—	—

Std/Med Static 1045-2000 rpm, 2.4 Max bhp

High Static 1045-2200 rpm, 3.0 Max bhp

RGV090 — STANDARD/MEDIUM STATIC — 7.5 TON VERTICAL SUPPLY (RPM — VDC)

CFM	AVAILABLE EXTERNAL STATIC PRESSURE (in. wg)									
	0.2		0.4		0.6		0.8		1.0	
	rpm	Vdc	rpm	Vdc	rpm	Vdc	rpm	Vdc	rpm	Vdc
2250	1045	5.1	1166	5.7	1273	6.3	1372	6.8	1463	7.2
2440	1111	5.4	1226	6.0	1329	6.5	1424	7.0	1512	7.5
2625	1178	5.8	1288	6.3	1387	6.8	1478	7.3	1564	7.8
2810	1246	6.1	1351	6.7	1446	7.2	1534	7.6	1617	8.0
3000	1314	6.5	1415	7.0	1507	7.5	1592	7.9	1672	8.3
3190	1383	6.8	1480	7.3	1568	7.8	1651	8.2	1729	8.6
3375	1453	7.2	1545	7.7	1631	8.1	1711	8.5	1786	8.9
3560	1523	7.5	1612	8.0	1694	8.4	1772	8.8	1845	9.2
3750	1594	7.9	1679	8.3	1759	8.8	1834	9.1	1905	9.5

CFM	AVAILABLE EXTERNAL STATIC PRESSURE (in. wg)									
	1.2		1.4		1.6		1.8		2.0	
	rpm	Vdc	rpm	Vdc	rpm	Vdc	rpm	Vdc	rpm	Vdc
2250	1548	7.7	1629	8.1	1706	8.5	1778	8.9	1848	9.2
2440	1595	7.9	1674	8.3	1749	8.7	1821	9.1	—	—
2625	1645	8.2	1721	8.6	1794	8.9	—	—	—	—
2810	1696	8.4	1770	8.8	1842	9.2	—	—	—	—
3000	1748	8.7	1821	9.1	—	—	—	—	—	—
3190	1803	9.0	1873	9.3	—	—	—	—	—	—
3375	1858	9.3	—	—	—	—	—	—	—	—
3560	—	—	—	—	—	—	—	—	—	—
3750	—	—	—	—	—	—	—	—	—	—

Std/Med Static 1045-2000 rpm

Fan data (cont)

RGV090 — HIGH STATIC — 7.5 TON VERTICAL SUPPLY (RPM — VDC)

CFM	AVAILABLE EXTERNAL STATIC PRESSURE (in. wg)									
	0.2		0.4		0.6		0.8		1.0	
	rpm	Vdc	rpm	Vdc	rpm	Vdc	rpm	Vdc	rpm	Vdc
2250	1045	4.7	1166	5.2	1273	5.7	1372	6.2	1463	6.6
2440	1111	5.0	1226	5.5	1329	6.0	1424	6.4	1512	6.8
2625	1178	5.3	1288	5.8	1387	6.2	1478	6.7	1564	7.1
2810	1246	5.6	1351	6.1	1446	6.5	1534	6.9	1617	7.3
3000	1314	5.9	1415	6.4	1507	6.8	1592	7.2	1672	7.6
3190	1383	6.2	1480	6.7	1568	7.1	1651	7.5	1729	7.8
3375	1453	6.6	1545	7.0	1631	7.4	1711	7.7	1786	8.1
3560	1523	6.9	1612	7.3	1694	7.7	1772	8.0	1845	8.4
3750	1594	7.2	1679	7.6	1759	8.0	1834	8.3	1905	8.6

CFM	AVAILABLE EXTERNAL STATIC PRESSURE (in. wg)									
	1.2		1.4		1.6		1.8		2.0	
	rpm	Vdc	rpm	Vdc	rpm	Vdc	rpm	Vdc	rpm	Vdc
2250	1548	7.0	1629	7.4	1706	7.7	1778	8.1	1848	8.4
2440	1595	7.2	1674	7.6	1749	7.9	1821	8.3	1889	8.6
2625	1645	7.4	1721	7.8	1794	8.1	1865	8.5	1932	8.8
2810	1696	7.7	1770	8.0	1842	8.3	1910	8.7	1976	9.0
3000	1748	7.9	1821	8.3	1891	8.6	1958	8.9	2022	9.2
3190	1803	8.2	1873	8.5	1941	8.8	2007	9.1	—	—
3375	1858	8.4	1927	8.7	1994	9.0	2058	9.3	—	—
3560	1915	8.7	1982	9.0	2047	9.3	—	—	—	—
3750	1973	9.0	2039	9.3	2102	9.5	—	—	—	—

High Static 1045-2200 rpm

Fan data (cont)

RGV102 — 8.5 TON VERTICAL SUPPLY (RPM — BHP)

CFM	AVAILABLE EXTERNAL STATIC PRESSURE (in. wg)									
	0.2		0.4		0.6		0.8		1.0	
	rpm	bhp	rpm	bhp	rpm	bhp	rpm	bhp	rpm	bhp
2550	1091	0.48	1198	0.63	1298	0.81	1391	0.99	1478	1.19
2760	1164	0.58	1264	0.74	1359	0.92	1448	1.11	1532	1.31
2975	1238	0.69	1332	0.85	1422	1.04	1507	1.24	1588	1.45
3190	1312	0.81	1402	0.98	1487	1.17	1569	1.38	1646	1.59
3400	1388	0.94	1473	1.12	1554	1.32	1632	1.53	1706	1.75
3610	1464	1.08	1544	1.27	1622	1.47	1696	1.69	1768	1.91
3825	1541	1.24	1617	1.43	1691	1.64	1762	1.85	1831	2.08
4040	1618	1.40	1691	1.59	1761	1.80	1830	2.02	1896	2.25
4250	1696	1.56	1765	1.76	1832	1.97	1898	2.19	1962	2.42

CFM	AVAILABLE EXTERNAL STATIC PRESSURE (in. wg)									
	1.2		1.4		1.6		1.8		2.0	
	rpm	bhp	rpm	bhp	rpm	bhp	rpm	bhp	rpm	bhp
2550	1559	1.40	1636	1.61	1709	1.84	1779	2.08	1846	2.32
2760	1611	1.53	1686	1.75	1758	1.98	1826	2.22	1892	2.47
2975	1665	1.67	1738	1.90	1808	2.14	1875	2.38	1939	2.63
3190	1721	1.82	1792	2.05	1860	2.30	1925	2.55	1988	2.80
3400	1778	1.98	1847	2.22	1913	2.46	1977	2.72	2039	2.98
3610	1837	2.14	1904	2.38	1969	2.64	2031	2.89	2091	3.16
3825	1898	2.31	1963	2.56	2026	2.81	2086	3.07	—	—
4040	1961	2.49	2023	2.73	2084	2.98	—	—	—	—
4250	2024	2.66	2085	2.90	2144	3.16	—	—	—	—

Std/Med Static 1091-2000 rpm, 2.4 Max bhp

High Static 1091-2200 rpm, 3.0 Max bhp

RGV102 — STANDARD/MEDIUM STATIC — 8.5 TON VERTICAL SUPPLY (RPM — VDC)

CFM	AVAILABLE EXTERNAL STATIC PRESSURE (in. wg)									
	0.2		0.4		0.6		0.8		1.0	
	rpm	Vdc	rpm	Vdc	rpm	Vdc	rpm	Vdc	rpm	Vdc
2250	1091	5.3	1198	5.9	1298	6.4	1391	6.9	1478	7.3
2440	1164	5.7	1264	6.2	1359	6.7	1448	7.2	1532	7.6
2625	1238	6.1	1332	6.6	1422	7.0	1507	7.5	1588	7.9
2810	1312	6.5	1402	6.9	1487	7.4	1569	7.8	1646	8.2
3000	1388	6.9	1473	7.3	1554	7.7	1632	8.1	1706	8.5
3190	1464	7.2	1544	7.7	1622	8.1	1696	8.4	1768	8.8
3375	1541	7.6	1617	8.0	1691	8.4	1762	8.8	1831	9.1
3560	1618	8.0	1691	8.4	1761	8.8	1830	9.1	1896	9.5
3750	1696	8.4	1765	8.8	1832	9.1	1898	9.5	1962	9.8

CFM	AVAILABLE EXTERNAL STATIC PRESSURE (in. wg)									
	1.2		1.4		1.6		1.8		2.0	
	rpm	Vdc	rpm	Vdc	rpm	Vdc	rpm	Vdc	rpm	Vdc
2550	1559	7.7	1636	8.1	1709	8.5	1779	8.9	1846	9.2
2760	1611	8.0	1686	8.4	1758	8.8	1826	9.1	—	—
2975	1665	8.3	1738	8.7	1808	9.0	1875	9.4	—	—
3190	1721	8.6	1792	8.9	1860	9.3	—	—	—	—
3400	1778	8.9	1847	9.2	—	—	—	—	—	—
3610	1837	9.2	1904	9.5	—	—	—	—	—	—
3825	1898	9.5	—	—	—	—	—	—	—	—
4040	—	—	—	—	—	—	—	—	—	—
4250	—	—	—	—	—	—	—	—	—	—

Std/Med Static 1091-2000 rpm

Fan data (cont)

RGV102 — HIGH STATIC — 8.5 TON VERTICAL SUPPLY (RPM — VDC)

CFM	AVAILABLE EXTERNAL STATIC PRESSURE (in. wg)									
	0.2		0.4		0.6		0.8		1.0	
	rpm	Vdc	rpm	Vdc	rpm	Vdc	rpm	Vdc	rpm	Vdc
2550	1091	4.9	1198	5.4	1298	5.8	1391	6.3	1478	6.7
2760	1164	5.2	1264	5.7	1359	6.1	1448	6.5	1532	6.9
2975	1238	5.6	1332	6.0	1422	6.4	1507	6.8	1588	7.2
3190	1312	5.9	1402	6.3	1487	6.7	1569	7.1	1646	7.4
3400	1388	6.3	1473	6.6	1554	7.0	1632	7.4	1706	7.7
3610	1464	6.6	1544	7.0	1622	7.3	1696	7.7	1768	8.0
3825	1541	7.0	1617	7.3	1691	7.7	1762	8.0	1831	8.3
4040	1618	7.3	1691	7.7	1761	8.0	1830	8.3	1896	8.6
4250	1696	7.7	1765	8.0	1832	8.3	1898	8.6	1962	8.9

CFM	AVAILABLE EXTERNAL STATIC PRESSURE (in. wg)									
	1.2		1.4		1.6		1.8		2.0	
	rpm	Vdc	rpm	Vdc	rpm	Vdc	rpm	Vdc	rpm	Vdc
2550	1559	7.0	1636	7.4	1709	7.7	1779	8.1	1846	8.4
2760	1611	7.3	1686	7.6	1758	8.0	1826	8.3	1892	8.6
2975	1665	7.5	1738	7.9	1808	8.2	1875	8.5	1939	8.8
3190	1721	7.8	1792	8.1	1860	8.4	1925	8.7	1988	9.0
3400	1778	8.1	1847	8.4	1913	8.7	1977	9.0	2039	9.3
3610	1837	8.3	1904	8.6	1969	8.9	2031	9.2	2091	9.5
3825	1898	8.6	1963	8.9	2026	9.2	2086	9.5	—	—
4040	1961	8.9	2023	9.2	2084	9.5	—	—	—	—
4250	2024	9.2	2085	9.5	2144	9.7	—	—	—	—

High Static 1091-2200 rpm

Fan data (cont)

RGV120 — 10 TON VERTICAL SUPPLY (RPM — BHP)

CFM	AVAILABLE EXTERNAL STATIC PRESSURE (in. wg)									
	0.2		0.4		0.6		0.8		1.0	
	rpm	bhp	rpm	bhp	rpm	bhp	rpm	bhp	rpm	bhp
3000	1266	0.74	1360	0.92	1449	1.12	1534	1.32	1613	1.54
3250	1357	0.91	1444	1.09	1528	1.29	1608	1.51	1684	1.73
3500	1448	1.09	1530	1.28	1609	1.49	1685	1.72	1758	1.95
3750	1539	1.29	1617	1.49	1691	1.71	1764	1.94	1833	2.18
4000	1632	1.51	1705	1.72	1775	1.94	1844	2.18	1911	2.42
4250	1725	1.74	1794	1.96	1861	2.19	1926	2.43	1990	2.68
4500	1818	1.99	1884	2.22	1948	2.45	2010	2.69	2071	2.94
4750	1912	2.25	1974	2.47	2035	2.71	2095	2.96	2153	3.21
5000	2006	2.51	2066	2.74	2124	2.98	2181	3.23	—	—

CFM	AVAILABLE EXTERNAL STATIC PRESSURE (in. wg)									
	1.2		1.4		1.6		1.8		2.0	
	rpm	bhp	rpm	bhp	rpm	bhp	rpm	bhp	rpm	bhp
3000	1689	1.77	1762	2.01	1831	2.25	1897	2.50	1961	2.77
3250	1757	1.97	1827	2.21	1894	2.47	1959	2.73	2021	3.00
3500	1828	2.19	1895	2.44	1960	2.70	2023	2.97	2084	3.25
3750	1900	2.42	1965	2.68	2028	2.95	2089	3.22	2148	3.50
4000	1975	2.67	2038	2.94	2099	3.21	2158	3.49	—	—
4250	2052	2.94	2112	3.20	2171	3.48	—	—	—	—
4500	2130	3.20	2188	3.47	—	—	—	—	—	—
4750	—	—	—	—	—	—	—	—	—	—
5000	—	—	—	—	—	—	—	—	—	—

Std/Med Static 1266-2000 rpm, 2.4 Max bhp

High Static 1266-2200 rpm, 5.0 Max bhp

RGV120 — STANDARD/MEDIUM STATIC — 10 TON VERTICAL SUPPLY (RPM — VDC)

CFM	AVAILABLE EXTERNAL STATIC PRESSURE (in. wg)									
	0.2		0.4		0.6		0.8		1.0	
	rpm	Vdc	rpm	Vdc	rpm	Vdc	rpm	Vdc	rpm	Vdc
3000	1266	6.2	1360	6.7	1449	7.2	1534	7.6	1613	8.0
3250	1357	6.7	1444	7.1	1528	7.6	1608	8.0	1684	8.4
3500	1448	7.2	1530	7.6	1609	8.0	1685	8.4	1758	8.8
3750	1539	7.6	1617	8.0	1691	8.4	1764	8.8	1833	9.1
4000	1632	8.1	1705	8.5	1775	8.8	1844	9.2	—	—
4250	1725	8.6	1794	8.9	1861	9.3	—	—	—	—
4500	1818	9.1	1884	9.4	—	—	—	—	—	—
4750	1912	9.5	—	—	—	—	—	—	—	—
5000	—	—	—	—	—	—	—	—	—	—

CFM	AVAILABLE EXTERNAL STATIC PRESSURE (in. wg)									
	1.2		1.4		1.6		1.8		2.0	
	rpm	Vdc	rpm	Vdc	rpm	Vdc	rpm	Vdc	rpm	Vdc
3000	1689	8.4	1762	8.8	1831	9.1	—	—	—	—
3250	1757	8.8	1827	9.1	—	—	—	—	—	—
3500	1828	9.1	—	—	—	—	—	—	—	—
3750	—	—	—	—	—	—	—	—	—	—
4000	—	—	—	—	—	—	—	—	—	—
4250	—	—	—	—	—	—	—	—	—	—
4500	—	—	—	—	—	—	—	—	—	—
4750	—	—	—	—	—	—	—	—	—	—
5000	—	—	—	—	—	—	—	—	—	—

Std/Med Static 1266-2000 rpm

Fan data (cont)

RGV120 — HIGH STATIC — 10 TON VERTICAL SUPPLY (RPM — VDC)

CFM	AVAILABLE EXTERNAL STATIC PRESSURE (in. wg)									
	0.2		0.4		0.6		0.8		1.0	
	rpm	Vdc	rpm	Vdc	rpm	Vdc	rpm	Vdc	rpm	Vdc
3000	1266	5.7	1360	6.1	1449	6.5	1534	6.9	1613	7.3
3250	1357	6.1	1444	6.5	1528	6.9	1608	7.3	1684	7.6
3500	1448	6.5	1530	6.9	1609	7.3	1685	7.6	1758	8.0
3750	1539	6.9	1617	7.3	1691	7.7	1764	8.0	1833	8.3
4000	1632	7.4	1705	7.7	1775	8.0	1844	8.4	1911	8.7
4250	1725	7.8	1794	8.1	1861	8.4	1926	8.7	1990	9.0
4500	1818	8.2	1884	8.5	1948	8.8	2010	9.1	2071	9.4
4750	1912	8.7	1974	9.0	2035	9.2	2095	9.5	2153	9.8
5000	2006	9.1	2066	9.4	2124	9.6	2181	9.9	—	—

CFM	AVAILABLE EXTERNAL STATIC PRESSURE (in. wg)									
	1.2		1.4		1.6		1.8		2.0	
	rpm	Vdc	rpm	Vdc	rpm	Vdc	rpm	Vdc	rpm	Vdc
3000	1689	7.6	1762	8.0	1831	8.3	1897	8.6	1961	8.9
3250	1757	8.0	1827	8.3	1894	8.6	1959	8.9	2021	9.2
3500	1828	8.3	1895	8.6	1960	8.9	2023	9.2	2084	9.5
3750	1900	8.6	1965	8.9	2028	9.2	2089	9.5	2148	9.8
4000	1975	9.0	2038	9.3	2099	9.5	2158	9.8	—	—
4250	2052	9.3	2112	9.6	2171	9.9	—	—	—	—
4500	2130	9.7	2188	9.9	—	—	—	—	—	—
4750	—	—	—	—	—	—	—	—	—	—
5000	—	—	—	—	—	—	—	—	—	—

High Static 1266-2200 rpm

Fan data (cont)

RGV150 — 12.5 TON VERTICAL SUPPLY (RPM — BHP)

CFM	AVAILABLE EXTERNAL STATIC PRESSURE (in. wg)									
	0.2		0.4		0.6		0.8		1.0	
	rpm	bhp	rpm	bhp	rpm	bhp	rpm	bhp	rpm	bhp
3750	1320	1.21	1416	1.49	1503	1.79	1583	2.09	1657	2.39
4060	1414	1.48	1504	1.78	1587	2.09	1664	2.41	1736	2.74
4375	1509	1.79	1594	2.11	1673	2.44	1747	2.78	1817	3.13
4690	1604	2.14	1685	2.49	1761	2.84	1832	3.19	1899	3.56
5000	1700	2.54	1777	2.90	1849	3.26	1918	3.64	1983	4.03
5310	1797	2.97	1870	3.35	1939	3.73	2005	4.13	2068	4.53
5625	1894	3.44	1964	3.84	2030	4.24	2093	4.65	2154	5.06
5940	1992	3.95	2058	4.36	2121	4.77	—	—	—	—
6250	2090	4.50	2153	4.92	—	—	—	—	—	—

CFM	AVAILABLE EXTERNAL STATIC PRESSURE (in. wg)									
	1.2		1.4		1.6		1.8		2.0	
	rpm	bhp	rpm	bhp	rpm	bhp	rpm	bhp	rpm	bhp
3750	1727	2.71	1794	3.04	1857	3.37	1918	3.71	1976	4.06
4060	1804	3.08	1869	3.42	1930	3.77	1989	4.12	2046	4.49
4375	1883	3.48	1946	3.85	2005	4.21	2063	4.58	2119	4.97
4690	1963	3.93	2024	4.31	2082	4.69	2139	5.08	—	—
5000	2045	4.42	2104	4.81	—	—	—	—	—	—
5310	2128	4.93	—	—	—	—	—	—	—	—
5625	—	—	—	—	—	—	—	—	—	—
5940	—	—	—	—	—	—	—	—	—	—
6250	—	—	—	—	—	—	—	—	—	—

Std/Med Static 1320-2200 rpm, 3.0 Max bhp

High Static 1320-2200 rpm, 5.0 Max bhp

RGV150 — STANDARD/MEDIUM STATIC — 12.5 TON VERTICAL SUPPLY (RPM — VDC)

CFM	AVAILABLE EXTERNAL STATIC PRESSURE (in. wg)									
	0.2		0.4		0.6		0.8		1.0	
	rpm	Vdc	rpm	Vdc	rpm	Vdc	rpm	Vdc	rpm	Vdc
3750	1320	5.9	1416	6.4	1503	6.8	1583	7.2	1657	7.5
4060	1414	6.4	1504	6.8	1587	7.2	1664	7.5	1736	7.9
4375	1509	6.8	1594	7.2	1673	7.6	1747	7.9	—	—
4690	1604	7.2	1685	7.6	1761	8.0	—	—	—	—
5000	1700	7.7	1777	8.0	—	—	—	—	—	—
5310	1797	8.1	—	—	—	—	—	—	—	—
5625	—	—	—	—	—	—	—	—	—	—
5940	—	—	—	—	—	—	—	—	—	—
6250	—	—	—	—	—	—	—	—	—	—

CFM	AVAILABLE EXTERNAL STATIC PRESSURE (in. wg)									
	1.2		1.4		1.6		1.8		2.0	
	rpm	Vdc	rpm	Vdc	rpm	Vdc	rpm	Vdc	rpm	Vdc
3750	1727	7.8	—	—	—	—	—	—	—	—
4060	—	—	—	—	—	—	—	—	—	—
4375	—	—	—	—	—	—	—	—	—	—
4690	—	—	—	—	—	—	—	—	—	—
5000	—	—	—	—	—	—	—	—	—	—
5310	—	—	—	—	—	—	—	—	—	—
5625	—	—	—	—	—	—	—	—	—	—
5940	—	—	—	—	—	—	—	—	—	—
6250	—	—	—	—	—	—	—	—	—	—

Std/Med Static 1320-2200 rpm

Fan data (cont)

RGV150 — HIGH STATIC — 12.5 TON VERTICAL SUPPLY (RPM — VDC)

CFM	AVAILABLE EXTERNAL STATIC PRESSURE (in. wg)									
	0.2		0.4		0.6		0.8		1.0	
	rpm	Vdc	rpm	Vdc	rpm	Vdc	rpm	Vdc	rpm	Vdc
3750	1320	5.9	1416	6.4	1503	6.8	1583	7.2	1657	7.5
4060	1414	6.4	1504	6.8	1587	7.2	1664	7.5	1736	7.9
4375	1509	6.8	1594	7.2	1673	7.6	1747	7.9	1817	8.2
4690	1604	7.2	1685	7.6	1761	8.0	1832	8.3	1899	8.6
5000	1700	7.7	1777	8.0	1849	8.4	1918	8.7	1983	9.0
5310	1797	8.1	1870	8.5	1939	8.8	2005	9.1	2068	9.4
5625	1894	8.6	1964	8.9	2030	9.2	2093	9.5	2154	9.8
5940	1992	9.0	2058	9.3	2121	9.6	—	—	—	—
6250	2090	9.5	2153	9.8	—	—	—	—	—	—

CFM	AVAILABLE EXTERNAL STATIC PRESSURE (in. wg)									
	1.2		1.4		1.6		1.8		2.0	
	rpm	Vdc	rpm	Vdc	rpm	Vdc	rpm	Vdc	rpm	Vdc
3750	1727	7.8	1794	8.1	1857	8.4	1918	8.7	1976	9.0
4060	1804	8.2	1869	8.5	1930	8.8	1989	9.0	2046	9.3
4375	1883	8.5	1946	8.8	2005	9.1	2063	9.4	2119	9.6
4690	1963	8.9	2024	9.2	2082	9.5	2139	9.7	—	—
5000	2045	9.3	2104	9.6	—	—	—	—	—	—
5310	2128	9.7	—	—	—	—	—	—	—	—
5625	—	—	—	—	—	—	—	—	—	—
5940	—	—	—	—	—	—	—	—	—	—
6250	—	—	—	—	—	—	—	—	—	—

High Static 1320-2200 rpm

Fan data (cont)

RGV180 — 15 TON VERTICAL SUPPLY (RPM — BHP)

CFM	AVAILABLE EXTERNAL STATIC PRESSURE (in. wg)									
	0.2		0.4		0.6		0.8		1.0	
	rpm	bhp	rpm	bhp	rpm	bhp	rpm	bhp	rpm	bhp
4500	1251	1.02	1332	1.23	1412	1.47	1491	1.73	1569	2.02
4875	1343	1.26	1417	1.48	1491	1.72	1565	1.99	1637	2.28
5250	1435	1.52	1504	1.75	1573	2.00	1641	2.28	1709	2.57
5625	1528	1.81	1592	2.05	1657	2.31	1721	2.59	1785	2.89
6000	1621	2.13	1682	2.38	1742	2.64	1802	2.92	1862	3.23
6375	1715	2.47	1772	2.73	1829	3.00	1886	3.29	1942	3.59
6750	1810	2.86	1863	3.11	1917	3.39	1971	3.69	2024	3.99
7125	1905	3.29	1955	3.56	2006	3.84	2057	4.15	2108	4.46
7500	2000	3.82	2048	4.10	2096	4.40	2144	4.71	2193	5.04

CFM	AVAILABLE EXTERNAL STATIC PRESSURE (in. wg)									
	1.2		1.4		1.6		1.8		2.0	
	rpm	bhp	rpm	bhp	rpm	bhp	rpm	bhp	rpm	bhp
4500	1645	2.33	1719	2.65	1792	3.01	1862	3.37	1930	3.76
4875	1709	2.59	1779	2.93	1848	3.28	1915	3.65	1981	4.04
5250	1777	2.89	1843	3.22	1908	3.58	1973	3.95	2036	4.35
5625	1848	3.21	1911	3.55	1973	3.90	2034	4.28	2094	4.67
6000	1922	3.55	1981	3.88	2040	4.24	2098	4.61	2156	5.01
6375	1999	3.92	2055	4.26	2111	4.61	2166	4.98	—	—
6750	2078	4.32	2131	4.66	2184	5.02	—	—	—	—
7125	2158	4.79	—	—	—	—	—	—	—	—
7500	—	—	—	—	—	—	—	—	—	—

Std/Med Static 1251-2200 rpm, 3.0 Max bhp

High Static 1251-2200 rpm, 5.0 Max bhp

RGV180 — STANDARD/MEDIUM STATIC — 15 TON VERTICAL SUPPLY (RPM — VDC)

CFM	AVAILABLE EXTERNAL STATIC PRESSURE (in. wg)									
	0.2		0.4		0.6		0.8		1.0	
	rpm	Vdc	rpm	Vdc	rpm	Vdc	rpm	Vdc	rpm	Vdc
4500	1251	5.6	1332	6.0	1412	6.4	1491	6.7	1569	7.1
4875	1343	6.0	1417	6.4	1491	6.7	1565	7.1	1637	7.4
5250	1435	6.5	1504	6.8	1573	7.1	1641	7.4	1709	7.7
5625	1528	6.9	1592	7.2	1657	7.5	1721	7.8	1785	8.1
6000	1621	7.3	1682	7.6	1742	7.9	1802	8.2	—	—
6375	1715	7.8	1772	8.0	—	—	—	—	—	—
6750	1810	8.2	—	—	—	—	—	—	—	—
7125	—	—	—	—	—	—	—	—	—	—
7500	—	—	—	—	—	—	—	—	—	—

CFM	AVAILABLE EXTERNAL STATIC PRESSURE (in. wg)									
	1.2		1.4		1.6		1.8		2.0	
	rpm	Vdc	rpm	Vdc	rpm	Vdc	rpm	Vdc	rpm	Vdc
4500	1645	7.4	1719	7.8	—	—	—	—	—	—
4875	1709	7.7	1779	8.1	—	—	—	—	—	—
5250	1777	8.0	—	—	—	—	—	—	—	—
5625	—	—	—	—	—	—	—	—	—	—
6000	—	—	—	—	—	—	—	—	—	—
6375	—	—	—	—	—	—	—	—	—	—
6750	—	—	—	—	—	—	—	—	—	—
7125	—	—	—	—	—	—	—	—	—	—
7500	—	—	—	—	—	—	—	—	—	—

Std/Med Static 1251-2200 rpm

Fan data (cont)

RGV180 — HIGH STATIC — 15 TON VERTICAL SUPPLY (RPM — VDC)

CFM	AVAILABLE EXTERNAL STATIC PRESSURE (in. wg)									
	0.2		0.4		0.6		0.8		1.0	
	rpm	Vdc	rpm	Vdc	rpm	Vdc	rpm	Vdc	rpm	Vdc
4500	1251	5.6	1332	6.0	1412	6.4	1491	6.7	1569	7.1
4875	1343	6.0	1417	6.4	1491	6.7	1565	7.1	1637	7.4
5250	1435	6.5	1504	6.8	1573	7.1	1641	7.4	1709	7.7
5625	1528	6.9	1592	7.2	1657	7.5	1721	7.8	1785	8.1
6000	1621	7.3	1682	7.6	1742	7.9	1802	8.2	1862	8.4
6375	1715	7.8	1772	8.0	1829	8.3	1886	8.6	1942	8.8
6750	1810	8.2	1863	8.4	1917	8.7	1971	8.9	2024	9.2
7125	1905	8.6	1955	8.9	2006	9.1	2057	9.3	2108	9.6
7500	2000	9.1	2048	9.3	2096	9.5	2144	9.7	2193	10.0

CFM	AVAILABLE EXTERNAL STATIC PRESSURE (in. wg)									
	1.2		1.4		1.6		1.8		2.0	
	rpm	Vdc	rpm	Vdc	rpm	Vdc	rpm	Vdc	rpm	Vdc
4500	1645	7.4	1719	7.8	1792	8.1	1862	8.4	1930	8.8
4875	1709	7.7	1779	8.1	1848	8.4	1915	8.7	1981	9.0
5250	1777	8.0	1843	8.4	1908	8.7	1973	9.0	2036	9.2
5625	1848	8.4	1911	8.7	1973	9.0	2034	9.2	2094	9.5
6000	1922	8.7	1981	9.0	2040	9.3	2098	9.5	2156	9.8
6375	1999	9.1	2055	9.3	2111	9.6	2166	9.8	—	—
6750	2078	9.4	2131	9.7	2184	9.9	—	—	—	—
7125	2158	9.8	—	—	—	—	—	—	—	—
7500	—	—	—	—	—	—	—	—	—	—

High Static 1251-2200 rpm

Fan data (cont)

RGV090 — 7.5 TON HORIZONTAL SUPPLY (RPM — BHP)

CFM	AVAILABLE EXTERNAL STATIC PRESSURE (in. wg)									
	0.2		0.4		0.6		0.8		1.0	
	rpm	bhp	rpm	bhp	rpm	bhp	rpm	bhp	rpm	bhp
2250	987	0.36	1114	0.52	1227	0.70	1331	0.89	1428	1.10
2440	1047	0.43	1168	0.60	1277	0.78	1377	0.98	1471	1.20
2625	1109	0.51	1223	0.68	1328	0.87	1424	1.08	1515	1.30
2810	1171	0.60	1280	0.78	1380	0.97	1474	1.19	1561	1.41
3000	1234	0.69	1338	0.88	1434	1.08	1524	1.30	1609	1.53
3190	1298	0.79	1397	0.99	1490	1.20	1577	1.42	1659	1.65
3375	1363	0.90	1458	1.10	1546	1.32	1630	1.54	1710	1.78
3560	1428	1.02	1519	1.22	1604	1.44	1685	1.67	1762	1.91
3750	1494	1.14	1580	1.35	1663	1.57	1741	1.80	1816	2.05

CFM	AVAILABLE EXTERNAL STATIC PRESSURE (in. wg)									
	1.2		1.4		1.6		1.8		2.0	
	rpm	bhp	rpm	bhp	rpm	bhp	rpm	bhp	rpm	bhp
2250	1518	1.32	1602	1.55	1682	1.79	1757	2.04	1830	2.31
2440	1558	1.42	1641	1.66	1719	1.91	1794	2.17	1865	2.44
2625	1600	1.53	1681	1.77	1758	2.03	1831	2.29	1902	2.57
2810	1644	1.65	1723	1.90	1798	2.15	1871	2.43	1940	2.71
3000	1690	1.77	1767	2.02	1841	2.29	1911	2.56	1979	2.84
3190	1737	1.90	1813	2.16	1884	2.42	1954	2.70	2020	2.98
3375	1786	2.03	1859	2.29	1930	2.56	1997	2.84	2063	3.13
3560	1836	2.16	1908	2.43	1976	2.70	2042	2.98	—	—
3750	1888	2.30	1957	2.56	2024	2.83	2089	3.11	—	—

Std/Med Static 987-2000 rpm, 2.4 Max bhp

High Static 987-2200 rpm, 3.0 Max bhp

RGV090 — STANDARD/MEDIUM STATIC — 7.5 TON HORIZONTAL SUPPLY (RPM — VDC)

CFM	AVAILABLE EXTERNAL STATIC PRESSURE (in. wg)									
	0.2		0.4		0.6		0.8		1.0	
	rpm	Vdc	rpm	Vdc	rpm	Vdc	rpm	Vdc	rpm	Vdc
2250	987	4.8	1114	5.4	1227	6.0	1331	6.6	1428	7.1
2440	1047	5.1	1168	5.7	1277	6.3	1377	6.8	1471	7.3
2625	1109	5.4	1223	6.0	1328	6.5	1424	7.0	1515	7.5
2810	1171	5.7	1280	6.3	1380	6.8	1474	7.3	1561	7.7
3000	1234	6.1	1338	6.6	1434	7.1	1524	7.6	1609	8.0
3190	1298	6.4	1397	6.9	1490	7.4	1577	7.8	1659	8.2
3375	1363	6.7	1458	7.2	1546	7.7	1630	8.1	1710	8.5
3560	1428	7.1	1519	7.5	1604	8.0	1685	8.4	1762	8.8
3750	1494	7.4	1580	7.8	1663	8.3	1741	8.7	1816	9.1

CFM	AVAILABLE EXTERNAL STATIC PRESSURE (in. wg)									
	1.2		1.4		1.6		1.8		2.0	
	rpm	Vdc	rpm	Vdc	rpm	Vdc	rpm	Vdc	rpm	Vdc
2250	1518	7.5	1602	8.0	1682	8.4	1757	8.8	1830	9.1
2440	1558	7.7	1641	8.2	1719	8.6	1794	8.9	—	—
2625	1600	7.9	1681	8.4	1758	8.8	1831	9.1	—	—
2810	1644	8.2	1723	8.6	1798	9.0	—	—	—	—
3000	1690	8.4	1767	8.8	1841	9.2	—	—	—	—
3190	1737	8.6	1813	9.0	—	—	—	—	—	—
3375	1786	8.9	1859	9.3	—	—	—	—	—	—
3560	1836	9.2	—	—	—	—	—	—	—	—
3750	1888	9.4	—	—	—	—	—	—	—	—

Std/Med Static 987-2000 rpm

Fan data (cont)

RGV090 — HIGH STATIC — 7.5 TON HORIZONTAL SUPPLY (RPM — VDC)

CFM	AVAILABLE EXTERNAL STATIC PRESSURE (in. wg)									
	0.2		0.4		0.6		0.8		1.0	
	rpm	Vdc	rpm	Vdc	rpm	Vdc	rpm	Vdc	rpm	Vdc
2250	987	4.4	1114	5.0	1227	5.5	1331	6.0	1428	6.4
2440	1047	4.7	1168	5.2	1277	5.7	1377	6.2	1471	6.6
2625	1109	5.0	1223	5.5	1328	6.0	1424	6.4	1515	6.8
2810	1171	5.3	1280	5.8	1380	6.2	1474	6.6	1561	7.1
3000	1234	5.5	1338	6.0	1434	6.5	1524	6.9	1609	7.3
3190	1298	5.8	1397	6.3	1490	6.7	1577	7.1	1659	7.5
3375	1363	6.1	1458	6.6	1546	7.0	1630	7.4	1710	7.7
3560	1428	6.4	1519	6.9	1604	7.2	1685	7.6	1762	8.0
3750	1494	6.7	1580	7.1	1663	7.5	1741	7.9	1816	8.2

CFM	AVAILABLE EXTERNAL STATIC PRESSURE (in. wg)									
	1.2		1.4		1.6		1.8		2.0	
	rpm	Vdc	rpm	Vdc	rpm	Vdc	rpm	Vdc	rpm	Vdc
2250	1518	6.9	1602	7.2	1682	7.6	1757	8.0	1830	8.3
2440	1558	7.0	1641	7.4	1719	7.8	1794	8.1	1865	8.5
2625	1600	7.2	1681	7.6	1758	8.0	1831	8.3	1902	8.6
2810	1644	7.4	1723	7.8	1798	8.1	1871	8.5	1940	8.8
3000	1690	7.6	1767	8.0	1841	8.3	1911	8.7	1979	9.0
3190	1737	7.9	1813	8.2	1884	8.5	1954	8.9	2020	9.2
3375	1786	8.1	1859	8.4	1930	8.8	1997	9.1	2063	9.4
3560	1836	8.3	1908	8.7	1976	9.0	2042	9.3	—	—
3750	1888	8.6	1957	8.9	2024	9.2	2089	9.5	—	—

High Static 987-2200 rpm

Fan data (cont)

RGV102 — 8.5 TON HORIZONTAL SUPPLY (RPM — BHP)

CFM	AVAILABLE EXTERNAL STATIC PRESSURE (in. wg)									
	0.2		0.4		0.6		0.8		1.0	
	rpm	bhp	rpm	bhp	rpm	bhp	rpm	bhp	rpm	bhp
2550	1026	0.40	1140	0.55	1248	0.72	1349	0.91	1442	1.11
2760	1092	0.48	1199	0.63	1301	0.80	1398	1.00	1488	1.20
2975	1160	0.56	1261	0.72	1357	0.90	1449	1.10	1536	1.31
3190	1229	0.66	1323	0.83	1414	1.01	1502	1.21	1586	1.42
3400	1298	0.77	1387	0.94	1473	1.12	1557	1.33	1638	1.55
3610	1368	0.88	1452	1.06	1535	1.25	1614	1.45	1692	1.67
3825	1439	1.01	1519	1.19	1597	1.38	1673	1.58	1747	1.80
4040	1511	1.14	1586	1.32	1660	1.51	1733	1.72	1804	1.94
4250	1582	1.27	1654	1.45	1725	1.64	1795	1.85	1863	2.07

CFM	AVAILABLE EXTERNAL STATIC PRESSURE (in. wg)									
	1.2		1.4		1.6		1.8		2.0	
	rpm	bhp	rpm	bhp	rpm	bhp	rpm	bhp	rpm	bhp
2550	1529	1.32	1611	1.54	1688	1.77	1761	2.01	1830	2.26
2760	1573	1.42	1654	1.65	1730	1.89	1802	2.14	1870	2.39
2975	1619	1.53	1698	1.77	1773	2.01	1844	2.27	1911	2.52
3190	1667	1.65	1743	1.89	1817	2.14	1887	2.40	1954	2.66
3400	1716	1.78	1790	2.02	1862	2.27	1931	2.53	1997	2.80
3610	1767	1.91	1839	2.15	1909	2.40	1977	2.67	2041	2.94
3825	1820	2.04	1890	2.28	1958	2.54	2024	2.80	2087	3.07
4040	1874	2.17	1942	2.42	2008	2.67	2072	2.93	—	—
4250	1930	2.30	1996	2.55	2060	2.80	2122	3.06	—	—

Std/Med Static 1026-2000 rpm, 2.4 Max bhp

High Static 1026-2200 rpm, 3.0 Max bhp

RGV102 — STANDARD/MEDIUM STATIC — 8.5 TON HORIZONTAL SUPPLY (RPM — VDC)

CFM	AVAILABLE EXTERNAL STATIC PRESSURE (in. wg)									
	0.2		0.4		0.6		0.8		1.0	
	rpm	Vdc	rpm	Vdc	rpm	Vdc	rpm	Vdc	rpm	Vdc
2250	1026	5.0	1140	5.6	1248	6.1	1349	6.7	1442	7.1
2440	1092	5.3	1199	5.9	1301	6.4	1398	6.9	1488	7.4
2625	1160	5.7	1261	6.2	1357	6.7	1449	7.2	1536	7.6
2810	1229	6.0	1323	6.5	1414	7.0	1502	7.4	1586	7.9
3000	1298	6.4	1387	6.8	1473	7.3	1557	7.7	1638	8.1
3190	1368	6.7	1452	7.2	1535	7.6	1614	8.0	1692	8.4
3375	1439	7.1	1519	7.5	1597	7.9	1673	8.3	1747	8.7
3560	1511	7.5	1586	7.9	1660	8.3	1733	8.6	1804	9.0
3750	1582	7.9	1654	8.2	1725	8.6	1795	8.9	1863	9.3

CFM	AVAILABLE EXTERNAL STATIC PRESSURE (in. wg)									
	1.2		1.4		1.6		1.8		2.0	
	rpm	Vdc	rpm	Vdc	rpm	Vdc	rpm	Vdc	rpm	Vdc
2550	1529	7.6	1611	8.0	1688	8.4	1761	8.8	1830	9.1
2760	1573	7.8	1654	8.2	1730	8.6	1802	9.0	1870	9.3
2975	1619	8.0	1698	8.4	1773	8.8	1844	9.2	—	—
3190	1667	8.3	1743	8.7	1817	9.1	1887	9.4	—	—
3400	1716	8.5	1790	8.9	1862	9.3	—	—	—	—
3610	1767	8.8	1839	9.2	1909	9.5	—	—	—	—
3825	1820	9.1	1890	9.4	—	—	—	—	—	—
4040	1874	9.4	—	—	—	—	—	—	—	—
4250	1930	9.6	—	—	—	—	—	—	—	—

Std/Med Static 1026-2000 rpm

Fan data (cont)

RGV102 — HIGH STATIC — 8.5 TON HORIZONTAL SUPPLY (RPM — VDC)

CFM	AVAILABLE EXTERNAL STATIC PRESSURE (in. wg)									
	0.2		0.4		0.6		0.8		1.0	
	rpm	Vdc	rpm	Vdc	rpm	Vdc	rpm	Vdc	rpm	Vdc
2550	1026	4.6	1140	5.1	1248	5.6	1349	6.1	1442	6.5
2760	1092	4.9	1199	5.4	1301	5.9	1398	6.3	1488	6.7
2975	1160	5.2	1261	5.7	1357	6.1	1449	6.5	1536	6.9
3190	1229	5.5	1323	6.0	1414	6.4	1502	6.8	1586	7.2
3400	1298	5.8	1387	6.2	1473	6.6	1557	7.0	1638	7.4
3610	1368	6.2	1452	6.5	1535	6.9	1614	7.3	1692	7.7
3825	1439	6.5	1519	6.9	1597	7.2	1673	7.6	1747	7.9
4040	1511	6.8	1586	7.2	1660	7.5	1733	7.8	1804	8.2
4250	1582	7.1	1654	7.5	1725	7.8	1795	8.1	1863	8.4

CFM	AVAILABLE EXTERNAL STATIC PRESSURE (in. wg)									
	1.2		1.4		1.6		1.8		2.0	
	rpm	Vdc	rpm	Vdc	rpm	Vdc	rpm	Vdc	rpm	Vdc
2550	1529	6.9	1611	7.3	1688	7.6	1761	8.0	1830	8.3
2760	1573	7.1	1654	7.5	1730	7.8	1802	8.2	1870	8.5
2975	1619	7.3	1698	7.7	1773	8.0	1844	8.4	1911	8.7
3190	1667	7.5	1743	7.9	1817	8.2	1887	8.6	1954	8.9
3400	1716	7.8	1790	8.1	1862	8.4	1931	8.8	1997	9.1
3610	1767	8.0	1839	8.3	1909	8.7	1977	9.0	2041	9.3
3825	1820	8.2	1890	8.6	1958	8.9	2024	9.2	2087	9.5
4040	1874	8.5	1942	8.8	2008	9.1	2072	9.4	—	—
4250	1930	8.8	1996	9.1	2060	9.4	2122	9.6	—	—

High Static 1026-2200 rpm

Fan data (cont)

RGV120 — 10 TON HORIZONTAL SUPPLY (RPM — BHP)

CFM	AVAILABLE EXTERNAL STATIC PRESSURE (in. wg)									
	0.2		0.4		0.6		0.8		1.0	
	rpm	bhp	rpm	bhp	rpm	bhp	rpm	bhp	rpm	bhp
3000	1188	0.62	1288	0.78	1384	0.97	1475	1.18	1562	1.40
3250	1271	0.75	1364	0.92	1454	1.12	1540	1.33	1623	1.55
3500	1355	0.89	1441	1.07	1526	1.27	1608	1.49	1687	1.72
3750	1439	1.05	1521	1.24	1600	1.45	1678	1.67	1753	1.90
4000	1525	1.23	1601	1.42	1676	1.63	1750	1.86	1822	2.10
4250	1611	1.42	1683	1.62	1754	1.83	1824	2.06	1892	2.30
4500	1697	1.62	1765	1.82	1833	2.04	1899	2.27	1965	2.51
4750	1784	1.83	1849	2.03	1913	2.25	1976	2.48	2038	2.72
5000	1872	2.04	1933	2.25	1994	2.47	2054	2.70	2114	2.94

CFM	AVAILABLE EXTERNAL STATIC PRESSURE (in. wg)									
	1.2		1.4		1.6		1.8		2.0	
	rpm	bhp	rpm	bhp	rpm	bhp	rpm	bhp	rpm	bhp
3000	1644	1.63	1722	1.87	1796	2.13	1866	2.38	1933	2.65
3250	1702	1.79	1778	2.04	1850	2.30	1919	2.57	1985	2.84
3500	1763	1.96	1836	2.22	1906	2.48	1974	2.76	2039	3.04
3750	1826	2.15	1897	2.41	1965	2.68	2031	2.96	2094	3.24
4000	1892	2.35	1960	2.61	2026	2.89	2090	3.17	2152	3.46
4250	1959	2.56	2025	2.82	2088	3.09	2150	3.38	—	—
4500	2029	2.77	2092	3.03	2153	3.31	—	—	—	—
4750	2100	2.98	2160	3.24	—	—	—	—	—	—
5000	2173	3.19	—	—	—	—	—	—	—	—

Std/Med Static 1188-2000 rpm, 2.4 Max bhp

High Static 1188-2200 rpm, 5.0 Max bhp

RGV120 — STANDARD/MEDIUM STATIC — 10 TON HORIZONTAL SUPPLY (RPM — VDC)

CFM	AVAILABLE EXTERNAL STATIC PRESSURE (in. wg)									
	0.2		0.4		0.6		0.8		1.0	
	rpm	Vdc	rpm	Vdc	rpm	Vdc	rpm	Vdc	rpm	Vdc
3000	1188	5.8	1288	6.3	1384	6.8	1475	7.3	1562	7.7
3250	1271	6.3	1364	6.7	1454	7.2	1540	7.6	1623	8.1
3500	1355	6.7	1441	7.1	1526	7.6	1608	8.0	1687	8.4
3750	1439	7.1	1521	7.5	1600	7.9	1678	8.3	1753	8.7
4000	1525	7.6	1601	7.9	1676	8.3	1750	8.7	1822	9.1
4250	1611	8.0	1683	8.4	1754	8.7	1824	9.1	1892	9.4
4500	1697	8.4	1765	8.8	1833	9.1	1899	9.5	—	—
4750	1784	8.9	1849	9.2	1913	9.6	—	—	—	—
5000	1872	9.3	1933	9.7	—	—	—	—	—	—

CFM	AVAILABLE EXTERNAL STATIC PRESSURE (in. wg)									
	1.2		1.4		1.6		1.8		2.0	
	rpm	Vdc	rpm	Vdc	rpm	Vdc	rpm	Vdc	rpm	Vdc
3000	1644	8.2	1722	8.6	1796	9.0	1866	9.3	—	—
3250	1702	8.5	1778	8.9	1850	9.2	—	—	—	—
3500	1763	8.8	1836	9.2	1906	9.5	—	—	—	—
3750	1826	9.1	1897	9.5	—	—	—	—	—	—
4000	1892	9.4	—	—	—	—	—	—	—	—
4250	—	—	—	—	—	—	—	—	—	—
4500	—	—	—	—	—	—	—	—	—	—
4750	—	—	—	—	—	—	—	—	—	—
5000	—	—	—	—	—	—	—	—	—	—

Std/Med Static 1188-2000 rpm

Fan data (cont)

RGV120 — HIGH STATIC — 10 TON HORIZONTAL SUPPLY (RPM — VDC)

CFM	AVAILABLE EXTERNAL STATIC PRESSURE (in. wg)									
	0.2		0.4		0.6		0.8		1.0	
	rpm	Vdc	rpm	Vdc	rpm	Vdc	rpm	Vdc	rpm	Vdc
3000	1188	5.3	1288	5.8	1384	6.2	1475	6.7	1562	7.1
3250	1271	5.7	1364	6.1	1454	6.6	1540	7.0	1623	7.3
3500	1355	6.1	1441	6.5	1526	6.9	1608	7.3	1687	7.6
3750	1439	6.5	1521	6.9	1600	7.2	1678	7.6	1753	7.9
4000	1525	6.9	1601	7.2	1676	7.6	1750	7.9	1822	8.3
4250	1611	7.3	1683	7.6	1754	7.9	1824	8.3	1892	8.6
4500	1697	7.7	1765	8.0	1833	8.3	1899	8.6	1965	8.9
4750	1784	8.1	1849	8.4	1913	8.7	1976	9.0	2038	9.3
5000	1872	8.5	1933	8.8	1994	9.0	2054	9.3	2114	9.6

CFM	AVAILABLE EXTERNAL STATIC PRESSURE (in. wg)									
	1.2		1.4		1.6		1.8		2.0	
	rpm	Vdc	rpm	Vdc	rpm	Vdc	rpm	Vdc	rpm	Vdc
3000	1644	7.4	1722	7.8	1796	8.1	1866	8.5	1933	8.8
3250	1702	7.7	1778	8.1	1850	8.4	1919	8.7	1985	9.0
3500	1763	8.0	1836	8.3	1906	8.6	1974	9.0	2039	9.3
3750	1826	8.3	1897	8.6	1965	8.9	2031	9.2	2094	9.5
4000	1892	8.6	1960	8.9	2026	9.2	2090	9.5	2152	9.8
4250	1959	8.9	2025	9.2	2088	9.5	2150	9.8	—	—
4500	2029	9.2	2092	9.5	2153	9.8	—	—	—	—
4750	2100	9.5	2160	9.8	—	—	—	—	—	—
5000	2173	9.9	—	—	—	—	—	—	—	—

High Static 1188-2200 rpm

Fan data (cont)

RGV150 — 12.5 TON HORIZONTAL SUPPLY (RPM — BHP)

CFM	AVAILABLE EXTERNAL STATIC PRESSURE (in. wg)									
	0.2		0.4		0.6		0.8		1.0	
	rpm	bhp	rpm	bhp	rpm	bhp	rpm	bhp	rpm	bhp
3750	1198	0.90	1298	1.15	1393	1.42	1483	1.72	1566	2.02
4060	1282	1.10	1374	1.36	1464	1.64	1550	1.95	1631	2.27
4375	1367	1.33	1453	1.60	1537	1.90	1619	2.21	1697	2.55
4690	1453	1.59	1533	1.87	1613	2.18	1690	2.51	1765	2.86
5000	1540	1.89	1615	2.17	1690	2.49	1763	2.83	1835	3.19
5310	1628	2.21	1697	2.50	1768	2.83	1838	3.18	1906	3.55
5625	1715	2.56	1781	2.86	1847	3.19	1914	3.55	1979	3.93
5940	1804	2.94	1866	3.25	1929	3.59	1992	3.95	2054	4.33
6250	1892	3.34	1951	3.66	2011	4.01	2071	4.37	2131	4.77

CFM	AVAILABLE EXTERNAL STATIC PRESSURE (in. wg)									
	1.2		1.4		1.6		1.8		2.0	
	rpm	bhp	rpm	bhp	rpm	bhp	rpm	bhp	rpm	bhp
3750	1644	2.34	1718	2.67	1787	3.00	1854	3.35	1917	3.70
4060	1707	2.61	1778	2.95	1847	3.30	1912	3.66	1974	4.03
4375	1771	2.90	1841	3.26	1908	3.63	1971	4.00	2033	4.39
4690	1836	3.22	1905	3.59	1970	3.97	2033	4.37	2093	4.76
5000	1904	3.56	1970	3.95	2034	4.34	2095	4.75	2154	5.16
5310	1973	3.93	2037	4.33	2099	4.74	2159	5.15	—	—
5625	2043	4.32	2106	4.73	2166	5.15	—	—	—	—
5940	2116	4.74	2176	5.15	—	—	—	—	—	—
6250	2189	5.17	—	—	—	—	—	—	—	—

Std/Med Static 1198-2200 rpm, 3.0 Max bhp

High Static 1198-2200 rpm, 5.0 Max bhp

RGV150 — STANDARD/MEDIUM STATIC — 12.5 TON HORIZONTAL SUPPLY (RPM — VDC)

CFM	AVAILABLE EXTERNAL STATIC PRESSURE (in. wg)									
	0.2		0.4		0.6		0.8		1.0	
	rpm	Vdc	rpm	Vdc	rpm	Vdc	rpm	Vdc	rpm	Vdc
3750	1198	5.4	1298	5.8	1393	6.3	1483	6.7	1566	7.1
4060	1282	5.8	1374	6.2	1464	6.6	1550	7.0	1631	7.4
4375	1367	6.2	1453	6.6	1537	6.9	1619	7.3	1697	7.7
4690	1453	6.6	1533	6.9	1613	7.3	1690	7.6	1765	8.0
5000	1540	7.0	1615	7.3	1690	7.6	1763	8.0	—	—
5310	1628	7.4	1697	7.7	1768	8.0	—	—	—	—
5625	1715	7.8	1781	8.1	—	—	—	—	—	—
5940	1804	8.2	—	—	—	—	—	—	—	—
6250	—	—	—	—	—	—	—	—	—	—

CFM	AVAILABLE EXTERNAL STATIC PRESSURE (in. wg)									
	1.2		1.4		1.6		1.8		2.0	
	rpm	Vdc	rpm	Vdc	rpm	Vdc	rpm	Vdc	rpm	Vdc
3750	1644	7.4	1718	7.8	1787	8.1	—	—	—	—
4060	1707	7.7	1778	8.1	—	—	—	—	—	—
4375	1771	8.0	—	—	—	—	—	—	—	—
4690	—	—	—	—	—	—	—	—	—	—
5000	—	—	—	—	—	—	—	—	—	—
5310	—	—	—	—	—	—	—	—	—	—
5625	—	—	—	—	—	—	—	—	—	—
5940	—	—	—	—	—	—	—	—	—	—
6250	—	—	—	—	—	—	—	—	—	—

Std/Med Static 1198-2200 rpm

Fan data (cont)

RGV150 — HIGH STATIC — 12.5 TON HORIZONTAL SUPPLY (RPM — VDC)

CFM	AVAILABLE EXTERNAL STATIC PRESSURE (in. wg)									
	0.2		0.4		0.6		0.8		1.0	
	rpm	Vdc	rpm	Vdc	rpm	Vdc	rpm	Vdc	rpm	Vdc
3750	1198	5.4	1298	5.8	1393	6.3	1483	6.7	1566	7.1
4060	1282	5.8	1374	6.2	1464	6.6	1550	7.0	1631	7.4
4375	1367	6.2	1453	6.6	1537	6.9	1619	7.3	1697	7.7
4690	1453	6.6	1533	6.9	1613	7.3	1690	7.6	1765	8.0
5000	1540	7.0	1615	7.3	1690	7.6	1763	8.0	1835	8.3
5310	1628	7.4	1697	7.7	1768	8.0	1838	8.3	1906	8.6
5625	1715	7.8	1781	8.1	1847	8.4	1914	8.7	1979	9.0
5940	1804	8.2	1866	8.5	1929	8.7	1992	9.0	2054	9.3
6250	1892	8.6	1951	8.9	2011	9.1	2071	9.4	2131	9.7

CFM	AVAILABLE EXTERNAL STATIC PRESSURE (in. wg)									
	1.2		1.4		1.6		1.8		2.0	
	rpm	Vdc	rpm	Vdc	rpm	Vdc	rpm	Vdc	rpm	Vdc
3750	1644	7.4	1718	7.8	1787	8.1	1854	8.4	1917	8.7
4060	1707	7.7	1778	8.1	1847	8.4	1912	8.7	1974	9.0
4375	1771	8.0	1841	8.3	1908	8.7	1971	8.9	2033	9.2
4690	1836	8.3	1905	8.6	1970	8.9	2033	9.2	2093	9.5
5000	1904	8.6	1970	8.9	2034	9.2	2095	9.5	2154	9.8
5310	1973	9.0	2037	9.2	2099	9.5	2159	9.8	—	—
5625	2043	9.3	2106	9.6	2166	9.8	—	—	—	—
5940	2116	9.6	2176	9.9	—	—	—	—	—	—
6250	2189	9.9	—	—	—	—	—	—	—	—

High Static 1198-2200 rpm

Fan data (cont)

RGV180 — 15 TON HORIZONTAL SUPPLY (RPM — BHP)

CFM	AVAILABLE EXTERNAL STATIC PRESSURE (in. wg)									
	0.2		0.4		0.6		0.8		1.0	
	rpm	bhp	rpm	bhp	rpm	bhp	rpm	bhp	rpm	bhp
4500	1248	1.02	1328	1.22	1408	1.46	1487	1.72	1566	2.01
4875	1339	1.25	1413	1.47	1487	1.71	1561	1.98	1634	2.27
5250	1431	1.51	1500	1.74	1568	1.98	1637	2.26	1705	2.55
5625	1524	1.80	1588	2.03	1652	2.29	1716	2.57	1780	2.87
6000	1617	2.11	1677	2.36	1737	2.62	1797	2.90	1857	3.20
6375	1711	2.46	1767	2.71	1824	2.98	1881	3.26	1937	3.56
6750	1805	2.83	1858	3.09	1912	3.37	1965	3.65	2019	3.96
7125	1899	3.26	1950	3.53	2001	3.82	2051	4.11	2102	4.42
7500	1994	3.79	2042	4.07	2090	4.36	2139	4.68	2187	5.00

CFM	AVAILABLE EXTERNAL STATIC PRESSURE (in. wg)									
	1.2		1.4		1.6		1.8		2.0	
	rpm	bhp	rpm	bhp	rpm	bhp	rpm	bhp	rpm	bhp
4500	1642	2.31	1717	2.64	1790	3.00	1861	3.37	1929	3.75
4875	1705	2.58	1776	2.91	1845	3.26	1913	3.64	1979	4.03
5250	1773	2.87	1839	3.20	1905	3.56	1970	3.94	2033	4.33
5625	1843	3.18	1906	3.52	1968	3.87	2030	4.25	2090	4.64
6000	1917	3.52	1976	3.86	2035	4.21	2094	4.59	2151	4.97
6375	1993	3.88	2050	4.22	2105	4.57	2161	4.95	—	—
6750	2072	4.28	2125	4.62	2178	4.98	—	—	—	—
7125	2153	4.75	—	—	—	—	—	—	—	—
7500	—	—	—	—	—	—	—	—	—	—

Std/Med Static 1248-2200 rpm, 3.0 Max bhp

High Static 1248-2200 rpm, 5.0 Max bhp

RGV180 — STANDARD/MEDIUM STATIC — 15 TON HORIZONTAL SUPPLY (RPM — VDC)

CFM	AVAILABLE EXTERNAL STATIC PRESSURE (in. wg)									
	0.2		0.4		0.6		0.8		1.0	
	rpm	Vdc	rpm	Vdc	rpm	Vdc	rpm	Vdc	rpm	Vdc
4500	1248	5.6	1328	6.0	1408	6.3	1487	6.7	1566	7.1
4875	1339	6.0	1413	6.4	1487	6.7	1561	7.1	1634	7.4
5250	1431	6.5	1500	6.8	1568	7.1	1637	7.4	1705	7.7
5625	1524	6.9	1588	7.2	1652	7.5	1716	7.8	1780	8.1
6000	1617	7.3	1677	7.6	1737	7.9	1797	8.1	—	—
6375	1711	7.7	1767	8.0	1824	8.3	—	—	—	—
6750	1805	8.2	—	—	—	—	—	—	—	—
7125	—	—	—	—	—	—	—	—	—	—
7500	—	—	—	—	—	—	—	—	—	—

CFM	AVAILABLE EXTERNAL STATIC PRESSURE (in. wg)									
	1.2		1.4		1.6		1.8		2.0	
	rpm	Vdc	rpm	Vdc	rpm	Vdc	rpm	Vdc	rpm	Vdc
4500	1642	7.4	1717	7.8	—	—	—	—	—	—
4875	1705	7.7	1776	8.0	—	—	—	—	—	—
5250	1773	8.0	—	—	—	—	—	—	—	—
5625	—	—	—	—	—	—	—	—	—	—
6000	—	—	—	—	—	—	—	—	—	—
6375	—	—	—	—	—	—	—	—	—	—
6750	—	—	—	—	—	—	—	—	—	—
7125	—	—	—	—	—	—	—	—	—	—
7500	—	—	—	—	—	—	—	—	—	—

Std/Med Static 1248-2200 rpm

Fan data (cont)

RGV180 — HIGH STATIC — 15 TON HORIZONTAL SUPPLY (RPM — VDC)

CFM	AVAILABLE EXTERNAL STATIC PRESSURE (in. wg)									
	0.2		0.4		0.6		0.8		1.0	
	rpm	Vdc	rpm	Vdc	rpm	Vdc	rpm	Vdc	rpm	Vdc
4500	1248	5.6	1328	6.0	1408	6.3	1487	6.7	1566	7.1
4875	1339	6.0	1413	6.4	1487	6.7	1561	7.1	1634	7.4
5250	1431	6.5	1500	6.8	1568	7.1	1637	7.4	1705	7.7
5625	1524	6.9	1588	7.2	1652	7.5	1716	7.8	1780	8.1
6000	1617	7.3	1677	7.6	1737	7.9	1797	8.1	1857	8.4
6375	1711	7.7	1767	8.0	1824	8.3	1881	8.5	1937	8.8
6750	1805	8.2	1858	8.4	1912	8.7	1965	8.9	2019	9.2
7125	1899	8.6	1950	8.8	2001	9.1	2051	9.3	2102	9.5
7500	1994	9.0	2042	9.3	2090	9.5	2139	9.7	2187	9.9

CFM	AVAILABLE EXTERNAL STATIC PRESSURE (in. wg)									
	1.2		1.4		1.6		1.8		2.0	
	rpm	Vdc	rpm	Vdc	rpm	Vdc	rpm	Vdc	rpm	Vdc
4500	1642	7.4	1717	7.8	1790	8.1	1861	8.4	1929	8.7
4875	1705	7.7	1776	8.0	1845	8.4	1913	8.7	1979	9.0
5250	1773	8.0	1839	8.3	1905	8.6	1970	8.9	2033	9.2
5625	1843	8.4	1906	8.6	1968	8.9	2030	9.2	2090	9.5
6000	1917	8.7	1976	9.0	2035	9.2	2094	9.5	2151	9.8
6375	1993	9.0	2050	9.3	2105	9.6	2161	9.8	—	—
6750	2072	9.4	2125	9.7	2178	9.9	—	—	—	—
7125	2153	9.8	—	—	—	—	—	—	—	—
7500	—	—	—	—	—	—	—	—	—	—

High Static 1248-2200 rpm

Fan data (cont)

RAV090 — 7.5 TON VERTICAL SUPPLY (RPM — BHP)

CFM	AVAILABLE EXTERNAL STATIC PRESSURE (in. wg)									
	0.2		0.4		0.6		0.8		1.0	
	rpm	bhp	rpm	bhp	rpm	bhp	rpm	bhp	rpm	bhp
2250	970	0.34	1102	0.50	1216	0.68	1319	0.86	1414	1.07
2440	1031	0.41	1157	0.58	1267	0.76	1367	0.96	1459	1.17
2625	1092	0.49	1213	0.67	1320	0.86	1416	1.06	1506	1.28
2810	1155	0.57	1271	0.76	1374	0.96	1467	1.17	1554	1.39
3000	1219	0.66	1330	0.86	1429	1.07	1520	1.29	1605	1.52
3190	1284	0.77	1390	0.97	1486	1.19	1574	1.41	1656	1.64
3375	1349	0.87	1451	1.09	1544	1.31	1629	1.54	1709	1.78
3560	1415	0.99	1513	1.21	1603	1.44	1686	1.68	1764	1.92
3750	1481	1.11	1576	1.34	1662	1.57	1743	1.81	1819	2.06

CFM	AVAILABLE EXTERNAL STATIC PRESSURE (in. wg)									
	1.2		1.4		1.6		1.8		2.0	
	rpm	bhp	rpm	bhp	rpm	bhp	rpm	bhp	rpm	bhp
2250	1502	1.28	1585	1.50	1664	1.74	1739	1.98	1810	2.23
2440	1545	1.38	1626	1.61	1703	1.85	1777	2.11	1847	2.37
2625	1589	1.50	1669	1.74	1745	1.98	1817	2.24	1886	2.51
2810	1636	1.62	1713	1.86	1788	2.12	1858	2.38	1926	2.65
3000	1684	1.75	1760	2.00	1832	2.26	1901	2.52	1968	2.80
3190	1734	1.89	1808	2.14	1878	2.40	1946	2.67	2012	2.95
3375	1785	2.03	1857	2.28	1926	2.55	1992	2.82	2057	3.10
3560	1837	2.17	1908	2.43	1975	2.69	2040	2.97	—	—
3750	1891	2.31	1960	2.57	2026	2.84	2089	3.11	—	—

Std/Med Static 970-2000 rpm, 2.4 Max bhp

High Static 970-2200 rpm, 3.0 Max bhp

RAV090 — STANDARD/MEDIUM STATIC — 7.5 TON VERTICAL SUPPLY (RPM — VDC)

CFM	AVAILABLE EXTERNAL STATIC PRESSURE (in. wg)									
	0.2		0.4		0.6		0.8		1.0	
	rpm	Vdc	rpm	Vdc	rpm	Vdc	rpm	Vdc	rpm	Vdc
2250	970	4.7	1102	5.4	1216	6.0	1319	6.5	1414	7.0
2440	1031	5.0	1157	5.7	1267	6.2	1367	6.7	1459	7.2
2625	1092	5.3	1213	6.0	1320	6.5	1416	7.0	1506	7.5
2810	1155	5.7	1271	6.3	1374	6.8	1467	7.3	1554	7.7
3000	1219	6.0	1330	6.6	1429	7.1	1520	7.5	1605	8.0
3190	1284	6.3	1390	6.9	1486	7.4	1574	7.8	1656	8.2
3375	1349	6.7	1451	7.2	1544	7.7	1629	8.1	1709	8.5
3560	1415	7.0	1513	7.5	1603	8.0	1686	8.4	1764	8.8
3750	1481	7.3	1576	7.8	1662	8.3	1743	8.7	1819	9.1

CFM	AVAILABLE EXTERNAL STATIC PRESSURE (in. wg)									
	1.2		1.4		1.6		1.8		2.0	
	rpm	Vdc	rpm	Vdc	rpm	Vdc	rpm	Vdc	rpm	Vdc
2250	1502	7.4	1585	7.9	1664	8.3	1739	8.7	1810	9.0
2440	1545	7.7	1626	8.1	1703	8.5	1777	8.9	1847	9.2
2625	1589	7.9	1669	8.3	1745	8.7	1817	9.1	—	—
2810	1636	8.1	1713	8.5	1788	8.9	1858	9.3	—	—
3000	1684	8.4	1760	8.8	1832	9.1	—	—	—	—
3190	1734	8.6	1808	9.0	1878	9.4	—	—	—	—
3375	1785	8.9	1857	9.3	—	—	—	—	—	—
3560	1837	9.2	—	—	—	—	—	—	—	—
3750	1891	9.4	—	—	—	—	—	—	—	—

Std/Med Static 970-2000 rpm

Fan data (cont)

RAV090 — HIGH STATIC — 7.5 TON VERTICAL SUPPLY (RPM — VDC)

CFM	AVAILABLE EXTERNAL STATIC PRESSURE (in. wg)									
	0.2		0.4		0.6		0.8		1.0	
	rpm	Vdc	rpm	Vdc	rpm	Vdc	rpm	Vdc	rpm	Vdc
2250	970	4.3	1102	4.9	1216	5.5	1319	5.9	1414	6.4
2440	1031	4.6	1157	5.2	1267	5.7	1367	6.2	1459	6.6
2625	1092	4.9	1213	5.4	1320	5.9	1416	6.4	1506	6.8
2810	1155	5.2	1271	5.7	1374	6.2	1467	6.6	1554	7.0
3000	1219	5.5	1330	6.0	1429	6.4	1520	6.9	1605	7.3
3190	1284	5.8	1390	6.3	1486	6.7	1574	7.1	1656	7.5
3375	1349	6.1	1451	6.5	1544	7.0	1629	7.4	1709	7.7
3560	1415	6.4	1513	6.8	1603	7.2	1686	7.6	1764	8.0
3750	1481	6.7	1576	7.1	1662	7.5	1743	7.9	1819	8.2

CFM	AVAILABLE EXTERNAL STATIC PRESSURE (in. wg)									
	1.2		1.4		1.6		1.8		2.0	
	rpm	Vdc	rpm	Vdc	rpm	Vdc	rpm	Vdc	rpm	Vdc
2250	1502	6.8	1585	7.2	1664	7.5	1739	7.9	1810	8.2
2440	1545	7.0	1626	7.4	1703	7.7	1777	8.0	1847	8.4
2625	1589	7.2	1669	7.5	1745	7.9	1817	8.2	1886	8.6
2810	1636	7.4	1713	7.8	1788	8.1	1858	8.4	1926	8.7
3000	1684	7.6	1760	8.0	1832	8.3	1901	8.6	1968	8.9
3190	1734	7.8	1808	8.2	1878	8.5	1946	8.8	2012	9.1
3375	1785	8.1	1857	8.4	1926	8.7	1992	9.0	2057	9.3
3560	1837	8.3	1908	8.7	1975	9.0	2040	9.3	—	—
3750	1891	8.6	1960	8.9	2026	9.2	2089	9.5	—	—

High Static 970-2200 rpm

Fan data (cont)

RAV102 — 8.5 TON VERTICAL SUPPLY (RPM — BHP)

CFM	AVAILABLE EXTERNAL STATIC PRESSURE (in. wg)									
	0.2		0.4		0.6		0.8		1.0	
	rpm	bhp	rpm	bhp	rpm	bhp	rpm	bhp	rpm	bhp
2550	1015	0.39	1128	0.53	1233	0.69	1330	0.87	1421	1.06
2760	1084	0.47	1190	0.62	1289	0.78	1382	0.96	1470	1.16
2975	1154	0.56	1253	0.71	1348	0.89	1437	1.07	1521	1.27
3190	1225	0.66	1319	0.82	1408	1.00	1493	1.19	1574	1.39
3400	1297	0.77	1386	0.94	1470	1.12	1551	1.31	1629	1.52
3610	1370	0.89	1453	1.06	1534	1.25	1612	1.45	1687	1.66
3825	1443	1.02	1522	1.19	1599	1.38	1673	1.58	1745	1.80
4040	1517	1.15	1592	1.33	1665	1.52	1736	1.73	1806	1.94
4250	1591	1.29	1663	1.47	1733	1.67	1801	1.87	1867	2.09

CFM	AVAILABLE EXTERNAL STATIC PRESSURE (in. wg)									
	1.2		1.4		1.6		1.8		2.0	
	rpm	bhp	rpm	bhp	rpm	bhp	rpm	bhp	rpm	bhp
2550	1506	1.26	1586	1.47	1662	1.69	1734	1.92	1802	2.16
2760	1552	1.37	1630	1.58	1705	1.81	1776	2.05	1843	2.29
2975	1601	1.48	1677	1.70	1750	1.94	1819	2.17	1886	2.42
3190	1652	1.61	1726	1.84	1796	2.07	1864	2.31	1930	2.57
3400	1704	1.74	1776	1.97	1845	2.21	1911	2.45	1975	2.71
3610	1759	1.88	1828	2.11	1895	2.35	1960	2.60	2023	2.86
3825	1815	2.02	1882	2.25	1947	2.50	2011	2.75	2072	3.01
4040	1873	2.17	1938	2.40	2001	2.64	2063	2.90	2122	3.15
4250	1932	2.31	1995	2.54	2056	2.78	2116	3.04	—	—

Std/Med Static 1015-2000 rpm, 2.4 Max bhp

High Static 1015-2200 rpm, 3.0 Max bhp

RAV102 — STANDARD/MEDIUM STATIC — 8.5 TON VERTICAL SUPPLY (RPM — VDC)

CFM	AVAILABLE EXTERNAL STATIC PRESSURE (in. wg)									
	0.2		0.4		0.6		0.8		1.0	
	rpm	Vdc	rpm	Vdc	rpm	Vdc	rpm	Vdc	rpm	Vdc
2550	1015	4.9	1128	5.5	1233	6.1	1330	6.6	1421	7.0
2760	1084	5.3	1190	5.8	1289	6.3	1382	6.8	1470	7.3
2975	1154	5.6	1253	6.2	1348	6.6	1437	7.1	1521	7.5
3190	1225	6.0	1319	6.5	1408	7.0	1493	7.4	1574	7.8
3400	1297	6.4	1386	6.8	1470	7.3	1551	7.7	1629	8.1
3610	1370	6.8	1453	7.2	1534	7.6	1612	8.0	1687	8.4
3825	1443	7.1	1522	7.5	1599	7.9	1673	8.3	1745	8.7
4040	1517	7.5	1592	7.9	1665	8.3	1736	8.6	1806	9.0
4250	1591	7.9	1663	8.3	1733	8.6	1801	9.0	1867	9.3

CFM	AVAILABLE EXTERNAL STATIC PRESSURE (in. wg)									
	1.2		1.4		1.6		1.8		2.0	
	rpm	Vdc	rpm	Vdc	rpm	Vdc	rpm	Vdc	rpm	Vdc
2550	1506	7.5	1586	7.9	1662	8.3	1734	8.6	1802	9.0
2760	1552	7.7	1630	8.1	1705	8.5	1776	8.8	1843	9.2
2975	1601	7.9	1677	8.3	1750	8.7	1819	9.1	—	—
3190	1652	8.2	1726	8.6	1796	9.0	—	—	—	—
3400	1704	8.5	1776	8.8	1845	9.2	—	—	—	—
3610	1759	8.8	1828	9.1	1895	9.5	—	—	—	—
3825	1815	9.0	1882	9.4	—	—	—	—	—	—
4040	1873	9.3	—	—	—	—	—	—	—	—
4250	1932	9.7	—	—	—	—	—	—	—	—

Std/Med Static 1015-2000 rpm

Fan data (cont)

RAV102 — HIGH STATIC — 8.5 TON VERTICAL SUPPLY (RPM — VDC)

CFM	AVAILABLE EXTERNAL STATIC PRESSURE (in. wg)									
	0.2		0.4		0.6		0.8		1.0	
	rpm	Vdc	rpm	Vdc	rpm	Vdc	rpm	Vdc	rpm	Vdc
2550	1015	4.5	1128	5.1	1233	5.5	1330	6.0	1421	6.4
2760	1084	4.8	1190	5.3	1289	5.8	1382	6.2	1470	6.6
2975	1154	5.2	1253	5.6	1348	6.1	1437	6.5	1521	6.9
3190	1225	5.5	1319	5.9	1408	6.3	1493	6.7	1574	7.1
3400	1297	5.8	1386	6.2	1470	6.6	1551	7.0	1629	7.4
3610	1370	6.2	1453	6.6	1534	6.9	1612	7.3	1687	7.6
3825	1443	6.5	1522	6.9	1599	7.2	1673	7.6	1745	7.9
4040	1517	6.8	1592	7.2	1665	7.5	1736	7.9	1806	8.2
4250	1591	7.2	1663	7.5	1733	7.8	1801	8.2	1867	8.5

CFM	AVAILABLE EXTERNAL STATIC PRESSURE (in. wg)									
	1.2		1.4		1.6		1.8		2.0	
	rpm	Vdc	rpm	Vdc	rpm	Vdc	rpm	Vdc	rpm	Vdc
2550	1506	6.8	1586	7.2	1662	7.5	1734	7.8	1802	8.2
2760	1552	7.0	1630	7.4	1705	7.7	1776	8.0	1843	8.4
2975	1601	7.2	1677	7.6	1750	7.9	1819	8.2	1886	8.6
3190	1652	7.5	1726	7.8	1796	8.1	1864	8.4	1930	8.8
3400	1704	7.7	1776	8.0	1845	8.4	1911	8.7	1975	9.0
3610	1759	8.0	1828	8.3	1895	8.6	1960	8.9	2023	9.2
3825	1815	8.2	1882	8.5	1947	8.8	2011	9.1	2072	9.4
4040	1873	8.5	1938	8.8	2001	9.1	2063	9.4	2122	9.6
4250	1932	8.8	1995	9.1	2056	9.3	2116	9.6	—	—

High Static 1015-2200 rpm

Fan data (cont)

RAV120 — 10 TON VERTICAL SUPPLY (RPM — BHP)

CFM	AVAILABLE EXTERNAL STATIC PRESSURE (in. wg)									
	0.2		0.4		0.6		0.8		1.0	
	rpm	bhp	rpm	bhp	rpm	bhp	rpm	bhp	rpm	bhp
3000	1181	0.60	1279	0.77	1372	0.95	1461	1.14	1544	1.35
3250	1264	0.73	1356	0.91	1443	1.09	1527	1.29	1607	1.51
3500	1348	0.88	1434	1.06	1517	1.25	1596	1.46	1673	1.68
3750	1433	1.04	1514	1.23	1592	1.43	1667	1.64	1740	1.86
4000	1518	1.21	1595	1.41	1669	1.61	1740	1.83	1810	2.06
4250	1605	1.41	1677	1.60	1747	1.81	1815	2.03	1882	2.27
4500	1691	1.60	1760	1.81	1826	2.02	1892	2.24	1955	2.48
4750	1778	1.81	1843	2.01	1907	2.23	1969	2.46	2030	2.69
5000	1866	2.02	1928	2.23	1988	2.44	2048	2.67	2106	2.91

CFM	AVAILABLE EXTERNAL STATIC PRESSURE (in. wg)									
	1.2		1.4		1.6		1.8		2.0	
	rpm	bhp	rpm	bhp	rpm	bhp	rpm	bhp	rpm	bhp
3000	1624	1.57	1699	1.80	1771	2.04	1840	2.29	1906	2.54
3250	1684	1.73	1757	1.97	1827	2.21	1894	2.47	1958	2.72
3500	1746	1.91	1817	2.15	1884	2.40	1950	2.66	2013	2.92
3750	1811	2.10	1879	2.34	1945	2.60	2008	2.86	2070	3.13
4000	1878	2.30	1943	2.55	2007	2.81	2069	3.08	2128	3.35
4250	1947	2.51	2010	2.76	2071	3.02	2131	3.29	2189	3.56
4500	2017	2.72	2078	2.97	2138	3.24	2195	3.50	—	—
4750	2090	2.94	2148	3.19	—	—	—	—	—	—
5000	2164	3.15	—	—	—	—	—	—	—	—

Std/Med Static 1181-2000 rpm, 2.4 Max bhp

High Static 1181-2200 rpm, 5.0 Max bhp

RAV120 — STANDARD/MEDIUM STATIC — 10 TON VERTICAL SUPPLY (RPM — VDC)

CFM	AVAILABLE EXTERNAL STATIC PRESSURE (in. wg)									
	0.2		0.4		0.6		0.8		1.0	
	rpm	Vdc	rpm	Vdc	rpm	Vdc	rpm	Vdc	rpm	Vdc
3000	1181	5.8	1279	6.3	1372	6.8	1461	7.2	1544	7.7
3250	1264	6.2	1356	6.7	1443	7.1	1527	7.6	1607	8.0
3500	1348	6.6	1434	7.1	1517	7.5	1596	7.9	1673	8.3
3750	1433	7.1	1514	7.5	1592	7.9	1667	8.3	1740	8.7
4000	1518	7.5	1595	7.9	1669	8.3	1740	8.7	1810	9.0
4250	1605	8.0	1677	8.3	1747	8.7	1815	9.0	1882	9.4
4500	1691	8.4	1760	8.8	1826	9.1	1892	9.4	—	—
4750	1778	8.9	1843	9.2	1907	9.5	—	—	—	—
5000	1866	9.3	1928	9.6	1988	9.9	—	—	—	—

CFM	AVAILABLE EXTERNAL STATIC PRESSURE (in. wg)									
	1.2		1.4		1.6		1.8		2.0	
	rpm	Vdc	rpm	Vdc	rpm	Vdc	rpm	Vdc	rpm	Vdc
3000	1624	8.1	1699	8.5	1771	8.8	1840	9.2	—	—
3250	1684	8.4	1757	8.8	1827	9.1	—	—	—	—
3500	1746	8.7	1817	9.1	1884	9.4	—	—	—	—
3750	1811	9.0	1879	9.4	—	—	—	—	—	—
4000	1878	9.4	—	—	—	—	—	—	—	—
4250	—	—	—	—	—	—	—	—	—	—
4500	—	—	—	—	—	—	—	—	—	—
4750	—	—	—	—	—	—	—	—	—	—
5000	—	—	—	—	—	—	—	—	—	—

Std/Med Static 1181-2000 rpm

Fan data (cont)

RAV120 — HIGH STATIC — 10 TON VERTICAL SUPPLY (RPM — VDC)

CFM	AVAILABLE EXTERNAL STATIC PRESSURE (in. wg)									
	0.2		0.4		0.6		0.8		1.0	
	rpm	Vdc	rpm	Vdc	rpm	Vdc	rpm	Vdc	rpm	Vdc
3000	1181	5.3	1279	5.7	1372	6.2	1461	6.6	1544	7.0
3250	1264	5.7	1356	6.1	1443	6.5	1527	6.9	1607	7.3
3500	1348	6.1	1434	6.5	1517	6.8	1596	7.2	1673	7.6
3750	1433	6.5	1514	6.8	1592	7.2	1667	7.5	1740	7.9
4000	1518	6.9	1595	7.2	1669	7.5	1740	7.9	1810	8.2
4250	1605	7.3	1677	7.6	1747	7.9	1815	8.2	1882	8.5
4500	1691	7.7	1760	8.0	1826	8.3	1892	8.6	1955	8.9
4750	1778	8.1	1843	8.4	1907	8.6	1969	8.9	2030	9.2
5000	1866	8.5	1928	8.7	1988	9.0	2048	9.3	2106	9.6

CFM	AVAILABLE EXTERNAL STATIC PRESSURE (in. wg)									
	1.2		1.4		1.6		1.8		2.0	
	rpm	Vdc	rpm	Vdc	rpm	Vdc	rpm	Vdc	rpm	Vdc
3000	1624	7.3	1699	7.7	1771	8.0	1840	8.3	1906	8.6
3250	1684	7.6	1757	8.0	1827	8.3	1894	8.6	1958	8.9
3500	1746	7.9	1817	8.2	1884	8.5	1950	8.8	2013	9.1
3750	1811	8.2	1879	8.5	1945	8.8	2008	9.1	2070	9.4
4000	1878	8.5	1943	8.8	2007	9.1	2069	9.4	2128	9.7
4250	1947	8.8	2010	9.1	2071	9.4	2131	9.7	2189	9.9
4500	2017	9.2	2078	9.4	2138	9.7	2195	10.0	—	—
4750	2090	9.5	2148	9.8	—	—	—	—	—	—
5000	2164	9.8	—	—	—	—	—	—	—	—

High Static 1181-2200 rpm

Fan data (cont)

RAV150 — 12.5 TON VERTICAL SUPPLY (RPM — BHP)

CFM	AVAILABLE EXTERNAL STATIC PRESSURE (in. wg)									
	0.2		0.4		0.6		0.8		1.0	
	rpm	bhp	rpm	bhp	rpm	bhp	rpm	bhp	rpm	bhp
3750	1178	0.86	1287	1.12	1386	1.40	1475	1.69	1558	1.99
4060	1260	1.05	1362	1.32	1456	1.62	1543	1.92	1623	2.24
4375	1343	1.26	1438	1.55	1528	1.86	1612	2.19	1690	2.52
4690	1426	1.51	1516	1.81	1602	2.14	1683	2.48	1759	2.83
5000	1511	1.78	1595	2.09	1677	2.43	1755	2.79	1828	3.15
5310	1596	2.08	1675	2.41	1753	2.76	1828	3.13	1899	3.51
5625	1681	2.41	1756	2.74	1830	3.10	1902	3.49	1971	3.88
5940	1767	2.76	1838	3.10	1909	3.48	1978	3.87	2045	4.28
6250	1854	3.14	1921	3.49	1989	3.88	2055	4.27	2119	4.69

CFM	AVAILABLE EXTERNAL STATIC PRESSURE (in. wg)									
	1.2		1.4		1.6		1.8		2.0	
	rpm	bhp	rpm	bhp	rpm	bhp	rpm	bhp	rpm	bhp
3750	1634	2.29	1705	2.61	1772	2.93	1837	3.26	1898	3.60
4060	1698	2.57	1768	2.90	1834	3.23	1897	3.58	1957	3.93
4375	1763	2.86	1832	3.21	1897	3.56	1959	3.92	2018	4.29
4690	1830	3.18	1897	3.55	1961	3.92	2022	4.29	2081	4.68
5000	1898	3.53	1964	3.91	2027	4.30	2087	4.69	2144	5.09
5310	1967	3.90	2031	4.29	2093	4.69	2152	5.10	—	—
5625	2037	4.28	2100	4.69	2161	5.11	—	—	—	—
5940	2109	4.69	2170	5.11	—	—	—	—	—	—
6250	2181	5.11	—	—	—	—	—	—	—	—

Std/Med Static 1178-2200 rpm, 3.0 Max bhp

High Static 1178-2200 rpm, 5.0 Max bhp

RAV150 — STANDARD/MEDIUM STATIC — 12.5 TON VERTICAL SUPPLY (RPM — VDC)

CFM	AVAILABLE EXTERNAL STATIC PRESSURE (in. wg)									
	0.2		0.4		0.6		0.8		1.0	
	rpm	Vdc	rpm	Vdc	rpm	Vdc	rpm	Vdc	rpm	Vdc
3750	1178	5.3	1287	5.8	1386	6.2	1475	6.7	1558	7.0
4060	1260	5.7	1362	6.1	1456	6.6	1543	7.0	1623	7.3
4375	1343	6.0	1438	6.5	1528	6.9	1612	7.3	1690	7.6
4690	1426	6.4	1516	6.8	1602	7.2	1683	7.6	1759	8.0
5000	1511	6.8	1595	7.2	1677	7.6	1755	7.9	—	—
5310	1596	7.2	1675	7.6	1753	7.9	—	—	—	—
5625	1681	7.6	1756	8.0	—	—	—	—	—	—
5940	1767	8.0	—	—	—	—	—	—	—	—
6250	—	—	—	—	—	—	—	—	—	—

CFM	AVAILABLE EXTERNAL STATIC PRESSURE (in. wg)									
	1.2		1.4		1.6		1.8		2.0	
	rpm	Vdc	rpm	Vdc	rpm	Vdc	rpm	Vdc	rpm	Vdc
3750	1634	7.4	1705	7.7	1772	8.0	—	—	—	—
4060	1698	7.7	1768	8.0	—	—	—	—	—	—
4375	1763	8.0	—	—	—	—	—	—	—	—
4690	—	—	—	—	—	—	—	—	—	—
5000	—	—	—	—	—	—	—	—	—	—
5310	—	—	—	—	—	—	—	—	—	—
5625	—	—	—	—	—	—	—	—	—	—
5940	—	—	—	—	—	—	—	—	—	—
6250	—	—	—	—	—	—	—	—	—	—

Std/Med Static 1178-2200 rpm

Fan data (cont)

RAV150 — HIGH STATIC — 12.5 TON VERTICAL SUPPLY (RPM — VDC)

CFM	AVAILABLE EXTERNAL STATIC PRESSURE (in. wg)									
	0.2		0.4		0.6		0.8		1.0	
	rpm	Vdc	rpm	Vdc	rpm	Vdc	rpm	Vdc	rpm	Vdc
3750	1178	5.3	1287	5.8	1386	6.2	1475	6.7	1558	7.0
4060	1260	5.7	1362	6.1	1456	6.6	1543	7.0	1623	7.3
4375	1343	6.0	1438	6.5	1528	6.9	1612	7.3	1690	7.6
4690	1426	6.4	1516	6.8	1602	7.2	1683	7.6	1759	8.0
5000	1511	6.8	1595	7.2	1677	7.6	1755	7.9	1828	8.3
5310	1596	7.2	1675	7.6	1753	7.9	1828	8.3	1899	8.6
5625	1681	7.6	1756	8.0	1830	8.3	1902	8.6	1971	8.9
5940	1767	8.0	1838	8.3	1909	8.7	1978	9.0	2045	9.3
6250	1854	8.4	1921	8.7	1989	9.0	2055	9.3	2119	9.6

CFM	AVAILABLE EXTERNAL STATIC PRESSURE (in. wg)									
	1.2		1.4		1.6		1.8		2.0	
	rpm	Vdc	rpm	Vdc	rpm	Vdc	rpm	Vdc	rpm	Vdc
3750	1634	7.4	1705	7.7	1772	8.0	1837	8.3	1898	8.6
4060	1698	7.7	1768	8.0	1834	8.3	1897	8.6	1957	8.9
4375	1763	8.0	1832	8.3	1897	8.6	1959	8.9	2018	9.2
4690	1830	8.3	1897	8.6	1961	8.9	2022	9.2	2081	9.5
5000	1898	8.6	1964	8.9	2027	9.2	2087	9.5	2144	9.7
5310	1967	8.9	2031	9.2	2093	9.5	2152	9.8	—	—
5625	2037	9.2	2100	9.5	2161	9.8	—	—	—	—
5940	2109	9.6	2170	9.9	—	—	—	—	—	—
6250	2181	9.9	—	—	—	—	—	—	—	—

High Static 1178-2200 rpm

Fan data (cont)

RAV180 — 15 TON VERTICAL SUPPLY (RPM — BHP)

CFM	AVAILABLE EXTERNAL STATIC PRESSURE (in. wg)									
	0.2		0.4		0.6		0.8		1.0	
	rpm	bhp	rpm	bhp	rpm	bhp	rpm	bhp	rpm	bhp
4500	1120	0.73	1201	0.90	1281	1.10	1361	1.32	1441	1.56
4875	1208	0.92	1283	1.10	1357	1.30	1431	1.52	1505	1.77
5250	1297	1.12	1367	1.32	1436	1.52	1504	1.75	1573	2.00
5625	1387	1.36	1452	1.56	1516	1.77	1581	2.01	1645	2.26
6000	1477	1.61	1538	1.82	1598	2.04	1659	2.28	1719	2.54
6375	1568	1.89	1625	2.10	1682	2.33	1739	2.58	1796	2.84
6750	1659	2.20	1713	2.42	1767	2.66	1821	2.91	1874	3.17
7125	1751	2.56	1802	2.79	1891	3.23	1904	3.29	1955	3.56
7500	1842	2.99	1891	3.23	1891	3.23	1988	3.75	2036	4.03

CFM	AVAILABLE EXTERNAL STATIC PRESSURE (in. wg)									
	1.2		1.4		1.6		1.8		2.0	
	rpm	bhp	rpm	bhp	rpm	bhp	rpm	bhp	rpm	bhp
4500	1520	1.83	1597	2.13	1673	2.45	1747	2.79	1818	3.14
4875	1579	2.05	1651	2.34	1723	2.66	1793	2.99	1861	3.35
5250	1642	2.28	1710	2.57	1777	2.89	1844	3.23	1909	3.58
5625	1709	2.54	1773	2.83	1836	3.14	1899	3.48	1961	3.83
6000	1779	2.81	1840	3.11	1899	3.42	1959	3.76	2018	4.11
6375	1853	3.12	1909	3.41	1966	3.73	2022	4.05	2078	4.40
6750	1928	3.45	1982	3.75	2035	4.06	2089	4.39	2142	4.73
7125	2006	3.84	2056	4.14	2107	4.46	2158	4.79	—	—
7500	2085	4.33	2133	4.64	2181	4.96	—	—	—	—

Std/Med Static 1120-2200 rpm, 3.0 Max bhp

High Static 1120-2200 rpm, 5.0 Max bhp

RAV180 — STANDARD/MEDIUM STATIC — 15 TON VERTICAL SUPPLY (RPM — VDC)

CFM	AVAILABLE EXTERNAL STATIC PRESSURE (in. wg)									
	0.2		0.4		0.6		0.8		1.0	
	rpm	Vdc	rpm	Vdc	rpm	Vdc	rpm	Vdc	rpm	Vdc
4500	1120	5.0	1201	5.4	1281	5.8	1361	6.1	1441	6.5
4875	1208	5.4	1283	5.8	1357	6.1	1431	6.5	1505	6.8
5250	1297	5.8	1367	6.2	1436	6.5	1504	6.8	1573	7.1
5625	1387	6.2	1452	6.5	1516	6.8	1581	7.1	1645	7.4
6000	1477	6.7	1538	6.9	1598	7.2	1659	7.5	1719	7.8
6375	1568	7.1	1625	7.3	1682	7.6	1739	7.9	1796	8.1
6750	1659	7.5	1713	7.8	1767	8.0	1821	8.3	—	—
7125	1751	7.9	1802	8.2	—	—	—	—	—	—
7500	1842	8.3	—	—	—	—	—	—	—	—

CFM	AVAILABLE EXTERNAL STATIC PRESSURE (in. wg)									
	1.2		1.4		1.6		1.8		2.0	
	rpm	Vdc	rpm	Vdc	rpm	Vdc	rpm	Vdc	rpm	Vdc
4500	1520	6.9	1597	7.2	1673	7.6	1747	7.9	—	—
4875	1579	7.1	1651	7.5	1723	7.8	1793	8.1	—	—
5250	1642	7.4	1710	7.7	1777	8.0	—	—	—	—
5625	1709	7.7	1773	8.0	1836	8.3	—	—	—	—
6000	1779	8.1	1840	8.3	—	—	—	—	—	—
6375	—	—	—	—	—	—	—	—	—	—
6750	—	—	—	—	—	—	—	—	—	—
7125	—	—	—	—	—	—	—	—	—	—
7500	—	—	—	—	—	—	—	—	—	—

Std/Med Static 1120-2200 rpm

Fan data (cont)

RAV180 — HIGH STATIC — 15 TON VERTICAL SUPPLY (RPM — VDC)

CFM	AVAILABLE EXTERNAL STATIC PRESSURE (in. wg)									
	0.2		0.4		0.6		0.8		1.0	
	rpm	Vdc	rpm	Vdc	rpm	Vdc	rpm	Vdc	rpm	Vdc
4500	1120	5.0	1201	5.4	1281	5.8	1361	6.1	1441	6.5
4875	1208	5.4	1283	5.8	1357	6.1	1431	6.5	1505	6.8
5250	1297	5.8	1367	6.2	1436	6.5	1504	6.8	1573	7.1
5625	1387	6.2	1452	6.5	1516	6.8	1581	7.1	1645	7.4
6000	1477	6.7	1538	6.9	1598	7.2	1659	7.5	1719	7.8
6375	1568	7.1	1625	7.3	1682	7.6	1739	7.9	1796	8.1
6750	1659	7.5	1713	7.8	1767	8.0	1821	8.3	1874	8.5
7125	1751	7.9	1802	8.2	1853	8.4	1904	8.6	1955	8.9
7500	1842	8.3	1891	8.6	1940	8.8	1988	9.0	2036	9.2

CFM	AVAILABLE EXTERNAL STATIC PRESSURE (in. wg)									
	1.2		1.4		1.6		1.8		2.0	
	rpm	Vdc	rpm	Vdc	rpm	Vdc	rpm	Vdc	rpm	Vdc
4500	1520	6.9	1597	7.2	1673	7.6	1747	7.9	1818	8.2
4875	1579	7.1	1651	7.5	1723	7.8	1793	8.1	1861	8.4
5250	1642	7.4	1710	7.7	1777	8.0	1844	8.4	1909	8.7
5625	1709	7.7	1773	8.0	1836	8.3	1899	8.6	1961	8.9
6000	1779	8.1	1840	8.3	1899	8.6	1959	8.9	2018	9.2
6375	1853	8.4	1909	8.7	1966	8.9	2022	9.2	2078	9.4
6750	1928	8.7	1982	9.0	2035	9.2	2089	9.5	2142	9.7
7125	2006	9.1	2056	9.3	2107	9.6	2158	9.8	—	—
7500	2085	9.5	2133	9.7	2181	9.9	—	—	—	—

High Static 1120-2200 rpm

Fan data (cont)

RAV090 — 7.5 TON HORIZONTAL SUPPLY (RPM — BHP)

CFM	AVAILABLE EXTERNAL STATIC PRESSURE (in. wg)									
	0.2		0.4		0.6		0.8		1.0	
	rpm	bhp	rpm	bhp	rpm	bhp	rpm	bhp	rpm	bhp
2250	910	0.28	1046	0.43	1167	0.60	1276	0.78	1376	0.98
2440	966	0.34	1095	0.49	1211	0.67	1316	0.86	1414	1.06
2625	1023	0.40	1145	0.56	1256	0.74	1359	0.94	1453	1.15
2810	1081	0.47	1197	0.64	1304	0.82	1403	1.02	1495	1.24
3000	1141	0.54	1251	0.72	1353	0.91	1449	1.12	1538	1.33
3190	1200	0.63	1306	0.81	1404	1.00	1496	1.21	1583	1.44
3375	1261	0.71	1361	0.90	1456	1.10	1545	1.31	1629	1.54
3560	1322	0.81	1418	1.00	1509	1.20	1595	1.42	1677	1.65
3750	1384	0.91	1476	1.10	1563	1.30	1646	1.52	1725	1.75

CFM	AVAILABLE EXTERNAL STATIC PRESSURE (in. wg)									
	1.2		1.4		1.6		1.8		2.0	
	rpm	bhp	rpm	bhp	rpm	bhp	rpm	bhp	rpm	bhp
2250	1469	1.19	1556	1.42	1639	1.66	1716	1.90	1790	2.16
2440	1505	1.28	1590	1.51	1671	1.75	1748	2.01	1821	2.27
2625	1542	1.37	1626	1.61	1705	1.85	1781	2.11	1853	2.38
2810	1581	1.46	1663	1.70	1741	1.96	1816	2.22	1887	2.49
3000	1622	1.57	1702	1.81	1778	2.06	1852	2.33	1922	2.60
3190	1665	1.67	1743	1.92	1818	2.18	1889	2.44	1958	2.72
3375	1709	1.78	1785	2.03	1858	2.29	1928	2.55	1996	2.83
3560	1755	1.89	1829	2.14	1900	2.40	1969	2.67	2035	2.95
3750	1801	2.00	1874	2.25	1944	2.51	2011	2.78	2076	3.06

Std/Med Static 910-2000 rpm, 2.4 Max bhp

High Static 910-2200 rpm, 3.0 Max bhp

RAV090 — STANDARD/MEDIUM STATIC — 7.5 TON HORIZONTAL SUPPLY (RPM — VDC)

CFM	AVAILABLE EXTERNAL STATIC PRESSURE (in. wg)									
	0.2		0.4		0.6		0.8		1.0	
	rpm	Vdc	rpm	Vdc	rpm	Vdc	rpm	Vdc	rpm	Vdc
2250	910	4.4	1046	5.1	1167	5.7	1276	6.3	1376	6.8
2440	966	4.7	1095	5.3	1211	5.9	1316	6.5	1414	7.0
2625	1023	5.0	1145	5.6	1256	6.2	1359	6.7	1453	7.2
2810	1081	5.3	1197	5.9	1304	6.4	1403	6.9	1495	7.4
3000	1141	5.6	1251	6.1	1353	6.7	1449	7.2	1538	7.6
3190	1200	5.9	1306	6.4	1404	6.9	1496	7.4	1583	7.9
3375	1261	6.2	1361	6.7	1456	7.2	1545	7.7	1629	8.1
3560	1322	6.5	1418	7.0	1509	7.5	1595	7.9	1677	8.3
3750	1384	6.8	1476	7.3	1563	7.8	1646	8.2	1725	8.6

CFM	AVAILABLE EXTERNAL STATIC PRESSURE (in. wg)									
	1.2		1.4		1.6		1.8		2.0	
	rpm	Vdc	rpm	Vdc	rpm	Vdc	rpm	Vdc	rpm	Vdc
2250	1469	7.3	1556	7.7	1639	8.1	1716	8.5	1790	8.9
2440	1505	7.5	1590	7.9	1671	8.3	1748	8.7	1821	9.1
2625	1542	7.6	1626	8.1	1705	8.5	1781	8.9	1853	9.2
2810	1581	7.8	1663	8.3	1741	8.7	1816	9.1	—	—
3000	1622	8.1	1702	8.5	1778	8.9	1852	9.2	—	—
3190	1665	8.3	1743	8.7	1818	9.1	—	—	—	—
3375	1709	8.5	1785	8.9	1858	9.3	—	—	—	—
3560	1755	8.7	1829	9.1	—	—	—	—	—	—
3750	1801	9.0	1874	9.4	—	—	—	—	—	—

Std/Med Static 910-2000 rpm

Fan data (cont)

RAV090 — HIGH STATIC — 7.5 TON HORIZONTAL SUPPLY (RPM — VDC)

CFM	AVAILABLE EXTERNAL STATIC PRESSURE (in. wg)									
	0.2		0.4		0.6		0.8		1.0	
	rpm	Vdc	rpm	Vdc	rpm	Vdc	rpm	Vdc	rpm	Vdc
2250	910	4.0	1046	4.7	1167	5.2	1276	5.7	1376	6.2
2440	966	4.3	1095	4.9	1211	5.4	1316	5.9	1414	6.4
2625	1023	4.6	1145	5.1	1256	5.6	1359	6.1	1453	6.6
2810	1081	4.8	1197	5.4	1304	5.9	1403	6.3	1495	6.7
3000	1141	5.1	1251	5.6	1353	6.1	1449	6.5	1538	6.9
3190	1200	5.4	1306	5.9	1404	6.3	1496	6.8	1583	7.2
3375	1261	5.7	1361	6.1	1456	6.6	1545	7.0	1629	7.4
3560	1322	5.9	1418	6.4	1509	6.8	1595	7.2	1677	7.6
3750	1384	6.2	1476	6.7	1563	7.1	1646	7.4	1725	7.8

CFM	AVAILABLE EXTERNAL STATIC PRESSURE (in. wg)									
	1.2		1.4		1.6		1.8		2.0	
	rpm	Vdc	rpm	Vdc	rpm	Vdc	rpm	Vdc	rpm	Vdc
2250	1469	6.6	1556	7.0	1639	7.4	1716	7.8	1790	8.1
2440	1505	6.8	1590	7.2	1671	7.6	1748	7.9	1821	8.3
2625	1542	7.0	1626	7.4	1705	7.7	1781	8.1	1853	8.4
2810	1581	7.1	1663	7.5	1741	7.9	1816	8.2	1887	8.6
3000	1622	7.3	1702	7.7	1778	8.1	1852	8.4	1922	8.7
3190	1665	7.5	1743	7.9	1818	8.2	1889	8.6	1958	8.9
3375	1709	7.7	1785	8.1	1858	8.4	1928	8.7	1996	9.1
3560	1755	7.9	1829	8.3	1900	8.6	1969	8.9	2035	9.2
3750	1801	8.2	1874	8.5	1944	8.8	2011	9.1	2076	9.4

High Static 910-2200 rpm

Fan data (cont)

RAV102 — 8.5 TON HORIZONTAL SUPPLY (RPM — BHP)

CFM	AVAILABLE EXTERNAL STATIC PRESSURE (in. wg)									
	0.2		0.4		0.6		0.8		1.0	
	rpm	bhp	rpm	bhp	rpm	bhp	rpm	bhp	rpm	bhp
2550	947	0.31	1065	0.45	1178	0.60	1284	0.78	1382	0.97
2760	1010	0.38	1120	0.51	1226	0.67	1327	0.85	1422	1.05
2975	1074	0.45	1177	0.59	1277	0.75	1373	0.94	1464	1.13
3190	1139	0.53	1235	0.67	1329	0.84	1421	1.02	1508	1.22
3400	1205	0.62	1296	0.77	1384	0.93	1471	1.12	1555	1.32
3610	1272	0.71	1357	0.86	1441	1.03	1524	1.22	1604	1.43
3825	1340	0.81	1420	0.97	1499	1.14	1578	1.33	1655	1.53
4040	1407	0.92	1484	1.08	1559	1.25	1634	1.44	1707	1.64
4250	1476	1.03	1548	1.19	1620	1.36	1691	1.55	1762	1.75

CFM	AVAILABLE EXTERNAL STATIC PRESSURE (in. wg)									
	1.2		1.4		1.6		1.8		2.0	
	rpm	bhp	rpm	bhp	rpm	bhp	rpm	bhp	rpm	bhp
2550	1473	1.18	1558	1.39	1638	1.62	1713	1.85	1785	2.10
2760	1511	1.26	1595	1.48	1674	1.71	1748	1.95	1819	2.20
2975	1551	1.35	1633	1.57	1710	1.81	1784	2.05	1855	2.31
3190	1592	1.44	1672	1.67	1749	1.91	1822	2.16	1891	2.41
3400	1636	1.54	1714	1.77	1789	2.01	1860	2.26	1929	2.52
3610	1682	1.64	1757	1.87	1830	2.12	1900	2.37	1968	2.63
3825	1730	1.75	1803	1.98	1873	2.22	1942	2.48	2008	2.74
4040	1779	1.86	1850	2.09	1918	2.33	1985	2.58	2050	2.84
4250	1831	1.97	1899	2.19	1965	2.43	2030	2.68	2093	2.94

Std/Med Static 947-2000 rpm, 2.4 Max bhp

High Static 947-2200 rpm, 3.0 Max bhp

RAV102 — STANDARD/MEDIUM STATIC — 8.5 TON HORIZONTAL SUPPLY (RPM — VDC)

CFM	AVAILABLE EXTERNAL STATIC PRESSURE (in. wg)									
	0.2		0.4		0.6		0.8		1.0	
	rpm	Vdc	rpm	Vdc	rpm	Vdc	rpm	Vdc	rpm	Vdc
2550	947	4.6	1065	5.2	1178	5.8	1284	6.3	1382	6.8
2760	1010	4.9	1120	5.5	1226	6.0	1327	6.5	1422	7.0
2975	1074	5.2	1177	5.8	1277	6.3	1373	6.8	1464	7.2
3190	1139	5.6	1235	6.1	1329	6.5	1421	7.0	1508	7.5
3400	1205	5.9	1296	6.4	1384	6.8	1471	7.3	1555	7.7
3610	1272	6.3	1357	6.7	1441	7.1	1524	7.6	1604	8.0
3825	1340	6.6	1420	7.0	1499	7.4	1578	7.8	1655	8.2
4040	1407	7.0	1484	7.3	1559	7.7	1634	8.1	1707	8.5
4250	1476	7.3	1548	7.7	1620	8.0	1691	8.4	1762	8.8

CFM	AVAILABLE EXTERNAL STATIC PRESSURE (in. wg)									
	1.2		1.4		1.6		1.8		2.0	
	rpm	Vdc	rpm	Vdc	rpm	Vdc	rpm	Vdc	rpm	Vdc
2550	1473	7.3	1558	7.7	1638	8.1	1713	8.5	1785	8.9
2760	1511	7.5	1595	7.9	1674	8.3	1748	8.7	1819	9.1
2975	1551	7.7	1633	8.1	1710	8.5	1784	8.9	1855	9.3
3190	1592	7.9	1672	8.3	1749	8.7	1822	9.1	—	—
3400	1636	8.1	1714	8.5	1789	8.9	1860	9.3	—	—
3610	1682	8.4	1757	8.8	1830	9.1	1900	9.5	—	—
3825	1730	8.6	1803	9.0	1873	9.3	—	—	—	—
4040	1779	8.9	1850	9.2	1918	9.6	—	—	—	—
4250	1831	9.1	1899	9.5	—	—	—	—	—	—

Std/Med Static 947-2000 rpm

Fan data (cont)

RAV102 — HIGH STATIC — 8.5 TON HORIZONTAL SUPPLY (RPM — VDC)

CFM	AVAILABLE EXTERNAL STATIC PRESSURE (in. wg)									
	0.2		0.4		0.6		0.8		1.0	
	rpm	Vdc	rpm	Vdc	rpm	Vdc	rpm	Vdc	rpm	Vdc
2550	947	4.2	1065	4.8	1178	5.3	1284	5.8	1382	6.2
2760	1010	4.5	1120	5.0	1226	5.5	1327	6.0	1422	6.4
2975	1074	4.8	1177	5.3	1277	5.7	1373	6.2	1464	6.6
3190	1139	5.1	1235	5.5	1329	6.0	1421	6.4	1508	6.8
3400	1205	5.4	1296	5.8	1384	6.2	1471	6.6	1555	7.0
3610	1272	5.7	1357	6.1	1441	6.5	1524	6.9	1604	7.2
3825	1340	6.0	1420	6.4	1499	6.8	1578	7.1	1655	7.5
4040	1407	6.3	1484	6.7	1559	7.0	1634	7.4	1707	7.7
4250	1476	6.7	1548	7.0	1620	7.3	1691	7.7	1762	8.0

CFM	AVAILABLE EXTERNAL STATIC PRESSURE (in. wg)									
	1.2		1.4		1.6		1.8		2.0	
	rpm	Vdc	rpm	Vdc	rpm	Vdc	rpm	Vdc	rpm	Vdc
2550	1473	6.6	1558	7.0	1638	7.4	1713	7.8	1785	8.1
2760	1511	6.8	1595	7.2	1674	7.6	1748	7.9	1819	8.2
2975	1551	7.0	1633	7.4	1710	7.7	1784	8.1	1855	8.4
3190	1592	7.2	1672	7.6	1749	7.9	1822	8.3	1891	8.6
3400	1636	7.4	1714	7.8	1789	8.1	1860	8.4	1929	8.7
3610	1682	7.6	1757	8.0	1830	8.3	1900	8.6	1968	8.9
3825	1730	7.8	1803	8.2	1873	8.5	1942	8.8	2008	9.1
4040	1779	8.1	1850	8.4	1918	8.7	1985	9.0	2050	9.3
4250	1831	8.3	1899	8.6	1965	8.9	2030	9.2	2093	9.5

High Static 947-2200 rpm

Fan data (cont)

RAV120 — 10 TON HORIZONTAL SUPPLY (RPM — BHP)

CFM	AVAILABLE EXTERNAL STATIC PRESSURE (in. wg)									
	0.2		0.4		0.6		0.8		1.0	
	rpm	bhp	rpm	bhp	rpm	bhp	rpm	bhp	rpm	bhp
3000	1100	0.49	1202	0.64	1301	0.81	1396	1.00	1487	1.21
3250	1176	0.59	1270	0.74	1363	0.92	1453	1.11	1539	1.32
3500	1252	0.70	1341	0.86	1428	1.04	1512	1.24	1595	1.45
3750	1330	0.83	1413	1.00	1495	1.18	1575	1.38	1653	1.60
4000	1409	0.97	1487	1.14	1563	1.33	1639	1.53	1714	1.75
4250	1488	1.12	1561	1.29	1634	1.48	1706	1.69	1776	1.90
4500	1568	1.28	1637	1.45	1706	1.65	1774	1.85	1841	2.07
4750	1648	1.44	1714	1.62	1779	1.81	1844	2.02	1908	2.23
5000	1728	1.61	1791	1.79	1853	1.98	1915	2.19	1976	2.40

CFM	AVAILABLE EXTERNAL STATIC PRESSURE (in. wg)									
	1.2		1.4		1.6		1.8		2.0	
	rpm	bhp	rpm	bhp	rpm	bhp	rpm	bhp	rpm	bhp
3000	1573	1.43	1654	1.66	1732	1.91	1805	2.16	1875	2.42
3250	1622	1.55	1702	1.79	1777	2.04	1849	2.29	1919	2.57
3500	1674	1.68	1751	1.92	1825	2.18	1895	2.44	1964	2.72
3750	1729	1.83	1803	2.07	1874	2.33	1943	2.59	2010	2.87
4000	1786	1.98	1857	2.22	1926	2.48	1993	2.75	2058	3.03
4250	1846	2.14	1914	2.38	1980	2.64	2045	2.91	2108	3.18
4500	1908	2.30	1973	2.54	2036	2.80	2099	3.06	2160	3.34
4750	1971	2.46	2034	2.71	2095	2.96	2155	3.22	—	—
5000	2036	2.63	2096	2.87	2155	3.11	—	—	—	—

Std/Med Static 1100-2000 rpm, 2.4 Max bhp

High Static 1100-2200 rpm, 5.0 Max bhp

RAV120 — STANDARD/MEDIUM STATIC — 10 TON HORIZONTAL SUPPLY (RPM — VDC)

CFM	AVAILABLE EXTERNAL STATIC PRESSURE (in. wg)									
	0.2		0.4		0.6		0.8		1.0	
	rpm	Vdc	rpm	Vdc	rpm	Vdc	rpm	Vdc	rpm	Vdc
3000	1100	5.4	1202	5.9	1301	6.4	1396	6.9	1487	7.4
3250	1176	5.8	1270	6.2	1363	6.7	1453	7.2	1539	7.6
3500	1252	6.2	1341	6.6	1428	7.1	1512	7.5	1595	7.9
3750	1330	6.6	1413	7.0	1495	7.4	1575	7.8	1653	8.2
4000	1409	7.0	1487	7.4	1563	7.8	1639	8.1	1714	8.5
4250	1488	7.4	1561	7.7	1634	8.1	1706	8.5	1776	8.8
4500	1568	7.8	1637	8.1	1706	8.5	1774	8.8	1841	9.2
4750	1648	8.2	1714	8.5	1779	8.9	1844	9.2	1908	9.5
5000	1728	8.6	1791	8.9	1853	9.2	1915	9.6	1976	9.9

CFM	AVAILABLE EXTERNAL STATIC PRESSURE (in. wg)									
	1.2		1.4		1.6		1.8		2.0	
	rpm	Vdc	rpm	Vdc	rpm	Vdc	rpm	Vdc	rpm	Vdc
3000	1573	7.8	1654	8.2	1732	8.6	1805	9.0	1875	9.4
3250	1622	8.1	1702	8.5	1777	8.9	1849	9.2	—	—
3500	1674	8.3	1751	8.7	1825	9.1	—	—	—	—
3750	1729	8.6	1803	9.0	1874	9.4	—	—	—	—
4000	1786	8.9	1857	9.3	—	—	—	—	—	—
4250	1846	9.2	1914	9.6	—	—	—	—	—	—
4500	1908	9.5	—	—	—	—	—	—	—	—
4750	—	—	—	—	—	—	—	—	—	—
5000	—	—	—	—	—	—	—	—	—	—

Std/Med Static 1100-2000 rpm

Fan data (cont)

RAV120 — HIGH STATIC — 10 TON HORIZONTAL SUPPLY (RPM — VDC)

CFM	AVAILABLE EXTERNAL STATIC PRESSURE (in. wg)									
	0.2		0.4		0.6		0.8		1.0	
	rpm	Vdc	rpm	Vdc	rpm	Vdc	rpm	Vdc	rpm	Vdc
3000	1100	4.9	1202	5.4	1301	5.9	1396	6.3	1487	6.7
3250	1176	5.3	1270	5.7	1363	6.1	1453	6.6	1539	6.9
3500	1252	5.6	1341	6.0	1428	6.4	1512	6.8	1595	7.2
3750	1330	6.0	1413	6.4	1495	6.7	1575	7.1	1653	7.5
4000	1409	6.3	1487	6.7	1563	7.1	1639	7.4	1714	7.8
4250	1488	6.7	1561	7.1	1634	7.4	1706	7.7	1776	8.0
4500	1568	7.1	1637	7.4	1706	7.7	1774	8.0	1841	8.3
4750	1648	7.5	1714	7.8	1779	8.1	1844	8.4	1908	8.7
5000	1728	7.8	1791	8.1	1853	8.4	1915	8.7	1976	9.0

CFM	AVAILABLE EXTERNAL STATIC PRESSURE (in. wg)									
	1.2		1.4		1.6		1.8		2.0	
	rpm	Vdc	rpm	Vdc	rpm	Vdc	rpm	Vdc	rpm	Vdc
3000	1573	7.1	1654	7.5	1732	7.8	1805	8.2	1875	8.5
3250	1622	7.3	1702	7.7	1777	8.0	1849	8.4	1919	8.7
3500	1674	7.6	1751	7.9	1825	8.3	1895	8.6	1964	8.9
3750	1729	7.8	1803	8.2	1874	8.5	1943	8.8	2010	9.1
4000	1786	8.1	1857	8.4	1926	8.7	1993	9.0	2058	9.3
4250	1846	8.4	1914	8.7	1980	9.0	2045	9.3	2108	9.6
4500	1908	8.7	1973	9.0	2036	9.2	2099	9.5	2160	9.8
4750	1971	8.9	2034	9.2	2095	9.5	2155	9.8	—	—
5000	2036	9.2	2096	9.5	2155	9.8	—	—	—	—

High Static 1100-2200 rpm

Fan data (cont)

RAV150 — 12.5 TON HORIZONTAL SUPPLY (RPM — BHP)

CFM	AVAILABLE EXTERNAL STATIC PRESSURE (in. wg)									
	0.2		0.4		0.6		0.8		1.0	
	rpm	bhp	rpm	bhp	rpm	bhp	rpm	bhp	rpm	bhp
3750	1072	0.65	1166	0.83	1266	1.07	1363	1.33	1454	1.62
4060	1148	0.79	1233	0.98	1324	1.22	1416	1.49	1504	1.78
4375	1226	0.96	1303	1.15	1386	1.39	1472	1.66	1556	1.97
4690	1304	1.15	1374	1.35	1451	1.59	1530	1.86	1610	2.17
5000	1383	1.37	1448	1.57	1518	1.81	1592	2.08	1667	2.39
5310	1463	1.60	1523	1.81	1588	2.05	1656	2.33	1726	2.63
5625	1543	1.86	1599	2.07	1659	2.31	1723	2.59	1789	2.90
5940	1623	2.14	1675	2.35	1732	2.60	1791	2.87	1853	3.18
6250	1704	2.44	1753	2.65	1806	2.90	1861	3.17	1919	3.48

CFM	AVAILABLE EXTERNAL STATIC PRESSURE (in. wg)									
	1.2		1.4		1.6		1.8		2.0	
	rpm	bhp	rpm	bhp	rpm	bhp	rpm	bhp	rpm	bhp
3750	1540	1.92	1620	2.24	1694	2.56	1765	2.89	1833	3.24
4060	1587	2.09	1666	2.42	1740	2.76	1810	3.11	1877	3.46
4375	1637	2.29	1713	2.62	1786	2.97	1856	3.34	1922	3.71
4690	1688	2.50	1763	2.85	1834	3.20	1902	3.57	1968	3.96
5000	1741	2.72	1813	3.08	1883	3.45	1950	3.83	2015	4.22
5310	1797	2.97	1867	3.33	1934	3.70	2000	4.10	2063	4.50
5625	1855	3.23	1922	3.60	1987	3.97	2050	4.36	2112	4.77
5940	1915	3.51	1979	3.88	2042	4.26	2103	4.65	2163	5.06
6250	1978	3.81	2038	4.17	2098	4.55	2158	4.95	—	—

Std/Med Static 1072-2200 rpm, 3.0 Max bhp

High Static 1072-2200 rpm, 5.0 Max bhp

RAV150 — STANDARD/MEDIUM STATIC — 12.5 TON HORIZONTAL SUPPLY (RPM — VDC)

CFM	AVAILABLE EXTERNAL STATIC PRESSURE (in. wg)									
	0.2		0.4		0.6		0.8		1.0	
	rpm	Vdc	rpm	Vdc	rpm	Vdc	rpm	Vdc	rpm	Vdc
3750	1072	4.8	1166	5.2	1266	5.7	1363	6.1	1454	6.6
4060	1148	5.1	1233	5.5	1324	6.0	1416	6.4	1504	6.8
4375	1226	5.5	1303	5.9	1386	6.2	1472	6.6	1556	7.0
4690	1304	5.9	1374	6.2	1451	6.5	1530	6.9	1610	7.3
5000	1383	6.2	1448	6.5	1518	6.9	1592	7.2	1667	7.5
5310	1463	6.6	1523	6.9	1588	7.2	1656	7.5	1726	7.8
5625	1543	7.0	1599	7.2	1659	7.5	1723	7.8	1789	8.1
5940	1623	7.3	1675	7.6	1732	7.8	1791	8.1	—	—
6250	1704	7.7	1753	7.9	1806	8.2	—	—	—	—

CFM	AVAILABLE EXTERNAL STATIC PRESSURE (in. wg)									
	1.2		1.4		1.6		1.8		2.0	
	rpm	Vdc	rpm	Vdc	rpm	Vdc	rpm	Vdc	rpm	Vdc
3750	1540	7.0	1620	7.3	1694	7.7	1765	8.0	—	—
4060	1587	7.2	1666	7.5	1740	7.9	—	—	—	—
4375	1637	7.4	1713	7.8	1786	8.1	—	—	—	—
4690	1688	7.6	1763	8.0	—	—	—	—	—	—
5000	1741	7.9	—	—	—	—	—	—	—	—
5310	1797	8.1	—	—	—	—	—	—	—	—
5625	—	—	—	—	—	—	—	—	—	—
5940	—	—	—	—	—	—	—	—	—	—
6250	—	—	—	—	—	—	—	—	—	—

Std/Med Static 1072-2200 rpm

Fan data (cont)

RAV150 — HIGH STATIC — 12.5 TON HORIZONTAL SUPPLY (RPM — VDC)

CFM	AVAILABLE EXTERNAL STATIC PRESSURE (in. wg)									
	0.2		0.4		0.6		0.8		1.0	
	rpm	Vdc	rpm	Vdc	rpm	Vdc	rpm	Vdc	rpm	Vdc
3750	1072	4.8	1166	5.2	1266	5.7	1363	6.1	1454	6.6
4060	1148	5.1	1233	5.5	1324	6.0	1416	6.4	1504	6.8
4375	1226	5.5	1303	5.9	1386	6.2	1472	6.6	1556	7.0
4690	1304	5.9	1374	6.2	1451	6.5	1530	6.9	1610	7.3
5000	1383	6.2	1448	6.5	1518	6.9	1592	7.2	1667	7.5
5310	1463	6.6	1523	6.9	1588	7.2	1656	7.5	1726	7.8
5625	1543	7.0	1599	7.2	1659	7.5	1723	7.8	1789	8.1
5940	1623	7.3	1675	7.6	1732	7.8	1791	8.1	1853	8.4
6250	1704	7.7	1753	7.9	1806	8.2	1861	8.4	1919	8.7

CFM	AVAILABLE EXTERNAL STATIC PRESSURE (in. wg)									
	1.2		1.4		1.6		1.8		2.0	
	rpm	Vdc	rpm	Vdc	rpm	Vdc	rpm	Vdc	rpm	Vdc
3750	1540	7.0	1620	7.3	1694	7.7	1765	8.0	1833	8.3
4060	1587	7.2	1666	7.5	1740	7.9	1810	8.2	1877	8.5
4375	1637	7.4	1713	7.8	1786	8.1	1856	8.4	1922	8.7
4690	1688	7.6	1763	8.0	1834	8.3	1902	8.6	1968	8.9
5000	1741	7.9	1813	8.2	1883	8.5	1950	8.8	2015	9.1
5310	1797	8.1	1867	8.5	1934	8.8	2000	9.1	2063	9.4
5625	1855	8.4	1922	8.7	1987	9.0	2050	9.3	2112	9.6
5940	1915	8.7	1979	9.0	2042	9.3	2103	9.6	2163	9.8
6250	1978	9.0	2038	9.3	2098	9.5	2158	9.8	—	—

High Static 1072-2200 rpm

Fan data (cont)

RAV180 — 15 TON HORIZONTAL SUPPLY (RPM — BHP)

CFM	AVAILABLE EXTERNAL STATIC PRESSURE (in. wg)									
	0.2		0.4		0.6		0.8		1.0	
	rpm	bhp	rpm	bhp	rpm	bhp	rpm	bhp	rpm	bhp
4500	1117	0.73	1198	0.90	1278	1.09	1358	1.31	1438	1.55
4875	1205	0.91	1279	1.09	1353	1.29	1427	1.51	1501	1.76
5250	1294	1.12	1363	1.30	1432	1.51	1500	1.74	1569	1.99
5625	1383	1.34	1448	1.54	1512	1.76	1576	1.99	1640	2.24
6000	1473	1.60	1534	1.80	1594	2.02	1654	2.26	1714	2.52
6375	1564	1.88	1621	2.09	1678	2.32	1734	2.56	1791	2.82
6750	1655	2.18	1709	2.40	1762	2.63	1816	2.88	1869	3.14
7125	1746	2.54	1797	2.76	1848	3.01	1899	3.26	1949	3.53
7500	1838	2.97	1886	3.21	1935	3.46	1983	3.73	2031	4.00

CFM	AVAILABLE EXTERNAL STATIC PRESSURE (in. wg)									
	1.2		1.4		1.6		1.8		2.0	
	rpm	bhp	rpm	bhp	rpm	bhp	rpm	bhp	rpm	bhp
4500	1516	1.82	1594	2.12	1670	2.43	1744	2.77	1816	3.13
4875	1575	2.03	1647	2.32	1719	2.64	1790	2.98	1858	3.33
5250	1638	2.26	1706	2.56	1773	2.87	1840	3.21	1905	3.56
5625	1704	2.51	1768	2.81	1832	3.12	1895	3.46	1957	3.81
6000	1775	2.79	1835	3.09	1894	3.39	1954	3.73	2013	4.08
6375	1848	3.09	1904	3.38	1961	3.70	2017	4.02	2073	4.37
6750	1923	3.43	1976	3.72	2030	4.03	2083	4.35	2136	4.69
7125	2000	3.81	2051	4.11	2101	4.42	2152	4.75	—	—
7500	2079	4.29	2127	4.60	2175	4.92	—	—	—	—

Std/Med Static 1117-2200 rpm, 3.0 Max bhp

High Static 1117-2200 rpm, 5.0 Max bhp

RAV180 — STANDARD/MEDIUM STATIC — 15 TON HORIZONTAL SUPPLY (RPM — VDC)

CFM	AVAILABLE EXTERNAL STATIC PRESSURE (in. wg)									
	0.2		0.4		0.6		0.8		1.0	
	rpm	Vdc	rpm	Vdc	rpm	Vdc	rpm	Vdc	rpm	Vdc
4500	1117	5.0	1198	5.4	1278	5.7	1358	6.1	1438	6.5
4875	1205	5.4	1279	5.7	1353	6.1	1427	6.4	1501	6.8
5250	1294	5.8	1363	6.1	1432	6.5	1500	6.8	1569	7.1
5625	1383	6.2	1448	6.5	1512	6.8	1576	7.1	1640	7.4
6000	1473	6.6	1534	6.9	1594	7.2	1654	7.5	1714	7.8
6375	1564	7.1	1621	7.3	1678	7.6	1734	7.8	1791	8.1
6750	1655	7.5	1709	7.7	1762	8.0	1816	8.2	1869	8.5
7125	1746	7.9	1797	8.1	1848	8.4	—	—	—	—
7500	1838	8.3	—	—	—	—	—	—	—	—

CFM	AVAILABLE EXTERNAL STATIC PRESSURE (in. wg)									
	1.2		1.4		1.6		1.8		2.0	
	rpm	Vdc	rpm	Vdc	rpm	Vdc	rpm	Vdc	rpm	Vdc
4500	1516	6.8	1594	7.2	1670	7.6	1744	7.9	—	—
4875	1575	7.1	1647	7.4	1719	7.8	1790	8.1	—	—
5250	1638	7.4	1706	7.7	1773	8.0	—	—	—	—
5625	1704	7.7	1768	8.0	—	—	—	—	—	—
6000	1775	8.0	—	—	—	—	—	—	—	—
6375	—	—	—	—	—	—	—	—	—	—
6750	—	—	—	—	—	—	—	—	—	—
7125	—	—	—	—	—	—	—	—	—	—
7500	—	—	—	—	—	—	—	—	—	—

Std/Med Static 1117-2200 rpm

Fan data (cont)

RAV180 — HIGH STATIC — 15 TON HORIZONTAL SUPPLY (RPM — VDC)

CFM	AVAILABLE EXTERNAL STATIC PRESSURE (in. wg)									
	0.2		0.4		0.6		0.8		1.0	
	rpm	Vdc	rpm	Vdc	rpm	Vdc	rpm	Vdc	rpm	Vdc
4500	1117	5.0	1198	5.4	1278	5.7	1358	6.1	1438	6.5
4875	1205	5.4	1279	5.7	1353	6.1	1427	6.4	1501	6.8
5250	1294	5.8	1363	6.1	1432	6.5	1500	6.8	1569	7.1
5625	1383	6.2	1448	6.5	1512	6.8	1576	7.1	1640	7.4
6000	1473	6.6	1534	6.9	1594	7.2	1654	7.5	1714	7.8
6375	1564	7.1	1621	7.3	1678	7.6	1734	7.8	1791	8.1
6750	1655	7.5	1709	7.7	1762	8.0	1816	8.2	1869	8.5
7125	1746	7.9	1797	8.1	1848	8.4	1899	8.6	1949	8.8
7500	1838	8.3	1886	8.6	1935	8.8	1983	9.0	2031	9.2

CFM	AVAILABLE EXTERNAL STATIC PRESSURE (in. wg)									
	1.2		1.4		1.6		1.8		2.0	
	rpm	Vdc	rpm	Vdc	rpm	Vdc	rpm	Vdc	rpm	Vdc
4500	1516	6.8	1594	7.2	1670	7.6	1744	7.9	1816	8.2
4875	1575	7.1	1647	7.4	1719	7.8	1790	8.1	1858	8.4
5250	1638	7.4	1706	7.7	1773	8.0	1840	8.3	1905	8.6
5625	1704	7.7	1768	8.0	1832	8.3	1895	8.6	1957	8.9
6000	1775	8.0	1835	8.3	1894	8.6	1954	8.9	2013	9.1
6375	1848	8.4	1904	8.6	1961	8.9	2017	9.2	2073	9.4
6750	1923	8.7	1976	9.0	2030	9.2	2083	9.5	2136	9.7
7125	2000	9.1	2051	9.3	2101	9.5	2152	9.8	—	—
7500	2079	9.4	2127	9.7	2175	9.9	—	—	—	—

High Static 1117-2200 rpm

Electrical data

Legend and Notes

Applicable for Electrical Data Tables on pages 101-123

LEGEND

BRKR	— Circuit Breaker
C.O.	— Convenience Outlet
FLA	— Full Load Amps
IFM	— Indoor Fan Motor
LRA	— Locked Rotor Amps
MCA	— Minimum Circuit Amps
P.E.	— Power Exhaust
PWRD C.O.	— Powered Convenience Outlet
RLA	— Rated Load Amps
SCCR	— Short Circuit Current Rating
UNPWR C.O.	— Unpowered Convenience Outlet

NOTES:

1. In compliance with NEC requirements for multi-motor and combination load equipment (refer to NEC Articles 430 and 440), the overcurrent protective device for the unit shall be fuse or HACR breaker. Canadian units may be fuse or circuit breaker.
2. For 208/230 v units, where one value is shown it is the same for either 208 or 230 volts.
3. **Unbalanced 3-Phase Supply Voltage**
Never operate a motor where a phase imbalance in supply voltage is greater than 2%. Use the following formula to determine the percentage of voltage imbalance.

$$\% \text{ Voltage Imbalance} = 100 \times \frac{\text{max voltage deviation from average voltage}}{\text{average voltage}}$$

Example: Supply voltage is 230-3-60

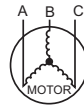

$$AB = 224 \text{ v}$$

$$BC = 231 \text{ v}$$

$$AC = 226 \text{ v}$$

$$\text{Average Voltage} = \frac{(224 + 231 + 226)}{3} = \frac{681}{3} = 227$$

Determine maximum deviation from average voltage.

$$(AB) 227 - 224 = 3 \text{ v}$$

$$(BC) 231 - 227 = 4 \text{ v}$$

$$(AC) 227 - 226 = 1 \text{ v}$$

Maximum deviation is 4 v.

Determine percent of voltage imbalance.

$$\% \text{ Voltage Imbalance} = 100 \times \frac{4}{227} = 1.78\%$$

This amount of phase imbalance is satisfactory as it is below the maximum allowable 2%.

IMPORTANT: If the supply voltage phase imbalance is more than 2%, contact your local electric utility company immediately.

Electrical data (cont)

RGV/RAV090-180 COOLING ELECTRICAL DATA

RGV/RAV UNITSIZE	V-Ph-Hz	UNIT VOLTAGE		COMP 1		COMP 2		OFM (EA)		STD SCCR kA	IFM			COMBUSTION FAN MOTOR (RGV ONLY)	POWER EXHAUST		
		RANGE		RLA	LRA	RLA	LRA	WATTS	FLA		TYPE	EFFCY AT FULL LOAD	FLA		FLA	KIT QTY	FLA (EA KIT)
		MIN	MAX														
090	208-3-60	187	253	13.1	123	13.1	123	325	1.5	5	STD/MED	90%	6.4	0.48	1	3.8	
										HIGH	7.5						
	230-3-60	187	253	13.1	123	13.1	123	325	1.5	5	STD/MED	90%	6.4	0.48	1	3.8	
										HIGH	7.5						
460-3-60	414	506	6.1	60	6.1	60	325	0.8	5	STD/MED	90%	3.0	0.25	1	1.8		
									HIGH	3.5							
575-3-60	518	633	4.6	41	4.6	41	325	0.6	5	STD/MED	90%	2.5	0.24	1	3.8		
									HIGH	3.0							
102	208-3-60	187	253	13.7	123	13.7	123	325	1.5	5	STD/MED	90%	6.4	0.48	1	3.8	
										HIGH	7.5						
	230-3-60	187	253	13.7	123	13.7	123	325	1.5	5	STD/MED	90%	6.4	0.48	1	3.8	
										HIGH	7.5						
460-3-60	414	506	6.2	60	6.2	60	325	0.8	5	STD/MED	90%	3.0	0.25	1	1.8		
									HIGH	3.5							
575-3-60	518	633	4.8	41	4.8	41	325	0.6	5	STD/MED	90%	2.5	0.24	1	3.8		
									HIGH	3.0							
120	208-3-60	187	253	15.6	110	15.6	110	325	1.5	5	STD/MED	90%	6.4	0.48	1	3.8	
										HIGH	12.6						
	230-3-60	187	253	15.6	110	15.6	110	325	1.5	5	STD/MED	90%	6.4	0.48	1	3.8	
										HIGH	12.6						
460-3-60	414	506	7.7	60	7.7	60	325	0.8	5	STD/MED	90%	3.0	0.25	1	1.8		
									HIGH	5.6							
575-3-60	518	633	5.9	41	5.9	41	325	0.6	5	STD/MED	90%	2.5	0.24	1	3.8		
									HIGH	4.6							
150	208-3-60	187	253	22.4	149	19.6	136	1070	7.4	5	STD/MED	90%	7.5	0.48	1	3.8	
										HIGH	12.6						
	230-3-60	187	253	22.4	149	19.6	136	1070	7.4	5	STD/MED	90%	7.5	0.48	1	3.8	
										HIGH	12.6						
460-3-60	414	506	10.6	75	8.2	66	1070	7.4	5	STD/MED	90%	3.5	0.25	1	1.8		
									HIGH	5.6							
575-3-60	518	633	7.7	54	6.6	55	1070	7.4	5	STD/MED	90%	3.0	0.24	1	3.8		
									HIGH	4.6							
180	208-3-60	187	253	28.2	239	19.6	136	280	1.5	5	STD/MED	90%	7.5	0.48	1	3.8	
										HIGH	12.6						
	230-3-60	187	253	28.2	239	19.6	136	280	1.5	5	STD/MED	90%	7.5	0.48	1	3.8	
										HIGH	12.6						
460-3-60	414	506	14.7	130	8.2	66	280	0.8	5	STD/MED	90%	3.5	0.25	1	1.8		
									HIGH	5.6							
575-3-60	518	633	11.3	94	6.6	55	280	0.6	5	STD/MED	90%	3.0	0.24	1	3.8		
									HIGH	4.6							

Electrical data (cont)

RGV090-180 MCA MOCP ELECTRICAL DATA

RGV UNIT SIZE	NOM. V-Ph-Hz	IFM TYPE	STD SCCR kA	NO CONVENIENCE OUTLET OR UNPOWERED CONVENIENCE OUTLET							
				NO POWER EXHAUST				w/ POWER EXHAUST (powered from unit)			
				MCA	FUSE OR HACR BREAKER	DISCONNECT SIZE		MCA	FUSE OR HACR BREAKER	DISCONNECT SIZE	
						FLA	LRA			FLA	LRA
RGV090	208/230-3-60	STD/MED	5	39	50	41	263	43	50	45	267
		HIGH	5	40	50	42	265	44	50	47	269
	460-3-60	STD/MED	5	19	20	19	128	21	25	21	130
		HIGH	5	19	25	20	131	21	25	22	133
	575-3-60	STD/MED	5	15	20	15	90	18	20	19	94
		HIGH	5	15	20	15	91	19	20	20	95
RGV102	208/230-3-60	STD/MED	5	41	50	42	263	44	50	47	267
		HIGH	5	42	50	44	265	46	50	48	269
	460-3-60	STD/MED	5	19	25	20	128	21	25	22	130
		HIGH	5	20	25	20	131	21	25	22	133
	575-3-60	STD/MED	5	15	20	15	90	19	20	20	94
		HIGH	5	15	20	16	91	19	25	20	95
RGV120	208/230-3-60	STD/MED	5	45	60	47	237	49	60	51	241
		HIGH	5	51	60	54	246	55	60	58	250
	460-3-60	STD/MED	5	22	25	23	128	24	30	25	130
		HIGH	5	25	30	26	132	27	30	28	134
	575-3-60	STD/MED	5	17	20	18	90	21	25	22	94
		HIGH	5	20	25	20	92	23	25	25	96
RGV150	208/230-3-60	STD/MED	5	63	80	65	303	67	80	70	307
		HIGH	5	68	80	71	310	72	80	76	314
	460-3-60	STD/MED	5	33	40	34	155	35	40	36	157
		HIGH	5	35	45	37	156	37	45	39	158
	575-3-60	STD/MED	5	27	30	28	121	31	35	33	125
		HIGH	5	29	35	30	122	32	35	35	126
RGV180	208/230-3-60	STD/MED	5	67	80	69	398	71	80	73	402
		HIGH	5	72	80	75	405	76	100	79	409
	460-3-60	STD/MED	5	33	45	33	209	35	45	35	211
		HIGH	5	35	45	36	210	37	50	38	212
	575-3-60	STD/MED	5	26	30	26	160	30	40	30	164
		HIGH	5	28	30	28	161	31	40	32	165

Electrical data (cont)

RGV090-180 MCA MOCPP ELECTRICAL DATA (cont)

RGV UNIT SIZE	NOM. V-Ph-Hz	IFM TYPE	STD SCCR kA	w/ POWERED CONVENIENCE OUTLET							
				NO POWER EXHAUST				w/ POWER EXHAUST (powered from unit)			
				MCA	FUSE OR HACR BREAKER	DISCONNECT SIZE		MCA	FUSE OR HACR BREAKER	DISCONNECT SIZE	
FLA	LRA	FLA	LRA								
RGV090	208/230-3-60	STD/MED	5	44	50	46	268	48	60	51	272
		HIGH	5	45	50	48	270	49	60	52	274
	460-3-60	STD/MED	5	21	25	22	130	23	25	24	132
		HIGH	5	21	25	22	133	23	25	24	135
	575-3-60	STD/MED	5	16	20	17	92	20	25	21	96
		HIGH	5	17	20	17	93	21	25	22	97
RGV102	208/230-3-60	STD/MED	5	45	50	48	268	49	60	52	272
		HIGH	5	47	50	49	270	50	60	53	274
	460-3-60	STD/MED	5	21	25	22	130	23	25	24	132
		HIGH	5	22	25	23	133	24	25	25	135
	575-3-60	STD/MED	5	17	20	17	92	20	25	22	96
		HIGH	5	17	20	18	93	21	25	22	97
RGV120	208/230-3-60	STD/MED	5	50	60	52	242	54	60	57	246
		HIGH	5	56	60	59	251	60	70	64	255
	460-3-60	STD/MED	5	25	30	26	130	26	30	28	132
		HIGH	5	27	30	29	134	29	35	31	136
	575-3-60	STD/MED	5	19	25	20	92	23	25	24	96
		HIGH	5	21	25	22	94	25	30	27	98
RGV150	208/230-3-60	STD/MED	5	68	80	71	308	72	80	75	312
		HIGH	5	73	80	77	315	—	—	—	—
	460-3-60	STD/MED	5	35	45	37	157	37	45	39	159
		HIGH	5	37	45	39	158	39	45	41	160
	575-3-60	STD/MED	5	29	35	30	123	33	35	35	127
		HIGH	5	30	35	32	124	34	40	37	128
RGV180	208/230-3-60	STD/MED	5	72	80	74	403	76	100	79	407
		HIGH	5	77	100	80	410	81	100	85	414
	460-3-60	STD/MED	5	35	45	36	211	37	50	38	213
		HIGH	5	37	50	38	212	39	50	40	214
	575-3-60	STD/MED	5	28	35	28	162	31	40	32	166
		HIGH	5	29	40	30	163	33	40	34	167

Electrical data (cont)

RAV090 MCA MOCP ELECTRICAL DATA

RAV UNIT SIZE	NOM. V-Ph-Hz	IFM TYPE	STD SCCR KA	ELECTRIC HEATER			NO CONVENIENCE OUTLET or UNPOWERED CONVENIENCE OUTLET							
				CRHEATER ****00	NOM (kW)	FLA	NO POWER EXHAUST				w/ POWER EXHAUST (powered from unit)			
							MCA	FUSE OR HACR BRKR	DISCONNECT SIZE		MCA	FUSE OR HACR BRKR	DISCONNECT SIZE	
									FLA	LRA			FLA	LRA
RAV090	208/230-3-60	STD/ MED	5	—	—	—	39	50	41	263	43	50	45	267
				411A	7.8/10.4	21.7/25.0	39/40	50/50	41/41	263/263	43/44	50/50	45/45	267/267
				412A	12.0/16.0	33.4/38.5	50/57	50/60	46/52	263/263	55/61	60/70	50/56	267/267
				414A	18.8/25.0	52.1/60.1	74/84	80/90	67/76	263/263	78/88	80/90	72/81	267/267
				415A	24.0/32.0	66.7/77.0	92/105	100/110	84/96	263/263	97/109	100/110	88/100	267/267
		416A	31.8/42.4	88.4/102.0	119/136	125/150	109/125	263/263	124/141	125/150	113/129	267/267		
		HIGH	5	—	—	—	40	50	42	265	44	50	47	269
				411A	7.8/10.4	21.7/25.0	40/41	50/50	42/42	265/265	44/46	50/50	47/47	269/269
				412A	12.0/16.0	33.4/38.5	52/58	60/60	47/53	265/265	56/63	60/70	51/57	269/269
				414A	18.8/25.0	52.1/60.1	75/85	80/90	69/78	265/265	80/90	80/90	73/82	269/269
	415A			24.0/32.0	66.7/77.0	93/106	100/110	85/97	265/265	98/111	100/125	90/102	269/269	
	416A	31.8/42.4	88.4/102.0	120/137	125/150	110/126	265/265	125/142	125/150	115/130	269/269			
	460-3-60	STD/ MED	5	—	—	—	19	20	19	128	21	25	21	130
				420A	15.0	18.0	27	30	24	128	29	30	26	130
				421A	25.0	30.1	42	45	38	128	44	45	40	130
				422A	33.0	39.7	54	60	49	128	56	60	51	130
				423A	41.7	50.2	67	70	61	128	69	70	63	130
		HIGH	5	—	—	—	19	25	20	131	21	25	22	133
				420A	15.0	18.0	27	30	25	131	30	30	27	133
				421A	25.0	30.1	42	45	39	131	45	45	41	133
				422A	33.0	39.7	54	60	50	131	57	60	52	133
				423A	41.7	50.2	68	70	62	131	70	70	64	133
	575-3-60	STD/ MED	5	—	—	—	15	20	15	90	18	20	19	94
				425A	18.0	17.3	25	25	23	90	30	30	27	94
				427A	36.0	34.6	47	50	43	90	52	60	47	94
		HIGH	5	—	—	—	15	20	15	91	19	20	20	95
				425A	18.0	17.3	26	30	23	91	31	35	28	95
				427A	36.0	34.6	47	50	43	91	52	60	48	95

Electrical data (cont)

RAV090 MCA MOCP ELECTRICAL DATA (cont)

RAV UNIT SIZE	NOM. V-Ph-Hz	IFM TYPE	STD SCCR kA	ELECTRIC HEATER			w/ POWERED CONVENIENCE OUTLET							
				CRHEATER ****00	NOM (kW)	FLA	NO POWER EXHAUST				w/ POWER EXHAUST (powered from unit)			
							MCA	FUSE OR HACR BRKR	DISCONNECT SIZE		MCA	FUSE OR HACR BRKR	DISCONNECT SIZE	
									FLA	LRA			FLA	LRA
RAV090	208/230-3-60	STD/MED	5	—	—	—	44	50	46	268	48	60	51	272
				411A	7.8/10.4	21.7/25.0	44/46	50/50	46/46	268/268	48/50	60/60	51/51	272/272
				412A	12.0/16.0	33.4/38.5	56/63	60/70	51/57	268/268	61/67	70/70	56/62	272/272
				414A	18.8/25.0	52.1/60.1	80/90	80/90	73/82	268/268	84/94	90/100	77/86	272/272
				415A	24.0/32.0	66.7/77.0	98/111	100/125	90/101	268/268	103/115	110/125	94/106	272/272
		416A	31.8/42.4	88.4/102.0	125/142	125/150	115/130	268/268	130/147	150/150	119/135	272/272		
		HIGH	5	—	—	—	45	50	48	270	49	60	52	274
				411A	7.8/10.4	21.7/25.0	45/47	50/50	48/48	270/270	49/52	60/60	52/52	274/274
				412A	12.0/16.0	33.4/38.5	58/64	60/70	53/58	270/270	62/69	70/70	57/63	274/274
				414A	18.8/25.0	52.1/60.1	81/91	90/100	74/83	270/270	86/96	90/100	78/88	274/274
	415A			24.0/32.0	66.7/77.0	99/112	100/125	91/103	270/270	104/117	110/125	95/107	274/274	
	416A	31.8/42.4	88.4/102.0	126/143	150/150	116/131	270/270	131/148	150/150	120/136	274/274			
	460-3-60	STD/MED	5	—	—	—	21	25	22	130	23	25	24	132
				420A	15.0	18.0	29	30	27	130	32	35	29	132
				421A	25.0	30.1	45	45	41	130	47	50	43	132
				422A	33.0	39.7	57	60	52	130	59	60	54	132
				423A	41.7	50.2	70	70	64	130	72	80	66	132
		HIGH	5	—	—	—	21	25	22	133	23	25	24	135
				420A	15.0	18.0	30	30	27	133	32	35	29	135
				421A	25.0	30.1	45	45	41	133	47	50	43	135
				422A	33.0	39.7	57	60	52	133	59	60	54	135
				423A	41.7	50.2	70	70	64	133	73	80	66	135
	575-3-60	STD/MED	5	—	—	—	16	20	17	92	20	25	21	96
				425A	18.0	17.3	27	30	25	92	32	35	29	96
427A				36.0	34.6	49	50	45	92	54	60	49	96	
HIGH		5	—	—	—	17	20	17	93	21	25	22	97	
			425A	18.0	17.3	28	30	25	93	33	35	30	97	
			427A	36.0	34.6	50	50	45	93	54	60	50	97	

Electrical data (cont)

RAV102 MCA MOCP ELECTRICAL DATA

RAV UNIT SIZE	NOM. V-Ph-Hz	IFM TYPE	STD SCCR KA	ELECTRIC HEATER			NO CONVENIENCE OUTLET or UNPOWERED CONVENIENCE OUTLET							
				CRHEATER ****00	NOM (kW)	FLA	NO POWER EXHAUST				w/ POWER EXHAUST (powered from unit)			
							MCA	FUSE OR HACR BRKR	DISCONNECT SIZE		MCA	FUSE OR HACR BRKR	DISCONNECT SIZE	
									FLA	LRA			FLA	LRA
RAV102	208/230-3-60	STD/MED	5	—	—	—	41	50	42	263	44	50	47	267
				411A	7.8/10.4	21.7/25.0	41/41	50/50	42/42	263/263	44/44	50/50	47/47	267/267
				412A	12.0/16.0	33.4/38.5	50/57	50/60	46/52	263/263	55/61	60/70	50/56	267/267
				414A	18.8/25.0	52.1/60.1	74/84	80/90	67/76	263/263	78/88	80/90	72/81	267/267
				415A	24.0/32.0	66.7/77.0	92/105	100/110	84/96	263/263	97/109	100/110	88/100	267/267
		416A	31.8/42.4	88.4/102.0	119/136	125/150	109/125	263/263	124/141	125/150	113/129	267/267		
		HIGH	5	—	—	—	42	50	44	265	46	50	48	269
				411A	7.8/10.4	21.7/25.0	42/42	50/50	44/44	265/265	46/46	50/50	48/48	269/269
				412A	12.0/16.0	33.4/38.5	52/58	60/60	47/53	265/265	56/63	60/70	51/57	269/269
				414A	18.8/25.0	52.1/60.1	75/85	80/90	69/78	265/265	80/90	80/90	73/82	269/269
	415A			24.0/32.0	66.7/77.0	93/106	100/110	85/97	265/265	98/111	100/125	90/102	269/269	
	416A	31.8/42.4	88.4/102.0	120/137	125/150	110/126	265/265	125/142	125/150	115/130	269/269			
	460-3-60	STD/MED	5	—	—	—	19	25	20	128	21	25	22	130
				420A	15.0	18.0	27	30	24	128	29	30	26	130
				421A	25.0	30.1	42	45	38	128	44	45	40	130
				422A	33.0	39.7	54	60	49	128	56	60	51	130
				423A	41.7	50.2	67	70	61	128	69	70	63	130
		HIGH	5	—	—	—	20	25	20	131	21	25	22	133
				420A	15.0	18.0	27	30	25	131	30	30	27	133
				421A	25.0	30.1	42	45	39	131	45	45	41	133
				422A	33.0	39.7	54	60	50	131	57	60	52	133
				423A	41.7	50.2	68	70	62	131	70	70	64	133
	575-3-60	STD/MED	5	—	—	—	15	20	15	90	19	20	20	94
				425A	18.0	17.3	25	25	23	90	30	30	27	94
427A				36.0	34.6	47	50	43	90	52	60	47	94	
HIGH		5	—	—	—	15	20	16	91	19	25	20	95	
			425A	18.0	17.3	26	30	23	91	31	35	28	95	
			427A	36.0	34.6	47	50	43	91	52	60	48	95	

Electrical data (cont)

RAV102 MCA MOCP ELECTRICAL DATA (cont)

RAV UNIT SIZE	NOM. V-Ph-Hz	IFM TYPE	STD SCCR KA	ELECTRIC HEATER			w/ POWERED CONVENIENCE OUTLET							
				CRHEATER ****00	NOM (kW)	FLA	NO POWER EXHAUST				w/ POWER EXHAUST (powered from unit)			
							MCA	FUSE OR HACR BRKR	DISCONNECT SIZE		MCA	FUSE OR HACR BRKR	DISCONNECT SIZE	
									FLA	LRA			FLA	LRA
RAV102	208/230-3-60	STD/MED	5	—	—	—	45	50	48	268	49	60	52	272
				411A	7.8/10.4	21.7/25.0	45/46	50/50	48/48	268/268	49/50	60/60	52/52	272/272
				412A	12.0/16.0	33.4/38.5	56/63	60/70	51/57	268/268	61/67	70/70	56/62	272/272
				414A	18.8/25.0	52.1/60.1	80/90	80/90	73/82	268/268	84/94	90/100	77/86	272/272
				415A	24.0/32.0	66.7/77.0	98/111	100/125	90/101	268/268	103/115	110/125	94/106	272/272
				416A	31.8/42.4	88.4/102.0	125/142	125/150	115/130	268/268	130/147	150/150	119/135	272/272
		HIGH	5	—	—	—	47	50	49	270	50	60	53	274
				411A	7.8/10.4	21.7/25.0	47/47	50/50	49/49	270/270	50/52	60/60	53/53	274/274
				412A	12.0/16.0	33.4/38.5	58/64	60/70	53/58	270/270	62/69	70/70	57/63	274/274
				414A	18.8/25.0	52.1/60.1	81/91	90/100	74/83	270/270	86/96	90/100	78/88	274/274
				415A	24.0/32.0	66.7/77.0	99/112	100/125	91/103	270/270	104/117	110/125	95/107	274/274
				416A	31.8/42.4	88.4/102.0	126/143	150/150	116/131	270/270	131/148	150/150	120/136	274/274
	460-3-60	STD/MED	5	—	—	—	21	25	22	130	23	25	24	132
				420A	15.0	18.0	29	30	27	130	32	35	29	132
				421A	25.0	30.1	45	45	41	130	47	50	43	132
				422A	33.0	39.7	57	60	52	130	59	60	54	132
				423A	41.7	50.2	70	70	64	130	72	80	66	132
				—	—	—	22	25	23	133	24	25	25	135
		HIGH	5	420A	15.0	18.0	30	30	27	133	32	35	29	135
				421A	25.0	30.1	45	45	41	133	47	50	43	135
				422A	33.0	39.7	57	60	52	133	59	60	54	135
				423A	41.7	50.2	70	70	64	133	73	80	66	135
				—	—	—	17	20	17	92	20	25	22	96
				425A	18.0	17.3	27	30	25	92	32	35	29	96
575-3-60	STD/MED	5	427A	36.0	34.6	49	50	45	92	54	60	49	96	
			—	—	—	17	20	18	93	21	25	22	97	
			425A	18.0	17.3	28	30	25	93	33	35	30	97	
	HIGH	5	427A	36.0	34.6	50	50	45	93	54	60	50	97	

Electrical data (cont)

RAV120 MCA MOCP ELECTRICAL DATA

RAV UNIT SIZE	NOM. V-Ph-Hz	IFM TYPE	STD SCCR KA	ELECTRIC HEATER			NO CONVENIENCE OUTLET or UNPOWERED CONVENIENCE OUTLET							
				CRHEATER ****00	NOM (kW)	FLA	NO POWER EXHAUST				w/ POWER EXHAUST (powered from unit)			
							MCA	FUSE OR HACR BRKR	DISCONNECT SIZE		MCA	FUSE OR HACR BRKR	DISCONNECT SIZE	
									FLA	LRA			FLA	LRA
RAV120	208/230-3-60	STD/ MED	5	—	—	—	45	60	47	237	49	60	51	241
				411A	7.8/10.4	21.7/25.0	45/45	60/60	47/47	237/237	49/49	60/60	51/51	241/241
				412A	12.0/16.0	33.4/38.5	50/57	60/60	47/52	237/237	55/61	60/70	51/56	241/241
				415A	24.0/32.0	66.7/77.0	92/105	100/110	84/96	237/237	97/109	100/110	88/100	241/241
				416A	31.8/42.4	88.4/102.0	119/136	125/150	109/125	237/237	124/141	125/150	113/129	241/241
		417A	37.6/50.0	104.2/120.3	139/159	150/175	127/146	237/237	143/164	150/175	132/150	241/241		
		HIGH	5	—	—	—	51	60	54	246	55	60	58	250
				411A	7.8/10.4	21.7/25.0	51/51	60/60	54/54	246/246	55/55	60/60	58/58	250/250
				412A	12.0/16.0	33.4/38.5	58/64	60/70	54/59	246/246	63/69	70/70	58/63	250/250
				415A	24.0/32.0	66.7/77.0	100/112	100/125	91/103	246/246	104/117	110/125	96/107	250/250
	416A			31.8/42.4	88.4/102.0	127/144	150/150	116/132	246/246	131/148	150/150	121/136	250/250	
	417A	37.6/50.0	104.2/120.3	146/167	150/175	134/153	246/246	151/171	175/175	139/157	250/250			
	460-3-60	STD/ MED	5	—	—	—	22	25	23	128	24	30	25	130
				420A	15.0	18.0	27	30	24	128	29	30	26	130
				422A	33.0	39.7	54	60	49	128	56	60	51	130
				423A	41.7	50.2	67	70	61	128	69	70	63	130
				424A	50.0	60.1	79	80	73	128	82	90	75	130
		HIGH	5	—	—	—	25	30	26	132	27	30	28	134
				420A	15.0	18.0	30	30	27	132	32	35	29	134
				422A	33.0	39.7	57	60	52	132	59	60	54	134
				423A	41.7	50.2	70	70	64	132	72	80	66	134
				424A	50.0	60.1	83	90	76	132	85	90	78	134
	575-3-60	STD/ MED	5	—	—	—	17	20	18	90	21	25	22	94
				425A	18.0	17.3	25	25	23	90	30	30	27	94
427A				36.0	34.6	47	50	43	90	52	60	47	94	
428A				50.0	48.1	64	70	58	90	68	70	63	94	
HIGH		5	—	—	—	20	25	20	92	23	25	25	96	
			425A	18.0	17.3	28	30	25	92	33	35	30	96	
			427A	36.0	34.6	49	50	45	92	54	60	49	96	
			428A	50.0	48.1	66	70	61	92	71	80	65	96	

Electrical data (cont)

RAV120 MCA MOCP ELECTRICAL DATA (cont)

RAV UNIT SIZE	NOM. V-Ph-Hz	IFM TYPE	STD SCCR KA	ELECTRIC HEATER			w/ POWERED CONVENIENCE OUTLET							
				CRHEATER ****00	NOM (kW)	FLA	NO POWER EXHAUST				w/ POWER EXHAUST (powered from unit)			
							MCA	FUSE OR HACR BRKR	DISCONNECT SIZE		MCA	FUSE OR HACR BRKR	DISCONNECT SIZE	
									FLA	LRA			FLA	LRA
RAV120	208/230-3-60	STD/ MED	5	—	—	—	50	60	52	242	54	60	57	246
				411A	7.8/10.4	21.7/25.0	50/50	60/60	52/52	242/242	54/54	60/60	57/57	246/246
				412A	12.0/16.0	33.4/38.5	56/63	60/70	52/57	242/242	61/67	70/70	57/62	246/246
				415A	24.0/32.0	66.7/77.0	98/111	100/125	90/101	242/242	103/115	110/125	94/106	246/246
				416A	31.8/42.4	88.4/102.0	125/142	125/150	115/130	242/242	130/147	150/150	119/135	246/246
		417A	37.6/50.0	104.2/120.3	145/165	150/175	133/151	242/242	149/170	150/175	137/156	246/246		
		HIGH	5	—	—	—	56	60	59	251	60	70	64	255
				411A	7.8/10.4	21.7/25.0	56/56	60/60	59/59	251/251	60/60	70/70	64/64	255/255
				412A	12.0/16.0	33.4/38.5	64/70	70/70	59/64	251/251	69/75	70/80	64/69	255/255
				415A	24.0/32.0	66.7/77.0	106/118	110/125	97/109	251/251	110/123	110/125	101/113	255/255
	416A			31.8/42.4	88.4/102.0	133/150	150/150	122/137	251/251	137/154	150/175	126/142	255/255	
	460-3-60	STD/ MED	5	—	—	—	25	30	26	130	26	30	28	132
				420A	15.0	18.0	29	30	27	130	32	35	29	132
				422A	33.0	39.7	57	60	52	130	59	60	54	132
				423A	41.7	50.2	70	70	64	130	72	80	66	132
				424A	50.0	60.1	82	90	75	130	84	90	77	132
		HIGH	5	—	—	—	27	30	29	134	29	35	31	136
				420A	15.0	18.0	33	35	30	134	35	35	32	136
				422A	33.0	39.7	60	60	55	134	62	70	57	136
				423A	41.7	50.2	73	80	67	134	75	80	69	136
				424A	50.0	60.1	85	90	78	134	88	90	80	136
	575-3-60	STD/ MED	5	—	—	—	19	25	20	92	23	25	24	96
				425A	18.0	17.3	27	30	25	92	32	35	29	96
				427A	36.0	34.6	49	50	45	92	54	60	49	96
				428A	50.0	48.1	66	70	60	92	71	80	65	96
				—	—	—	21	25	22	94	25	30	27	98
		HIGH	5	425A	18.0	17.3	30	30	27	94	35	35	32	98
				427A	36.0	34.6	52	60	47	94	56	60	51	98
428A				50.0	48.1	68	70	63	94	73	80	67	98	

Electrical data (cont)

RAV150 MCA MOCP ELECTRICAL DATA

RAV UNIT SIZE	NOM. V-Ph-Hz	IFM TYPE	STD SCCR KA	ELECTRIC HEATER			NO CONVENIENCE OUTLET or UNPOWERED CONVENIENCE OUTLET							
				CRHEATER ****00	NOM (kW)	FLA	NO POWER EXHAUST				w/ POWER EXHAUST (powered from unit)			
							MCA	FUSE OR HACR BRKR	DISCONNECT SIZE		MCA	FUSE OR HACR BRKR	DISCONNECT SIZE	
									FLA	LRA			FLA	LRA
RAV150	208/230-3-60	STD/ MED	5	—	—	—	63	80	65	303	67	80	70	307
				411A	7.8/10.4	21.7/25.0	63/63	80/80	65/65	303/303	67/67	80/80	70/70	307/307
				412A	12.0/16.0	33.4/38.5	63/63	80/80	65/65	303/303	67/67	80/80	70/70	307/307
				415A	24.0/32.0	66.7/77.0	93/106	100/110	85/97	303/303	98/111	100/125	90/102	307/307
				416A	31.8/42.4	88.4/102.0	120/137	125/150	110/126	303/303	125/142	125/150	115/130	307/307
		417A	37.6/50.0	104.2/120.3	140/160	150/175	128/147	303/303	145/165	150/175	133/151	307/307		
		HIGH	5	—	—	—	68	80	71	310	72	80	76	314
				411A	7.8/10.4	21.7/25.0	68/68	80/80	71/71	310/310	72/72	80/80	76/76	314/314
				412A	12.0/16.0	33.4/38.5	68/68	80/80	71/71	310/310	72/72	80/80	76/76	314/314
				415A	24.0/32.0	66.7/77.0	100/112	100/125	91/103	310/310	104/117	110/125	96/107	314/314
	416A			31.8/42.4	88.4/102.0	127/144	150/150	116/132	310/310	131/148	150/150	121/136	314/314	
	417A	37.6/50.0	104.2/120.3	146/167	150/175	134/153	310/310	151/171	175/175	139/157	314/314			
	460-3-60	STD/ MED	5	—	—	—	33	40	34	155	35	40	36	157
				420A	15.0	18.0	33	40	34	155	35	40	36	157
				422A	33.0	39.7	54	60	50	155	57	60	52	157
				423A	41.7	50.2	68	70	62	155	70	70	64	157
				424A	50.0	60.1	80	80	73	155	82	90	75	157
		HIGH	5	—	—	—	35	45	37	156	37	45	39	158
				420A	15.0	18.0	35	45	37	156	37	45	39	158
				422A	33.0	39.7	57	60	52	156	59	60	54	158
				423A	41.7	50.2	70	70	64	156	72	80	66	158
				424A	50.0	60.1	83	90	76	156	85	90	78	158
	575-3-60	STD/ MED	5	—	—	—	27	30	28	121	31	35	33	125
				425A	18.0	17.3	27	30	28	121	31	35	33	125
427A				36.0	34.6	47	50	43	121	52	60	48	125	
428A				50.0	48.1	64	70	59	121	69	70	63	125	
HIGH		5	—	—	—	29	35	30	122	32	35	35	126	
			425A	18.0	17.3	29	35	30	122	33	35	35	126	
			427A	36.0	34.6	49	50	45	122	54	60	49	126	
			428A	50.0	48.1	66	70	61	122	71	80	65	126	

Electrical data (cont)

RAV150 MCA MOCP ELECTRICAL DATA (cont)

RAV UNIT SIZE	NOM. V-Ph-Hz	IFM TYPE	STD SCCR KA	ELECTRIC HEATER			w/ POWERED CONVENIENCE OUTLET							
				CRHEATER ****00	NOM (KW)	FLA	NO POWER EXHAUST				w/ POWER EXHAUST (powered from unit)			
							MCA	FUSE OR HACR BRKR	DISCONNECT SIZE		MCA	FUSE OR HACR BRKR	DISCONNECT SIZE	
									FLA	LRA			FLA	LRA
RAV150	208/230-3-60	STD/MED	5	—	—	—	68	80	71	308	72	80	75	312
				411A	7.8/10.4	21.7/25.0	68/68	80/80	71/71	308/308	72/72	80/80	75/75	312/312
				412A	12.0/16.0	33.4/38.5	68/68	80/80	71/71	308/308	72/72	80/80	75/75	312/312
				415A	24.0/32.0	66.7/77.0	99/112	100/125	91/103	308/308	104/117	110/125	95/107	312/312
				416A	31.8/42.4	88.4/102.0	126/143	150/150	116/131	308/308	131/148	150/150	120/136	312/312
		417A	37.6/50.0	104.2/120.3	146/166	150/175	134/152	308/308	151/171	175/175	138/157	312/312		
		HIGH	5	—	—	—	73	80	77	315	77	90	81	319
				411A	7.8/10.4	21.7/25.0	73/73	80/80	77/77	315/315	77/77	90/90	81/81	319/319
				412A	12.0/16.0	33.4/38.5	73/73	80/80	77/77	315/315	77/77	90/90	81/81	319/319
				415A	24.0/32.0	66.7/77.0	106/118	110/125	97/109	315/315	110/123	110/125	101/113	319/319
	416A			31.8/42.4	88.4/102.0	133/150	150/150	122/137	315/315	137/154	150/175	126/142	319/319	
	460-3-60	STD/MED	5	—	—	—	35	45	37	157	37	45	39	159
				420A	15.0	18.0	35	45	37	157	37	45	39	159
				422A	33.0	39.7	57	60	52	157	59	60	54	159
				423A	41.7	50.2	70	70	64	157	73	80	66	159
				424A	50.0	60.1	83	90	76	157	85	90	78	159
		HIGH	5	—	—	—	37	45	39	158	39	45	41	160
				420A	15.0	18.0	37	45	39	158	39	45	41	160
				422A	33.0	39.7	60	60	55	158	62	70	57	160
				423A	41.7	50.2	73	80	67	158	75	80	69	160
				424A	50.0	60.1	85	90	78	158	88	90	80	160
	575-3-60	STD/MED	5	—	—	—	29	35	30	123	33	35	35	127
				425A	18.0	17.3	29	35	30	123	33	35	35	127
				427A	36.0	34.6	50	50	45	123	54	60	50	127
428A				50.0	48.1	66	70	61	123	71	80	65	127	
HIGH		5	—	—	—	30	35	32	124	34	40	37	128	
			425A	18.0	17.3	30	35	32	124	35	40	37	128	
			427A	36.0	34.6	52	60	47	124	56	60	51	128	
			428A	50.0	48.1	68	70	63	124	73	80	67	128	

Electrical data (cont)

RAV180 MCA MOCP ELECTRICAL DATA

RAV UNIT SIZE	NOM. V-Ph-Hz	IFM TYPE	STD SCCR kA	ELECTRIC HEATER			NO CONVENIENCE OUTLET or UNPOWERED CONVENIENCE OUTLET							
				CRHEATER ****00	NOM (kW)	FLA	NO POWER EXHAUST				w/ POWER EXHAUST (powered from unit)			
							MCA	FUSE OR HACR BRKR	DISCONNECT SIZE		MCA	FUSE OR HACR BRKR	DISCONNECT SIZE	
									FLA	LRA			FLA	LRA
RAV180	208/230-3-60	STD/MED	5	—	—	—	67	80	69	398	71	80	73	402
				412A	12.0/16.0	33.4/38.5	67/67	80/80	69/69	398/398	71/71	80/80	73/73	402/402
				414A	18.8/25.0	52.1/60.1	75/85	80/90	69/78	398/398	80/90	80/90	73/82	402/402
				415A	24.0/32.0	66.7/77.0	93/106	100/110	85/97	398/398	98/111	100/125	90/102	402/402
				416A	31.8/42.4	88.4/102.0	120/137	125/150	110/126	398/398	125/142	125/150	115/130	402/402
				417A	37.6/50.0	104.2/120.3	140/160	150/175	128/147	398/398	145/165	150/175	133/151	402/402
		451A	50.3/67.0	139.7/161.2	184/211	200/225	169/194	398/398	189/216	200/225	174/198	402/402		
		HIGH	5	—	—	—	72	80	75	405	76	100	79	409
				412A	12.0/16.0	33.4/38.5	72/72	80/80	75/75	405/405	76/76	100/100	79/79	409/409
				414A	18.8/25.0	52.1/60.1	81/91	100/100	75/84	405/405	86/96	100/100	79/88	409/409
				415A	24.0/32.0	66.7/77.0	100/112	100/125	91/103	405/405	104/117	110/125	96/107	409/409
				416A	31.8/42.4	88.4/102.0	127/144	150/150	116/132	405/405	131/148	150/150	121/136	409/409
	417A			37.6/50.0	104.2/120.3	146/167	150/175	134/153	405/405	151/171	175/175	139/157	409/409	
	451A	50.3/67.0	139.7/161.2	191/218	200/225	175/200	405/405	196/222	200/225	180/204	409/409			
	460-3-60	STD/MED	5	—	—	—	33	45	33	209	35	45	35	211
				420A	15.0	18.0	33	45	33	209	35	45	35	211
				421A	25.0	30.1	42	45	39	209	45	45	41	211
				422A	33.0	39.7	54	60	50	209	57	60	52	211
				423A	41.7	50.2	68	70	62	209	70	70	64	211
				424A	50.0	60.1	80	80	73	209	82	90	75	211
		452A	67.0	80.6	106	110	97	209	108	110	99	211		
		HIGH	5	—	—	—	35	45	36	210	37	50	38	212
				420A	15.0	18.0	35	45	36	210	37	50	38	212
				421A	25.0	30.1	45	45	41	210	47	50	43	212
				422A	33.0	39.7	57	60	52	210	59	60	54	212
				423A	41.7	50.2	70	70	64	210	72	80	66	212
	424A			50.0	60.1	83	90	76	210	85	90	78	212	
	452A	67.0	80.6	108	110	99	210	110	125	101	212			
575-3-60	STD/MED	5	—	—	—	26	30	26	160	30	40	30	164	
			425A	18.0	17.3	26	30	26	160	31	40	30	164	
			427A	36.0	34.6	47	50	43	160	52	60	48	164	
			428A	50.0	48.1	64	70	59	160	69	70	63	164	
			453A	67.0	64.5	85	90	78	160	90	90	82	164	
			—	—	—	28	30	28	161	31	40	32	165	
	HIGH	5	425A	18.0	17.3	28	30	28	161	33	40	32	165	
			427A	36.0	34.6	49	50	45	161	54	60	49	165	
			428A	50.0	48.1	66	70	61	161	71	80	65	165	
			453A	67.0	64.5	87	90	79	161	92	100	84	165	

Electrical data (cont)

RAV180 MCA MOCP ELECTRICAL DATA (cont)

RAV UNIT SIZE	NOM. V-Ph-Hz	IFM TYPE	STD SCCR kA	ELECTRIC HEATER			w/ POWERED CONVENIENCE OUTLET										
				CRHEATER ****00	NOM (kW)	FLA	NO POWER EXHAUST				w/ POWER EXHAUST (powered from unit)						
							MCA	FUSE OR HACR BRKR	DISCONNECT SIZE		MCA	FUSE OR HACR BRKR	DISCONNECT SIZE				
									FLA	LRA			FLA	LRA			
RAV180	208/230-3-60	STD/MED	5	—	—	—	72	80	74	403	76	100	79	407			
				412A	12.0/16.0	33.4/38.5	72/72	80/80	74/74	403/403	76/76	100/100	79/79	407/407			
				414A	18.8/25.0	52.1/60.1	81/91	90/100	74/83	403/403	86/96	100/100	79/88	407/407			
				415A	24.0/32.0	66.7/77.0	99/112	100/125	91/103	403/403	104/117	110/125	95/107	407/407			
				416A	31.8/42.4	88.4/102.0	126/143	150/150	116/131	403/403	131/148	150/150	120/136	407/407			
				417A	37.6/50.0	104.2/120.3	146/166	150/175	134/152	403/403	151/171	175/175	138/157	407/407			
		451A	50.3/67.0	139.7/161.2	190/217	200/225	175/200	403/403	195/222	200/225	179/204	407/407					
		HIGH	5	—	—	—	77	100	80	410	81	100	85	414			
				412A	12.0/16.0	33.4/38.5	77/77	100/100	80/80	410/410	81/81	100/100	85/85	414/414			
				414A	18.8/25.0	52.1/60.1	87/97	100/100	80/89	410/410	92/102	100/110	85/93	414/414			
				415A	24.0/32.0	66.7/77.0	106/118	110/125	97/109	410/410	110/123	110/125	101/113	414/414			
				416A	31.8/42.4	88.4/102.0	133/150	150/150	122/137	410/410	137/154	150/175	126/142	414/414			
	417A			37.6/50.0	104.2/120.3	152/173	175/175	140/158	410/410	157/177	175/200	144/163	414/414				
	460-3-60	STD/MED	5	—	—	—	35	45	36	211	37	50	38	213			
				420A	15.0	18.0	35	45	36	211	37	50	38	213			
				421A	25.0	30.1	45	45	41	211	47	50	43	213			
				422A	33.0	39.7	57	60	52	211	59	60	54	213			
				423A	41.7	50.2	70	70	64	211	73	80	66	213			
				424A	50.0	60.1	83	90	76	211	85	90	78	213			
		HIGH	5	—	—	—	37	50	38	212	39	50	40	214			
				420A	15.0	18.0	37	50	38	212	39	50	40	214			
				421A	25.0	30.1	48	50	44	212	50	50	46	214			
				422A	33.0	39.7	60	60	55	212	62	70	57	214			
				423A	41.7	50.2	73	80	67	212	75	80	69	214			
				424A	50.0	60.1	85	90	78	212	88	90	80	214			
				452A	67.0	80.6	111	125	102	212	113	125	104	214			
				575-3-60	STD/MED	5	—	—	—	28	35	28	162	31	40	32	166
							425A	18.0	17.3	28	35	28	162	33	40	32	166
427A							36.0	34.6	50	50	45	162	54	60	50	166	
428A	50.0	48.1	66				70	61	162	71	80	65	166				
453A	67.0	64.5	87				90	80	162	92	100	84	166				
HIGH	5	—	—				—	29	40	30	163	33	40	34	167		
		425A	18.0	17.3	30	40	30	163	35	40	34	167					
		427A	36.0	34.6	52	60	47	163	56	60	51	167					
		428A	50.0	48.1	68	70	63	163	73	80	67	167					
		453A	67.0	64.5	89	90	81	163	94	100	86	167					

Electrical data (cont)

RAV090 ELECTRIC HEAT DATA — WITHOUT NON-FUSED DISCONNECT

RAV UNIT SIZE	NOM. V-Ph-Hz	IFM TYPE	ELECTRIC HEATER PART NUMBER	NOM (kW)	STD SCCR kA	APPLICATION (kW)	APPLICATION OUTPUT (MBH)	SINGLE POINT OR JUNCTION KIT PART NUMBER CRSINGLEXXXA00					
								NO C.O. OR UNPOWERED C.O.		w/PWRD C.O.			
								NO P.E.	w/P.E. (pwrd fr/unit)	NO P.E.	w/P.E. (pwrd fr/unit)		
RAV090	208/230-3-60	STD/ MED	CRHEATER411A00	10.4	5.0	7.8/9.6	26.7/32.6	042	042	042	042		
			CRHEATER412A00	16.0	5.0	12.0/14.7	41.0/50.1	042	043	043	043		
			CRHEATER414A00	25.0	5.0	18.8/23.0	64.1/78.3	043	043	043	043		
			CRHEATER415A00	32.0	5.0	24.0/29.4	82.0/100.3	043	043	043	043		
			CRHEATER416A00	42.4	5.0	31.8/38.9	108.7/132.9	045	045	045	045		
		HIGH	CRHEATER411A00	10.4	5.0	7.8/9.6	26.7/32.6	042	042	042	042		
			CRHEATER412A00	16.0	5.0	12.0/14.7	41.0/50.1	042	043	043	043		
			CRHEATER414A00	25.0	5.0	18.8/23.0	64.1/78.3	043	043	043	043		
			CRHEATER415A00	32.0	5.0	24.0/29.4	82.0/100.3	043	043	043	043		
			CRHEATER416A00	42.4	5.0	31.8/38.9	108.7/132.9	045	045	045	045		
			460-3-60	STD/ MED	CRHEATER420A00	15.0	5.0	13.8	47.0	042	042	042	042
					CRHEATER421A00	25.0	5.0	23.0	78.3	042	042	042	042
	CRHEATER422A00	33.0			5.0	30.3	103.4	042	042	042	042		
	CRHEATER423A00	41.7			5.0	38.3	130.7	044	044	044	044		
	HIGH	CRHEATER420A00		15.0	5.0	13.8	47.0	042	042	042	042		
		CRHEATER421A00		25.0	5.0	23.0	78.3	042	042	042	042		
		CRHEATER422A00		33.0	5.0	30.3	103.4	042	042	042	042		
		CRHEATER423A00		41.7	5.0	38.3	130.7	044	044	044	044		
		575-3-60		STD/ MED	CRHEATER425A00	18.0	5.0	16.5	56.4	042	042	042	042
					CRHEATER427A00	36.0	5.0	33.1	112.8	042	042	042	042
	HIGH		CRHEATER425A00	18.0	5.0	16.5	56.4	042	042	042	042		
			CRHEATER427A00	36.0	5.0	33.1	112.8	042	042	042	042		

Electrical data (cont)

RAV090 ELECTRIC HEAT DATA — WITH NON-FUSED DISCONNECT

RAV UNIT SIZE	NOM. V-Ph-Hz	IFM TYPE	ELECTRIC HEATER PART NUMBER	NOM (kW)	STD SCCR kA	APPLICATION (kW)	APPLICATION OUTPUT (MBH)	SINGLE POINT OR JUNCTION KIT PART NUMBER CRSINGLEXXXA00					
								NO C.O. OR UNPOWERED C.O.		w/PWRD C.O.			
								NO P.E.	w/P.E. (pwrd fr/unit)	NO P.E.	w/P.E. (pwrd fr/unit)		
RAV090	208/230-3-60	STD/ MED	CRHEATER411A00	10.4	5.0	7.8/9.6	26.7/32.6	042	042	042	042		
			CRHEATER412A00	16.0	5.0	12.0/14.7	41.0/50.1	042	043	043	043		
			CRHEATER414A00	25.0	5.0	18.8/23.0	64.1/78.3	043	043	043	043		
			CRHEATER415A00	32.0	5.0	24.0/29.4	82.0/100.3	043	043	043	043		
			CRHEATER416A00	42.4	5.0	31.8/38.9	108.7/132.9	045	045	045	045		
		HIGH	CRHEATER411A00	10.4	5.0	7.8/9.6	26.7/32.6	042	042	042	042		
			CRHEATER412A00	16.0	5.0	12.0/14.7	41.0/50.1	042	043	043	043		
			CRHEATER414A00	25.0	5.0	18.8/23.0	64.1/78.3	043	043	043	043		
			CRHEATER415A00	32.0	5.0	24.0/29.4	82.0/100.3	043	043	043	043		
			CRHEATER416A00	42.4	5.0	31.8/38.9	108.7/132.9	045	045	045	045		
			460-3-60	STD/ MED	CRHEATER420A00	15.0	5.0	13.8	47.0	042	042	042	042
					CRHEATER421A00	25.0	5.0	23.0	78.3	042	042	042	042
	CRHEATER422A00	33.0			5.0	30.3	103.4	042	042	042	042		
	CRHEATER423A00	41.7			5.0	38.3	130.7	044	044	044	044		
	HIGH	CRHEATER420A00		15.0	5.0	13.8	47.0	042	042	042	042		
		CRHEATER421A00		25.0	5.0	23.0	78.3	042	042	042	042		
		CRHEATER422A00		33.0	5.0	30.3	103.4	042	042	042	042		
		CRHEATER423A00		41.7	5.0	38.3	130.7	044	044	044	044		
		575-3-60		STD/ MED	CRHEATER425A00	18.0	5.0	16.5	56.4	042	042	042	042
					CRHEATER427A00	36.0	5.0	33.1	112.8	042	042	042	042
				HIGH	CRHEATER425A00	18.0	5.0	16.5	56.4	042	042	042	042
					CRHEATER427A00	36.0	5.0	33.1	112.8	042	042	042	042

Electrical data (cont)

RAV102 ELECTRIC HEAT DATA — WITHOUT NON-FUSED DISCONNECT

RAV UNIT SIZE	NOM. V-Ph-Hz	IFM TYPE	ELECTRIC HEATER PART NUMBER	NOM (kW)	STD SCCR kA	APPLICATION (kW)	APPLICATION OUTPUT (MBH)	SINGLE POINT OR JUNCTION KIT PART NUMBER CRSINGLEXXXA00				
								NO C.O. OR UNPOWERED C.O.		w/PWRD C.O.		
								NO P.E.	w/P.E. (pwrd fr/unit)	NO P.E.	w/P.E. (pwrd fr/unit)	
RAV102	208/230-3-60	STD/MED	CRHEATER411A00	10.4	5.0	7.8/9.6	26.7/32.6	047	047	047	047	
			CRHEATER412A00	16.0	5.0	12.0/14.7	41.0/50.1	047	049	049	049	
			CRHEATER414A00	25.0	5.0	18.8/23.0	64.1/78.3	049	049	049	049	
			CRHEATER415A00	32.0	5.0	24.0/29.4	82.0/100.3	049	049	049	049	
			CRHEATER416A00	42.4	5.0	31.8/38.9	108.7/132.9	051	051	051	051	
		HIGH	CRHEATER411A00	10.4	5.0	7.8/9.6	26.7/32.6	047	047	047	047	
			CRHEATER412A00	16.0	5.0	12.0/14.7	41.0/50.1	047	049	049	049	
			CRHEATER414A00	25.0	5.0	18.8/23.0	64.1/78.3	049	049	049	049	
			CRHEATER415A00	32.0	5.0	24.0/29.4	82.0/100.3	049	049	049	049	
			CRHEATER416A00	42.4	5.0	31.8/38.9	108.7/132.9	051	051	051	051	
		460-3-60	STD/MED	CRHEATER420A00	15.0	5.0	13.8	47.0	047	047	047	047
				CRHEATER421A00	25.0	5.0	23.0	78.3	047	047	047	047
	CRHEATER422A00			33.0	5.0	30.3	103.4	047	047	047	047	
	CRHEATER423A00			41.7	5.0	38.3	130.7	050	050	050	050	
	HIGH		CRHEATER420A00	15.0	5.0	13.8	47.0	047	047	047	047	
			CRHEATER421A00	25.0	5.0	23.0	78.3	047	047	047	047	
			CRHEATER422A00	33.0	5.0	30.3	103.4	047	047	047	047	
			CRHEATER423A00	41.7	5.0	38.3	130.7	050	050	050	050	
	575-3-60		STD/MED	CRHEATER425A00	18.0	5.0	16.5	56.4	047	047	047	047
				CRHEATER427A00	36.0	5.0	33.1	112.8	047	047	047	047
			HIGH	CRHEATER425A00	18.0	5.0	16.5	56.4	047	047	047	047
				CRHEATER427A00	36.0	5.0	33.1	112.8	047	047	047	047

Electrical data (cont)

RAV102 ELECTRIC HEAT DATA — WITH NON-FUSED DISCONNECT

RAV UNIT SIZE	NOM. V-Ph-Hz	IFM TYPE	ELECTRIC HEATER PART NUMBER	NOM (kW)	STD SCCR kA	APPLICATION (kW)	APPLICATION OUTPUT (MBH)	SINGLE POINT OR JUNCTION KIT PART NUMBER CRSINGLEXXXA00					
								NO C.O. OR UNPOWERED C.O.		w/PWRD C.O.			
								NO P.E.	w/P.E. (pwrd fr/unit)	NO P.E.	w/P.E. (pwrd fr/unit)		
RAV102	208/230-3-60	STD/MED	CRHEATER411A00	10.4	5.0	7.8/9.6	26.7/32.6	047	047	047	047		
			CRHEATER412A00	16.0	5.0	12.0/14.7	41.0/50.1	047	049	049	049		
			CRHEATER414A00	25.0	5.0	18.8/23.0	64.1/78.3	049	049	049	049		
			CRHEATER415A00	32.0	5.0	24.0/29.4	82.0/100.3	049	049	049	049		
			CRHEATER416A00	42.4	5.0	31.8/38.9	108.7/132.9	051	051	051	051		
		HIGH	CRHEATER411A00	10.4	5.0	7.8/9.6	26.7/32.6	047	047	047	047		
			CRHEATER412A00	16.0	5.0	12.0/14.7	41.0/50.1	047	049	049	049		
			CRHEATER414A00	25.0	5.0	18.8/23.0	64.1/78.3	049	049	049	049		
			CRHEATER415A00	32.0	5.0	24.0/29.4	82.0/100.3	049	049	049	049		
			CRHEATER416A00	42.4	5.0	31.8/38.9	108.7/132.9	051	051	051	051		
			460-3-60	STD/MED	CRHEATER420A00	15.0	5.0	13.8	47.0	047	047	047	047
					CRHEATER421A00	25.0	5.0	23.0	78.3	047	047	047	047
	CRHEATER422A00	33.0			5.0	30.3	103.4	047	047	047	047		
	CRHEATER423A00	41.7			5.0	38.3	130.7	050	050	050	050		
	HIGH	CRHEATER420A00		15.0	5.0	13.8	47.0	047	047	047	047		
		CRHEATER421A00		25.0	5.0	23.0	78.3	047	047	047	047		
		CRHEATER422A00		33.0	5.0	30.3	103.4	047	047	047	047		
		CRHEATER423A00		41.7	5.0	38.3	130.7	050	050	050	050		
		575-3-60		STD/MED	CRHEATER425A00	18.0	5.0	16.5	56.4	047	047	047	047
					CRHEATER427A00	36.0	5.0	33.1	112.8	047	047	047	047
	HIGH		CRHEATER425A00	18.0	5.0	16.5	56.4	047	047	047	047		
		CRHEATER427A00	36.0	5.0	33.1	112.8	047	047	047	047			

Electrical data (cont)

RAV120 ELECTRIC HEAT DATA — WITHOUT NON-FUSED DISCONNECT

RAV UNIT SIZE	NOM. V-Ph-Hz	IFM TYPE	ELECTRIC HEATER PART NUMBER	NOM (kW)	STD SCCR kA	APPLICATION (kW)	APPLICATION OUTPUT (MBH)	SINGLE POINT OR JUNCTION KIT PART NUMBER CRSINGLEXXXXA00				
								NO C.O. OR UNPOWERED C.O.		w/PWRD C.O.		
								NO P.E.	w/P.E. (pwrd fr/unit)	NO P.E.	w/P.E. (pwrd fr/unit)	
RAV120	208/230-3-60	STD/ MED	CRHEATER411A00	10.4	5.0	7.8/9.6	26.7/32.6	047	047	047	047	
			CRHEATER412A00	16.0	5.0	12.0/14.7	41.0/50.1	047	049	049	049	
			CRHEATER415A00	32.0	5.0	24.0/29.4	82.0/100.3	049	049	049	049	
			CRHEATER416A00	42.4	5.0	31.8/38.9	108.7/132.9	051	051	051	051	
			CRHEATER417A00	50.0	5.0	37.6/45.9	128.1/156.7	051	051	051	051	
		HIGH	CRHEATER411A00	10.4	5.0	7.8/9.6	26.7/32.6	047	047	047	049	
			CRHEATER412A00	16.0	5.0	12.0/14.7	41.0/50.1	049	049	049	049	
			CRHEATER415A00	32.0	5.0	24.0/29.4	82.0/100.3	049	049	049	049	
			CRHEATER416A00	42.4	5.0	31.8/38.9	108.7/132.9	051	051	051	051	
			CRHEATER417A00	50.0	5.0	37.6/45.9	128.1/156.7	051	051	051	051	
			CRHEATER420A00	15.0	5.0	13.8	47.0	047	047	047	047	
			CRHEATER422A00	33.0	5.0	30.3	103.4	047	047	047	047	
	460-3-60	STD/ MED	CRHEATER423A00	41.7	5.0	38.3	130.7	050	050	050	050	
			CRHEATER424A00	50.0	5.0	45.9	156.7	050	050	050	050	
			HIGH	CRHEATER420A00	15.0	5.0	13.8	47.0	047	047	047	047
				CRHEATER422A00	33.0	5.0	30.3	103.4	047	047	047	050
		CRHEATER423A00		41.7	5.0	38.3	130.7	050	050	050	050	
		CRHEATER424A00	50.0	5.0	45.9	156.7	050	050	050	050		
	575-3-60	STD/ MED	CRHEATER425A00	18.0	5.0	16.5	56.4	047	047	047	047	
			CRHEATER427A00	36.0	5.0	33.1	112.8	047	047	047	047	
			CRHEATER428A00	50.0	5.0	45.9	156.7	050	050	050	050	
		HIGH	CRHEATER425A00	18.0	5.0	16.5	56.4	047	047	047	047	
			CRHEATER427A00	36.0	5.0	33.1	112.8	047	047	047	047	
			CRHEATER428A00	50.0	5.0	45.9	156.7	050	050	050	050	

Electrical data (cont)

RAV120 ELECTRIC HEAT DATA — WITH NON-FUSED DISCONNECT

RAV UNIT SIZE	NOM. V-Ph-Hz	IFM TYPE	ELECTRIC HEATER PART NUMBER	NOM (kW)	STD SCCR kA	APPLICATION (kW)	APPLICATION OUTPUT (MBH)	SINGLE POINT OR JUNCTION KIT PART NUMBER CRSINGLEXXXA00					
								NO C.O. OR UNPOWERED C.O.		w/PWRD C.O.			
								NO P.E.	w/P.E. (pwrd fr/unit)	NO P.E.	w/P.E. (pwrd fr/unit)		
RAV120	208/230-3-60	STD/ MED	CRHEATER411A00	10.4	5.0	7.8/9.6	26.7/32.6	047	047	047	047		
			CRHEATER412A00	16.0	5.0	12.0/14.7	41.0/50.1	047	049	049	049		
			CRHEATER415A00	32.0	5.0	24.0/29.4	82.0/100.3	049	049	049	049		
			CRHEATER416A00	42.4	5.0	31.8/38.9	108.7/132.9	051	051	051	051		
			CRHEATER417A00	50.0	5.0	37.6/45.9	128.1/156.7	051	051	051	051		
		HIGH	CRHEATER411A00	10.4	5.0	7.8/9.6	26.7/32.6	047	047	047	049		
			CRHEATER412A00	16.0	5.0	12.0/14.7	41.0/50.1	049	049	049	049		
			CRHEATER415A00	32.0	5.0	24.0/29.4	82.0/100.3	049	049	049	049		
			CRHEATER416A00	42.4	5.0	31.8/38.9	108.7/132.9	051	051	051	051		
			CRHEATER417A00	50.0	5.0	37.6/45.9	128.1/156.7	051	051	051	051		
			460-3-60	STD/ MED	CRHEATER420A00	15.0	5.0	13.8	47.0	047	047	047	047
					CRHEATER422A00	33.0	5.0	30.3	103.4	047	047	047	047
	CRHEATER423A00	41.7			5.0	38.3	130.7	050	050	050	050		
	CRHEATER424A00	50.0			5.0	45.9	156.7	050	050	050	050		
	HIGH	CRHEATER420A00		15.0	5.0	13.8	47.0	047	047	047	047		
		CRHEATER422A00	33.0	5.0	30.3	103.4	047	047	047	050			
		CRHEATER423A00	41.7	5.0	38.3	130.7	050	050	050	050			
		CRHEATER424A00	50.0	5.0	45.9	156.7	050	050	050	050			
		575-3-60	STD/ MED	CRHEATER425A00	18.0	5.0	16.5	56.4	047	047	047	047	
	CRHEATER427A00			36.0	5.0	33.1	112.8	047	047	047	047		
	CRHEATER428A00			50.0	5.0	45.9	156.7	050	050	050	050		
	HIGH		CRHEATER425A00	18.0	5.0	16.5	56.4	047	047	047	047		
			CRHEATER427A00	36.0	5.0	33.1	112.8	047	047	047	047		
			CRHEATER428A00	50.0	5.0	45.9	156.7	050	050	050	050		

Electrical data (cont)

RAV150 ELECTRIC HEAT DATA — WITHOUT NON-FUSED DISCONNECT

RAV UNIT SIZE	NOM. V-Ph-Hz	IFM TYPE	ELECTRIC HEATER PART NUMBER	NOM (kW)	STD SCCR kA	APPLICATION (kW)	APPLICATION OUTPUT (MBH)	SINGLE POINT OR JUNCTION KIT PART NUMBER CRSINGLEXXXXA00			
								NO C.O. OR UNPOWERED C.O.		w/PWRD C.O.	
								NO P.E.	w/P.E. (pwrd fr/unit)	NO P.E.	w/P.E. (pwrd fr/unit)
RAV150	208/230-3-60	STD/ MED	CRHEATER411A00	10.4	5.0	7.8/9.6	26.7/32.6	049	049	049	049
			CRHEATER412A00	16.0	5.0	12.0/14.7	41.0/50.1	049	049	049	049
			CRHEATER415A00	32.0	5.0	24.0/29.4	82.0/100.3	049	049	049	049
			CRHEATER416A00	42.4	5.0	31.8/38.9	108.7/132.9	051	051	051	051
			CRHEATER417A00	50.0	5.0	37.6/45.9	128.1/156.7	051	051	051	051
		HIGH	CRHEATER411A00	10.4	5.0	7.8/9.6	26.7/32.6	049	049	049	049
			CRHEATER412A00	16.0	5.0	12.0/14.7	41.0/50.1	049	049	049	049
			CRHEATER415A00	32.0	5.0	24.0/29.4	82.0/100.3	049	049	049	049
	460-3-60	STD/ MED	CRHEATER420A00	15.0	5.0	13.8	47.0	047	047	047	047
			CRHEATER422A00	33.0	5.0	30.3	103.4	047	047	047	047
			CRHEATER423A00	41.7	5.0	38.3	130.7	050	050	050	050
			CRHEATER424A00	50.0	5.0	45.9	156.7	050	050	050	050
		HIGH	CRHEATER420A00	15.0	5.0	13.8	47.0	047	047	047	047
			CRHEATER422A00	33.0	5.0	30.3	103.4	047	047	047	050
			CRHEATER423A00	41.7	5.0	38.3	130.7	050	050	050	050
			CRHEATER424A00	50.0	5.0	45.9	156.7	050	050	050	050
	575-3-60	STD/ MED	CRHEATER425A00	18.0	5.0	16.5	56.4	047	047	047	047
			CRHEATER427A00	36.0	5.0	33.1	112.8	047	047	047	047
			CRHEATER428A00	50.0	5.0	45.9	156.7	050	050	050	050
		HIGH	CRHEATER425A00	18.0	5.0	16.5	56.4	047	047	047	047
			CRHEATER427A00	36.0	5.0	33.1	112.8	047	047	047	047
			CRHEATER428A00	50.0	5.0	45.9	156.7	050	050	050	050

Electrical data (cont)

RAV150 ELECTRIC HEAT DATA — WITH NON-FUSED DISCONNECT

RAV UNIT SIZE	NOM. V-Ph-Hz	IFM TYPE	ELECTRIC HEATER PART NUMBER	NOM (kW)	STD SCCR kA	APPLICATION (kW)	APPLICATION OUTPUT (MBH)	SINGLE POINT OR JUNCTION KIT PART NUMBER CRSINGLEXXXA00				
								NO C.O. OR UNPOWERED C.O.		w/PWRD C.O.		
								NO P.E.	w/P.E. (pwrd fr/unit)	NO P.E.	w/P.E. (pwrd fr/unit)	
RAV150	208/230-3-60	STD/ MED	CRHEATER411A00	10.4	5.0	7.8/9.6	26.7/32.6	049	049	049	049	
			CRHEATER412A00	16.0	5.0	12.0/14.7	41.0/50.1	049	049	049	049	
			CRHEATER415A00	32.0	5.0	24.0/29.4	82.0/100.3	049	049	049	049	
			CRHEATER416A00	42.4	5.0	31.8/38.9	108.7/132.9	051	051	051	051	
			CRHEATER417A00	50.0	5.0	37.6/45.9	128.1/156.7	051	051	051	051	
		HIGH	CRHEATER411A00	10.4	5.0	7.8/9.6	26.7/32.6	049	049	049	049	
			CRHEATER412A00	16.0	5.0	12.0/14.7	41.0/50.1	049	049	049	049	
			CRHEATER415A00	32.0	5.0	24.0/29.4	82.0/100.3	049	049	049	049	
			CRHEATER416A00	42.4	5.0	31.8/38.9	108.7/132.9	051	051	051	051	
			CRHEATER417A00	50.0	5.0	37.6/45.9	128.1/156.7	051	051	051	051	
			CRHEATER420A00	15.0	5.0	13.8	47.0	047	047	047	047	
			CRHEATER422A00	33.0	5.0	30.3	103.4	047	047	047	047	
	460-3-60	STD/ MED	CRHEATER423A00	41.7	5.0	38.3	130.7	050	050	050	050	
			CRHEATER424A00	50.0	5.0	45.9	156.7	050	050	050	050	
			HIGH	CRHEATER420A00	15.0	5.0	13.8	47.0	047	047	047	047
				CRHEATER422A00	33.0	5.0	30.3	103.4	047	047	047	050
		CRHEATER423A00		41.7	5.0	38.3	130.7	050	050	050	050	
		CRHEATER424A00	50.0	5.0	45.9	156.7	050	050	050	050		
	575-3-60	STD/ MED	CRHEATER425A00	18.0	5.0	16.5	56.4	047	047	047	047	
			CRHEATER427A00	36.0	5.0	33.1	112.8	047	047	047	047	
			CRHEATER428A00	50.0	5.0	45.9	156.7	050	050	050	050	
			HIGH	CRHEATER425A00	18.0	5.0	16.5	56.4	047	047	047	047
		CRHEATER427A00		36.0	5.0	33.1	112.8	047	047	047	047	
		CRHEATER428A00		50.0	5.0	45.9	156.7	050	050	050	050	
CRHEATER428A00		50.0		5.0	45.9	156.7	050	050	050	050		

Electrical data (cont)

RAV180 ELECTRIC HEAT DATA — WITHOUT NON-FUSED DISCONNECT

RAV UNIT SIZE	NOM. V-Ph-Hz	IFM TYPE	ELECTRIC HEATER PART NUMBER	NOM (kW)	STD SCCR kA	APPLICATION (kW)	APPLICATION OUTPUT (MBH)	SINGLE POINT OR JUNCTION KIT PART NUMBER CRSINGLEXXXXA00			
								NO C.O. OR UNPOWERED C.O.		w/PWRD C.O.	
								NO P.E.	w/P.E. (pwrd fr/unit)	NO P.E.	w/P.E. (pwrd fr/unit)
RAV180	208/230-3-60	STD/MED	CRHEATER412A00	16	5	12.0/14.7	41.0/50.1	049	049	049	049
			CRHEATER414A00	25	5	18.8/23.0	64.1/78.3	049	049	049	049
			CRHEATER415A00	32	5	24.0/29.4	82.0/100.3	049	049	049	049
			CRHEATER416A00	42.4	5	31.8/38.9	108.7/132.9	051	051	051	051
			CRHEATER417A00	50	5	37.6/45.9	128.1/156.7	051	051	051	051
			CRHEATER451A00	67	5	50.3/61.5	171.7/210.0	053	053	053	053
		HIGH	CRHEATER412A00	16	5	12.0/14.7	41.0/50.1	049	049	049	049
			CRHEATER414A00	25	5	18.8/23.0	64.1/78.3	049	049	049	049
			CRHEATER415A00	32	5	24.0/29.4	82.0/100.3	049	049	049	049
			CRHEATER416A00	42.4	5	31.8/38.9	108.7/132.9	051	051	051	051
			CRHEATER417A00	50	5	37.6/45.9	128.1/156.7	051	051	051	051
			CRHEATER451A00	67	5	50.3/61.5	171.7/210.0	053	053	053	053
	460-3-60	STD/MED	CRHEATER420A00	15	5	13.8	47.0	—	—	—	—
			CRHEATER421A00	25	5	23.0	78.3	047	047	047	047
			CRHEATER422A00	33	5	30.3	103.4	047	047	047	047
			CRHEATER423A00	41.7	5	38.3	130.7	050	050	050	050
			CRHEATER424A00	50	5	45.9	156.7	050	050	050	050
			CRHEATER452A00	67	5	61.5	210.0	052	052	052	052
		HIGH	CRHEATER420A00	15	5	13.8	47.0	-	-	-	-
			CRHEATER421A00	25	5	23.0	78.3	047	047	047	047
			CRHEATER422A00	33	5	30.3	103.4	047	047	047	050
			CRHEATER423A00	41.7	5	38.3	130.7	050	050	050	050
			CRHEATER424A00	50	5	45.9	156.7	050	050	050	050
			CRHEATER452A00	67	5	61.5	210.0	052	052	052	052
	575-3-60	STD/MED	CRHEATER425A00	18	5	16.5	56.4	—	—	—	—
			CRHEATER427A00	36	5	33.1	112.8	047	047	047	047
			CRHEATER428A00	50	5	45.9	156.7	050	050	050	050
CRHEATER453A00			67	5	61.5	210.0	052	052	052	052	
HIGH		CRHEATER425A00	18	5	16.5	56.4	—	—	—	—	
		CRHEATER427A00	36	5	33.1	112.8	047	047	047	047	
		CRHEATER428A00	50	5	45.9	156.7	050	050	050	050	
		CRHEATER453A00	67	5	61.5	210.0	052	052	052	052	

Electrical data (cont)

RAV180 ELECTRIC HEAT DATA — WITH NON-FUSED DISCONNECT

RAV UNIT SIZE	NOM. V-Ph-Hz	IFM TYPE	ELECTRIC HEATER PART NUMBER	NOM (kW)	STD SCCR kA	APPLICATION (kW)	APPLICATION OUTPUT (MBH)	SINGLE POINT OR JUNCTION KIT PART NUMBER CRSINGLEXXXA00			
								NO C.O. OR UNPOWERED C.O.		w/PWRD C.O.	
								NO P.E.	w/P.E. (pwrd fr/unit)	NO P.E.	w/P.E. (pwrd fr/unit)
RAV180	208/230-3-60	STD/ MED	CRHEATER412A00	16.0	5.0	12.0/14.7	41.0/50.1	049	049	049	049
			CRHEATER414A00	25.0	5.0	18.8/23.0	64.1/78.3	049	049	049	049
			CRHEATER415A00	32.0	5.0	24.0/29.4	82.0/100.3	049	049	049	049
			CRHEATER416A00	42.4	5.0	31.8/38.9	108.7/132.9	051	051	051	051
			CRHEATER417A00	50.0	5.0	37.6/45.9	128.1/156.7	051	051	051	051
			CRHEATER451A00	67.0	5.0	50.3/61.5	171.7/210.0	053	053	053	053
		HIGH	CRHEATER412A00	16.0	5.0	12.0/14.7	41.0/50.1	049	049	049	049
			CRHEATER414A00	25.0	5.0	18.8/23.0	64.1/78.3	049	049	049	049
			CRHEATER415A00	32.0	5.0	24.0/29.4	82.0/100.3	049	049	049	049
			CRHEATER416A00	42.4	5.0	31.8/38.9	108.7/132.9	051	051	051	051
			CRHEATER417A00	50.0	5.0	37.6/45.9	128.1/156.7	051	051	051	051
			CRHEATER451A00	67.0	5.0	50.3/61.5	171.7/210.0	053	053	053	053
	460-3-60	STD/ MED	CRHEATER420A00	15.0	5.0	13.8	47.0	—	—	—	—
			CRHEATER421A00	25.0	5.0	23.0	78.3	047	047	047	047
			CRHEATER422A00	33.0	5.0	30.3	103.4	047	047	047	047
			CRHEATER423A00	41.7	5.0	38.3	130.7	050	050	050	050
			CRHEATER424A00	50.0	5.0	45.9	156.7	050	050	050	050
			CRHEATER452A00	67.0	5.0	61.5	210.0	052	052	052	052
		HIGH	CRHEATER420A00	15.0	5.0	13.8	47.0	—	—	—	—
			CRHEATER421A00	25.0	5.0	23.0	78.3	047	047	047	047
			CRHEATER422A00	33.0	5.0	30.3	103.4	047	047	047	050
			CRHEATER423A00	41.7	5.0	38.3	130.7	050	050	050	050
			CRHEATER424A00	50.0	5.0	45.9	156.7	050	050	050	050
			CRHEATER452A00	67.0	5.0	61.5	210.0	052	052	052	052
	575-3-60	STD/ MED	CRHEATER425A00	18.0	5.0	16.5	56.4	—	—	—	—
			CRHEATER427A00	36.0	5.0	33.1	112.8	047	047	047	047
			CRHEATER428A00	50.0	5.0	45.9	156.7	050	050	050	050
CRHEATER453A00			67.0	5.0	61.5	210.0	052	052	052	052	
HIGH		CRHEATER425A00	18.0	5.0	16.5	56.4	—	—	—	—	
		CRHEATER427A00	36.0	5.0	33.1	112.8	047	047	047	047	
		CRHEATER428A00	50.0	5.0	45.9	156.7	050	050	050	050	
		CRHEATER453A00	67.0	5.0	61.5	210.0	052	052	052	052	

TYPICAL CONTROL WIRING DIAGRAM — RGV090-120 208-230/460/575-3-60 UNIT WITH ELECTROMECHANICAL CONTROL AND W7220 ECONOMIZER

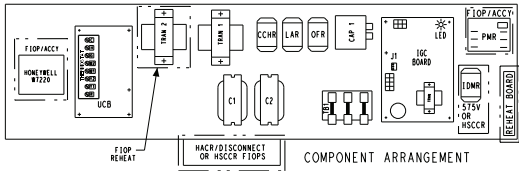

- NOTES:
1. UCB SCHEMATIC LAYOUT DOES NOT MATCH ACTUAL TERMINAL BOARD LAYOUT.
 2. TERMINAL BOARD JUMPERS 1, 2 AND 3 ARE CUT FOR REHEAT UNITS ONLY.
 3. REMOVE DESIGNATED JUMPERS ON UCB WHEN ADDING SMOKE DETECTORS, OCCUPANCY AND REMOTE SHUTDOWN.
 4. USE ABC AS COARSE AND POT AS FINE ADJUSTMENTS FOR SETTING HIGH FAN SPEED. LOW SPEED IS AN OFFSET BASED ON DIP SWITCHES.
 5. 2-PIN LOW SPEED DIP SWITCH POSITIONS ARE FACTORY SET AS SHOWN. EXCEPTION ON 11 & 5 TON UNITS, THESE ARE SET TO "ON-OFF".
 6. HANDBRAKE AND COUPLER SET TO "MAN". JUMPER PIN ON TOP 2-PINS AS SHOWN.
 7. THE * WIRE COLOR IS FOR DIFFERENTIATION WITHIN THIS SCHEMATIC.
 8. TRANSFORMER IS DEDICATED BASED ON UNIT VOLTAGE. TAPS ONLY SHOWN TO SIMPLIFY SCHEMATIC. 208/230V UNIT TRAIN IS WIRE FOR 230V UNIT. IF UNIT IS TO BE RUN WITH 208V POWER SUPPLY DISCONNECT BLK WIRE FROM 230V TAP AND CONNECT TO 208V TAP.
 9. IGC P3 SETTING: 30 SEC.

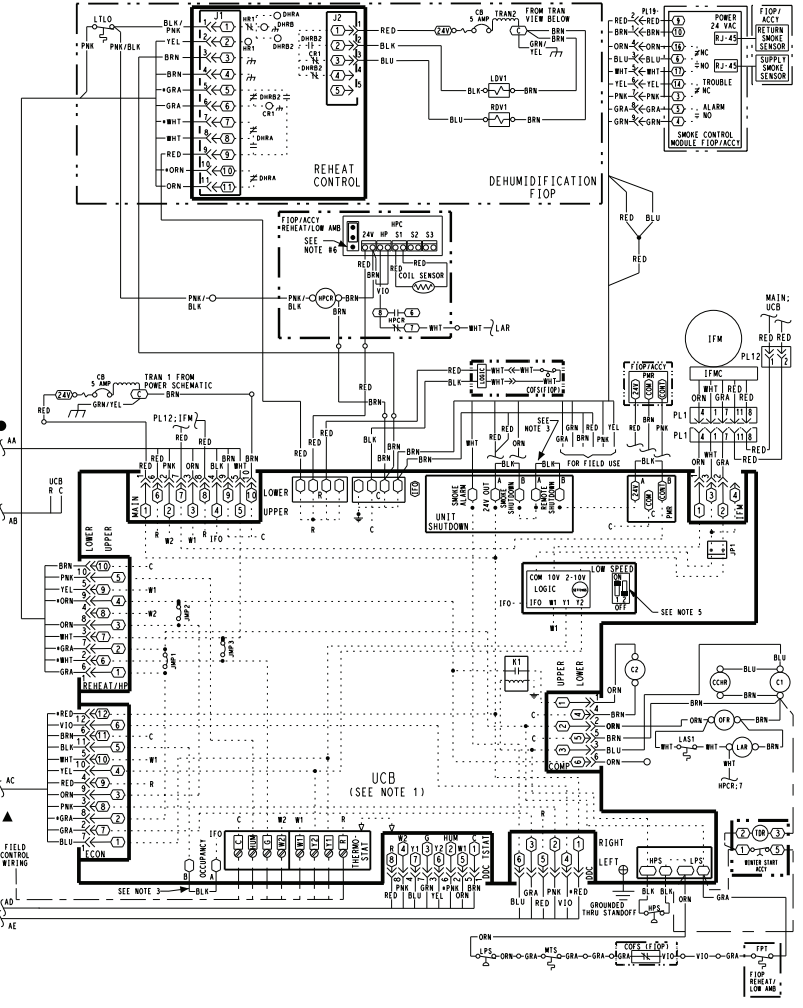
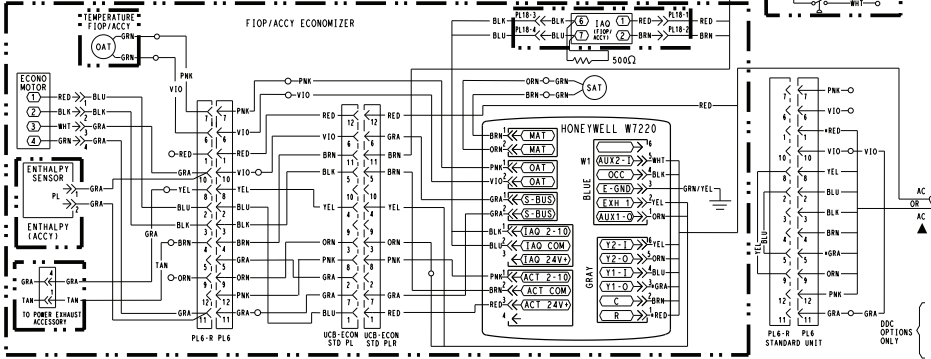
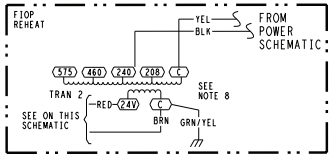

YAC CONTROL 230/460/575V T1 7.5-10 TON, T2 6-8.5 TON

48T1M05713 | E

Typical wiring diagrams (cont)

TYPICAL POWER WIRING DIAGRAM — RGV090-120 208-230/460-3-60 UNIT WITH ELECTROMECHANICAL CONTROLLERS

YAC POWER 230/460V
 T1 7.5-10 TON
 T2 6-8.5 TON

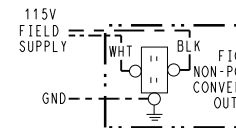
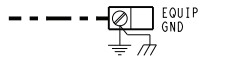
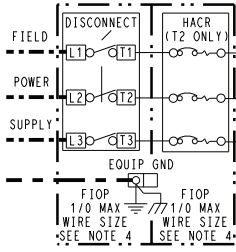

LEGEND

- (X) MARKED WIRE
- (I) TERMINAL (MARKED)
- TERMINAL (UNMARKED)
- TERMINAL BLOCK
- SPLICE
- ◊ SPLICE (MARKED)
- FACTORY WIRING
- - - FIELD CONTROL WIRING
- - - - FIELD POWER WIRING
- - - - - CIRCUIT BOARD TRACE
- · - · - ACCESSORY OR OPTIONAL WIRING
- · — · — TO INDICATE COMMON POTENTIAL ONLY; NOT TO REPRESENT WIRING

NOTES:

1. IF ANY OF THE ORIGINAL WIRE FURNISHED MUST BE REPLACED, IT MUST BE REPLACED WITH TYPE 90 C WIRE OR ITS EQUIVALENT.
2. COMPRESSOR AND FAN MOTORS ARE THERMALLY PROTECTED. THREE PHASE MOTORS ARE PROTECTED AGAINST PRIMARY SINGLE PHASING CONDITIONS.
3. USE COPPER CONDUCTOR ONLY.
4. YELLOW WIRE CONNECTED TO RESPECTIVE VOLTAGE TAP.
5. TRANSFORMER IS DEDICATED BASED ON UNIT VOLTAGE. TAPS ONLY SHOWN TO SIMPLIFY SCHEMATIC. 208/230V UNIT TRAN IS WIRED FOR 230V UNIT. IF UNIT IS TO BE RUN WITH 208V POWER SUPPLY DISCONNECT BLK WIRE FROM 230V TAP AND CONNECT TO 208V TAP.

ACCY	ACCESSORY	HS	HALL EFFECT SENSOR	OFM	OUTDOOR FAN MOTOR
AMB	AMBIENT	I	IGNITOR	OFR	OUTDOOR FAN RELAY
C	CONTACTOR, COMPRESSOR	IAQ	INDOOR AIR QUALITY SENSORS	OL	OVERLOAD
CAP	CAPACITOR	IDM	INDUCED DRAFT MOTOR	PL	PLUG ASSEMBLY
CB	CIRCUIT BREAKER	IFCB	INDOOR FAN CIRCUIT BREAKER	POT	POTENTIOMETER
CCH	CRANKCASE HEATER	IFM	INDOOR FAN MOTOR	PMR	PHASE MONITOR RELAY
CCHR	CRANKCASE HEATER RELAY	IFMC	INDOOR FAN CONTROLLER	POT	QUADRUPLE TERMINAL
CMB	COMBUSTION	IGC	INTEGRATED GAS CONTROL	OT	RETURN AIR RELATIVE HUMIDITY
COFS	CONDENSATE OVERFLOW SWT	JMP	JUMPER	RARH	RETURN AIR TEMP. SENSOR
COMP	COMPRESSOR MOTOR	LA	LOW AMBIENT	RDV	REHEAT DISCHARGE VALVE
DDC	DIRECT DIGITAL CONTROL	LAR	LOW AMBIENT RELAY	RS	ROLLOUT SWITCH
ERV	ENERGY RECOVERY VENTILATOR	LDV	LIQUID DIVERTER VALVE	SAT	SUPPLY AIR TEMP. SENSOR
FIOF	FACTORY INSTALLED OPTION	LPS	LOW PRESSURE SWITCH	SEN	SENSOR
FLS	FAN LIMIT SWITCH	LSM	LIMIT SWITCH (MANUAL RESET)	SPRH	SPACE RELATIVE HUMIDITY
FPT	FREEZE PROTECTION THERMOSTAT	LS	LIMIT SWITCH	SPT	SPACE TEMPERATURE SENSOR
FSD	FIRE SHUT DOWN	LTLO	LOW TEMPERATURE LOCKOUT	SPTO	SPACE TEMPERATURE OFFSET
FS	FLAME SENSOR	MV	VOLTAGE RESTRICTOR	STD	STANDARD
FU	FUSE	MTR	MOTOR	TB	TERMINAL BLOCK
GND	GROUND	MTS	MIXED AIR TEMPERATURE SWITCH	TDR	TIME DELAY RELAY(WINTER START)
GVR	GAS VALVE RELAY	OAO	OUTDOOR AIR QUALITY	TRAN	TRANSFORMER
HPC	HEAD PRESSURE CONTROL	OARH	OUTSIDE AIR RELATIVE HUMIDITY	UCB	UNIT CONTROL BOARD
HPS	HIGH PRESSURE SWITCH	OAT	OUTDOOR AIR TEMP. SENSOR		

48TM005719 E

TYPICAL CONTROL WIRING DIAGRAM — RGV150 208-230/460/575-3-60 UNIT WITH ELECTROMECHANICAL CONTROL AND W7220 ECONOMIZER

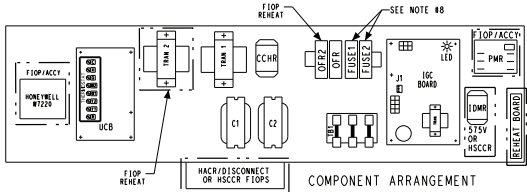

- NOTES:
1. UCB SCHEMATIC LAYOUT DOES NOT MATCH ACTUAL TERMINAL BOARD LAYOUT.
 2. TERMINAL BOARD JUMPERS 1 & 2 AND 3 ARE CUT FOR REHEAT UNITS ONLY.
 3. REMOVE DESIGNATED JUMPERS ON UCB WHEN ADDING SMOKE DETECTIONS, OCCUPANCY AND REMOTE SHUTDOWN.
 4. USE AUC AS COARSE AND POT AS FINE ADJUSTMENTS FOR SETTING HIGH FAN SPEED. LOW SPEED IS AN OFFSET BASED ON DIP SWITCHES.
 5. 2-PIN LOW SPEED DIP SWITCH POSITIONS ARE FACTORY SET AS SHOWN.
 6. HANDSTART AND CUTOFF SET TO "MIN" JUMPER PIN ON TOP 2-PINS AS SHOWN.
 7. THE * WIRE COLOR IS FOR DIFFERENTIATION WITHIN THIS SCHEMATIC.
 8. FUSES FOR 230V ARE LOCATED IN CONTROL BOX. FUSES FOR 460/575V ARE LOCATED BELOW THE CONTROL BOX.
 9. IGC P3 SETTING: 30 SEC.
 10. TRANSFORMER IS DESIGNATED BASED ON UNIT VOLTAGE. TAPS ONLY SHOWN TO SIMPLIFY SCHEMATIC. 208/230V UNIT TRN IS WIRED FOR 230V UNIT. IF UNIT IS TO BE RUN WITH 208V POWER SUPPLY DISCONNECT BLK WIRE FROM 230V TAP AND CONNECT TO 208V TAP.

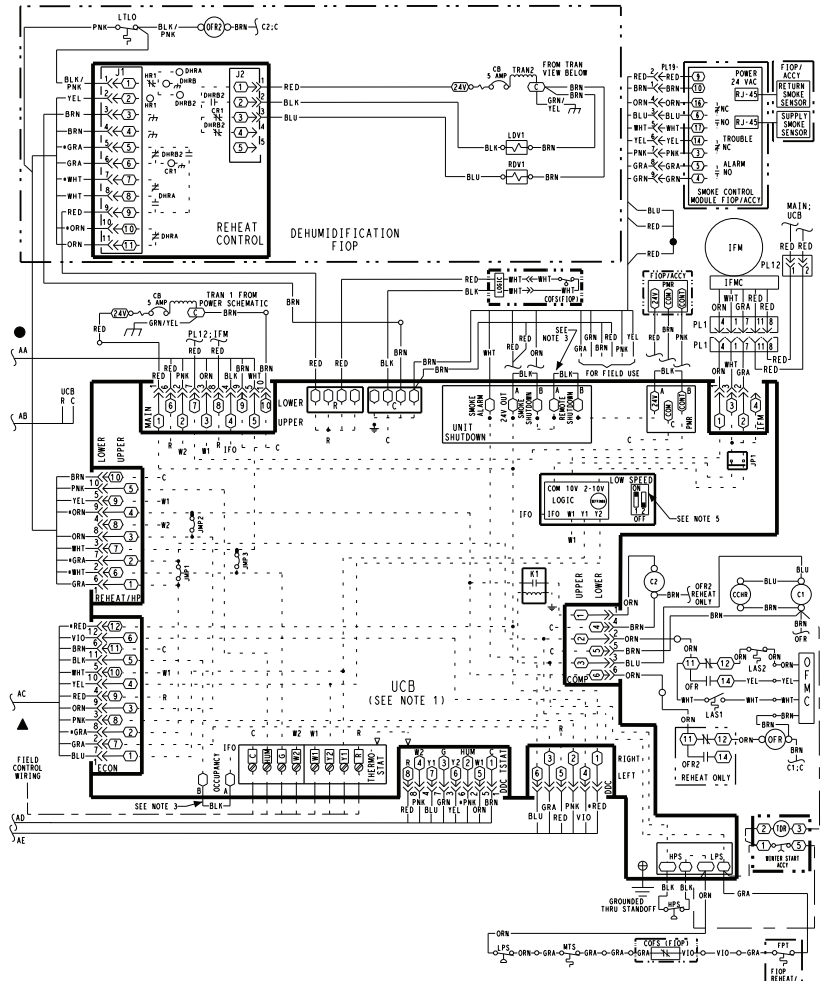
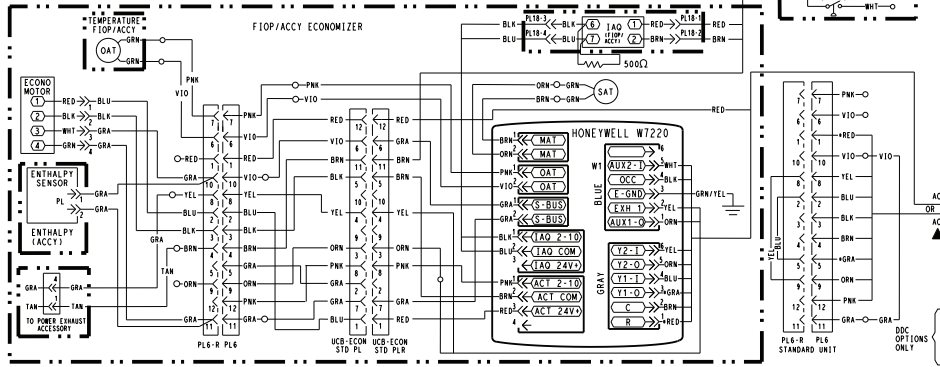
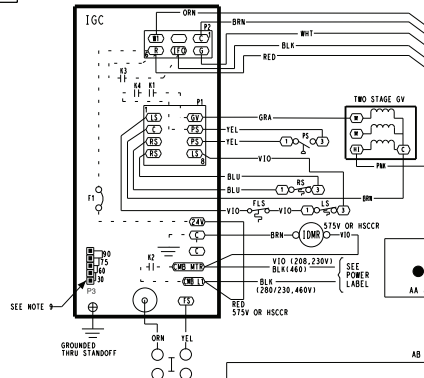
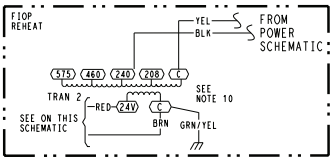

YAC CONTROL 230/460/575V T1 12.5 TON, T2 10 TON

Typical wiring diagrams (cont)

TYPICAL POWER WIRING DIAGRAM — RGV150 208-230/3/60 UNIT WITH ELECTROMECHANICAL CONTROLLER

YAC POWER 230V
T1 12.5 TON
T2 10 TON

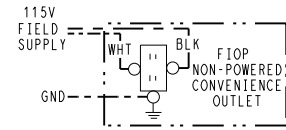
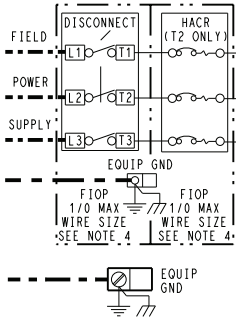

LEGEND

- (X) MARKED WIRE
- (I) TERMINAL (MARKED)
- TERMINAL (UNMARKED)
- ⊗ TERMINAL BLOCK
- SPLICE
- ⊕ SPLICE (MARKED)
- FACTORY WIRING
- - - FIELD CONTROL WIRING
- - - FIELD POWER WIRING
- - - CIRCUIT BOARD TRACE
- - - ACCESSORY OR OPTIONAL WIRING
- TO INDICATE COMMON POTENTIAL ONLY; NOT TO REPRESENT WIRING

NOTES:

1. IF ANY OF THE ORIGINAL WIRE FURNISHED MUST BE REPLACED, IT MUST BE REPLACED WITH TYPE 90 C WIRE OR ITS EQUIVALENT.
2. COMPRESSOR AND FAN MOTORS ARE THERMALLY PROTECTED. THREE PHASE MOTORS ARE PROTECTED AGAINST PRIMARY SINGLE PHASING CONDITIONS.
3. 208/230V UNIT TRAN IS WIRED FOR 230V UNIT. IF UNIT IS TO BE RUN WITH 208V POWER SUPPLY DISCONNECT BLK WIRE FROM 240V TAP AND CONNECT TO 208V TAP
4. USE COPPER CONDUCTOR ONLY.

ACCY	ACCESSORY	HS	HALL EFFECT SENSOR
AMB	AMBIENT	I	IGNITOR
C	CONTACTOR, COMPRESSOR	IAQ	INDOOR AIR QUALITY SENSORS
CAP	CAPACITOR	IDM	INDUCED DRAFT MOTOR
CB	CIRCUIT BREAKER	IFCB	INDOOR FAN CIRCUIT BREAKER
CCH	CRANKCASE HEATER	IFM	INDOOR FAN MOTOR
CCHR	CRANKCASE HEATER RELAY	IFMC	INDOOR FAN CONTROLLER
CMB	COMBUSTION	IGC	INTEGRATED GAS CONTROL
COFS	CONDENSATE OVERFLOW SWT	JMP	JUMPER
COMP	COMPRESSOR MOTOR	LA	LOW AMBIENT
DDC	DIRECT DIGITAL CONTROL	LAV	LIQUID DIVERTER VALVE
ERV	ENERGY RECOVERY VENTILATOR	LPS	LOW PRESSURE SWITCH
FIOF	FACTORY INSTALLED OPTION	LSM	LIMIT SWITCH (MANUAL RESET)
FLS	FAN LIMIT SWITCH	LS	LIMIT SWITCH
FPT	FREEZE PROTECTION THERMOSTAT	LTLO	LOW TEMPERATURE LOCKOUT
FSD	FIRE SHUT DOWN	MGV	MAIN GAS VALVE
FS	FLAME SENSOR	MOV	VOLTAGE RESTRICTOR
FU	FUSE	MTR	MOTOR
GND	GROUND	MTS	MIXED AIR TEMPERATURE SWITCH
GVR	GAS VALVE RELAY	OAQ	OUTDOOR AIR QUALITY
HPC	HEAD PRESSURE CONTROL	OARH	OUTSIDE AIR RELATIVE HUMIDITY
HPS	HIGH PRESSURE SWITCH	OAT	OUTDOOR AIR TEMP. SENSOR

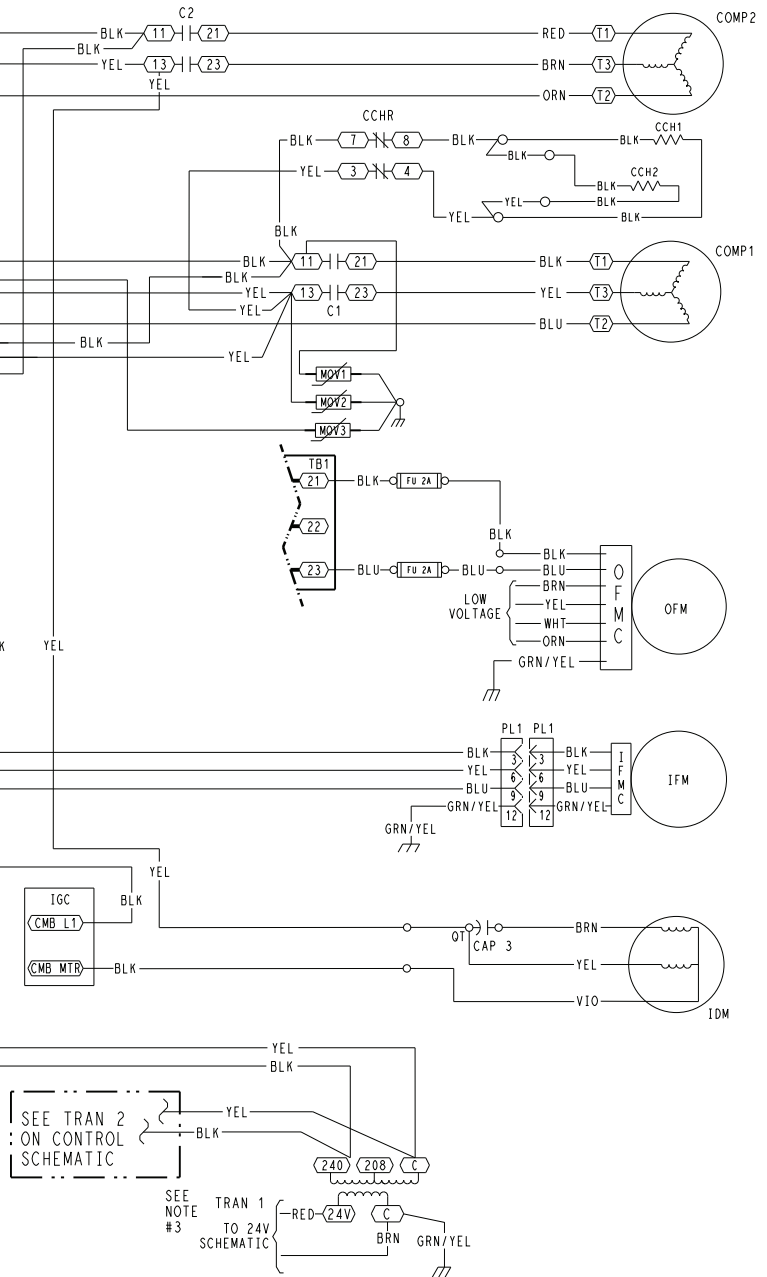

48TM005991 C

**TYPICAL CONTROL WIRING DIAGRAM — RGV180 230/460/575-3-60 UNIT
WITH ELECTROMECHANICAL CONTROLLER**

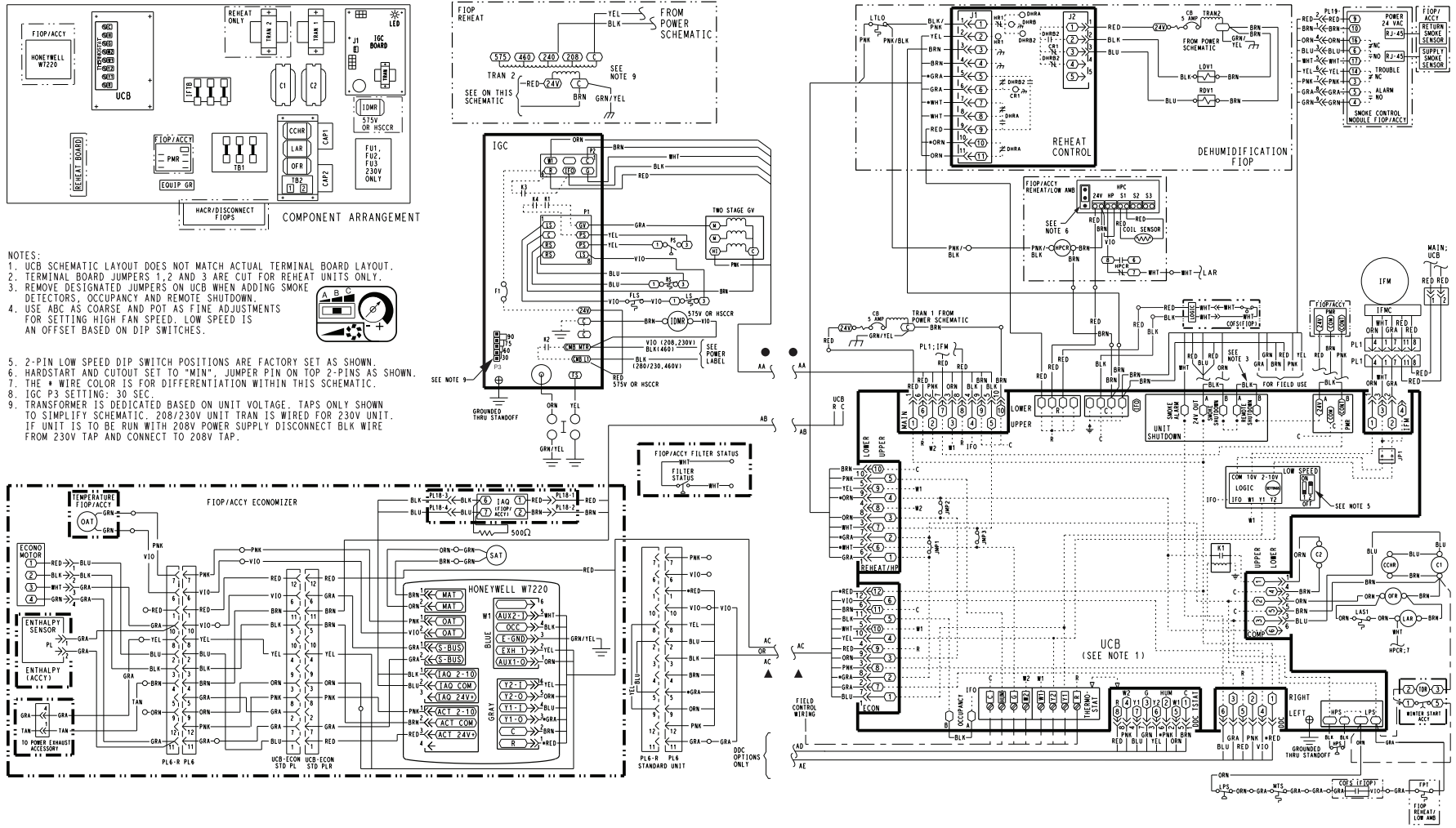

YAC CONTROL 230/460/575V T1 15 TON, T2 12.5 TON
50TM0019111 C

- NOTES:**
1. UCB SCHEMATIC LAYOUT DOES NOT MATCH ACTUAL TERMINAL BOARD LAYOUT.
 2. TERMINAL BOARD JUMPERS 1, 2 AND 3 ARE CUT FOR REHEAT UNITS ONLY.
 3. REMOVE DESIGNATED JUMPERS ON UCB WHEN ADDING SMOKE DETECTORS, OCCUPANCY AND REMOTE SHUTDOWN.
 4. USE ABC AS COARSE AND POT AS FINE ADJUSTMENTS FOR SETTING HIGH FAN SPEED. LOW SPEED IS AN OFFSET BASED ON DIP SWITCHES.
 5. 2-PIN LOW SPEED DIP SWITCH POSITIONS ARE FACTORY SET AS SHOWN.
 6. HARDSTART AND CUTOFF SET TO "MIN", JUMPER PIN ON TOP 2-PINS AS SHOWN.
 7. THE * WIRE COLOR IS FOR DIFFERENTIATION WITHIN THIS SCHEMATIC.
 8. IGC P3 SETTING: 30 SEC.
 9. TRANSFORMER IS DEDICATED BASED ON UNIT VOLTAGE. TAPS ONLY SHOWN TO SIMPLIFY SCHEMATIC. 208/230V UNIT TRAN IS WIRED FOR 230V UNIT. IF UNIT IS TO BE RUN WITH 208V POWER SUPPLY DISCONNECT BLK WIRE FROM 230V TAP AND CONNECT TO 208V TAP.

Typical wiring diagrams (cont)

TYPICAL POWER WIRING DIAGRAM — RGV180 208-230/460-3-60 UNIT WITH ELECTROMECHANICAL CONTROLLERS

YAC POWER 208/230, 460V T1 15 TON

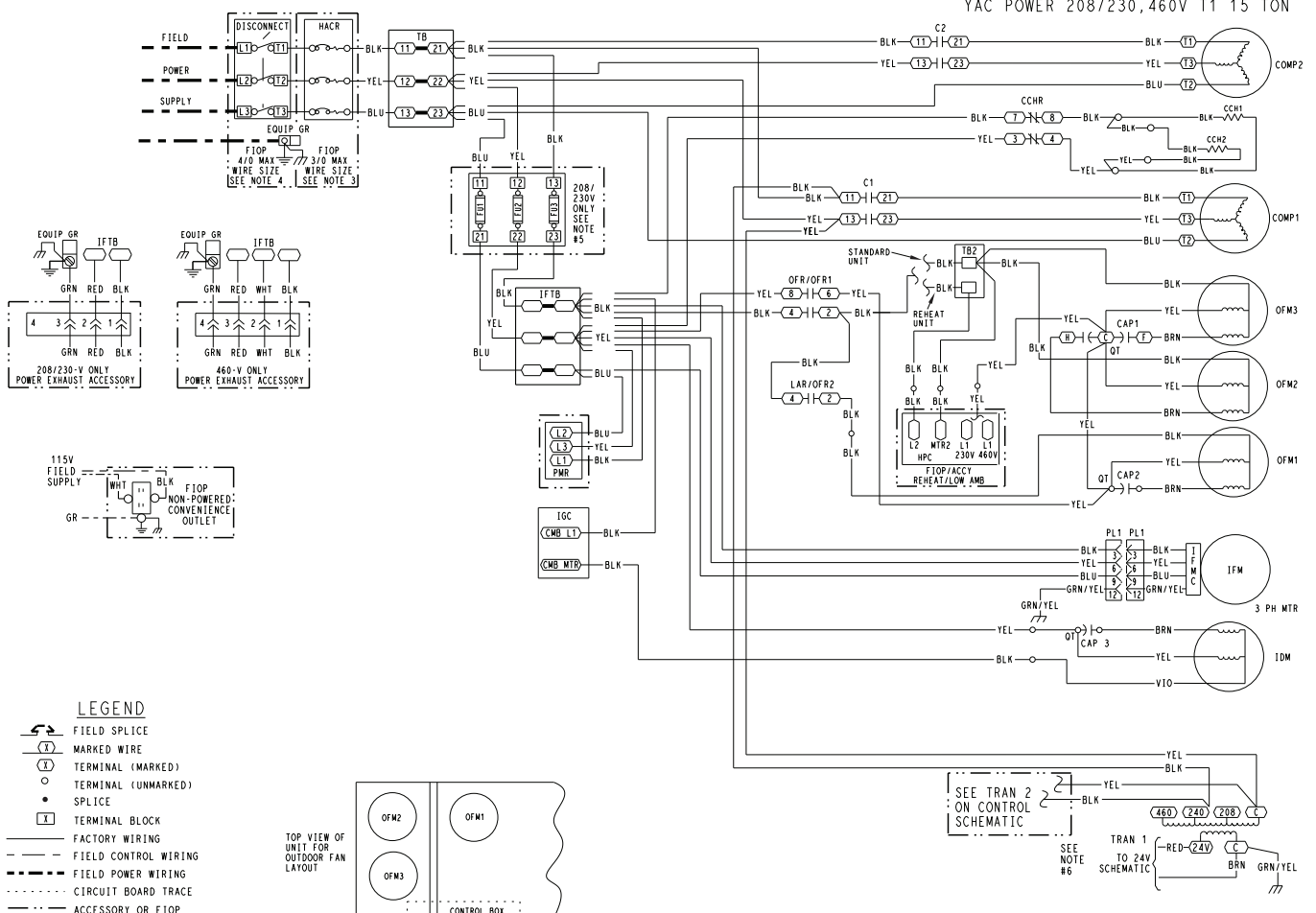

LEGEND

- FIELD SPLICE
- MARKED WIRE
- TERMINAL (MARKED)
- TERMINAL (UNMARKED)
- SPLICE
- TERMINAL BLOCK
- FACTORY WIRING
- FIELD CONTROL WIRING
- FIELD POWER WIRING
- CIRCUIT BOARD TRACE
- ACCESSORY OR FIOP
- TO INDICATE COMMON POTENTIAL ONLY: NOT TO REPRESENT WIRING

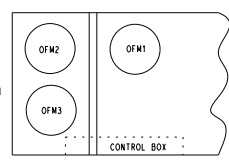

- NOTES:
1. IF ANY OF THE ORIGINAL WIRE FURNISHED MUST BE REPLACED, IT MUST BE REPLACED WITH TYPE 90 C WIRE OR ITS EQUIVALENT.
 2. COMPRESSOR AND FAN MOTORS ARE THERMALLY PROTECTED. THREE PHASE MOTORS ARE PROTECTED AGAINST PRIMARY SINGLE PHASING CONDITIONS.
 3. USE COPPER, COPPER CLAD ALUMINUM OR ALUMINUM CONDUCTORS.
 4. USE COPPER CONDUCTORS ONLY.
 5. F1, F2, AND F3, REPLACE WITH 250V 60A BUSSMAN FRNR 60.
 6. TRANSFORMER IS DEDICATED BASED ON UNIT VOLTAGE. TAPS ONLY SHOWN TO SIMPLIFY SCHEMATIC. 208/230V UNIT TRAN IS WIRED FOR 230V UNIT. IF UNIT IS TO BE RUN WITH 208V POWER SUPPLY DISCONNECT BLK WIRE FROM 230V TAP AND CONNECT TO 200V TAP.

ACCY	ACCESSORY	HS	HALL EFFECT SENSOR	OFM	OUTDOOR FAN MOTOR
AMB	AMBIENT	I	IGNITOR	OL	OVERLOAD
C	CONTACTOR, COMPRESSOR	IAO	INDOOR AIR QUALITY SENSORS	PL	PLUG ASSEMBLY
CAP	CAPACITOR	IDM	INDUCED DRAFT MOTOR	POT	POTENTIOMETER
CB	CIRCUIT BREAKER	IFCB	INDOOR FAN CIRCUIT BREAKER	PMR	PHASE MONITOR RELAY
CCH	CRANKCASE HEATER	IFMC	INDOOR FAN MOTOR	QT	QUADRUPEL TERMINAL
CCHR	CRANKCASE HEATER RELAY	IFM	INDOOR FAN CONTROLLER	RAT	RETURN AIR RELATIVE HUMIDITY
CMB	COMBUSTION	IGC	INTEGRATED GAS CONTROL	RAT	RETURN AIR TEMP. SENSOR
COFS	CONDENSATE OVERFLOW SWT	JMP	JUMPER	RDV	REHEAT DISCHARGE VALVE
COMP	COMPRESSOR MOTOR	LA	LOW AMBIENT	RS	ROLLOUT SWITCH
DDC	DIRECT DIGITAL CONTROL	LAV	LIQUID DIVERTER VALVE	SAT	SUPPLY AIR TEMP. SENSOR
ERV	ENERGY RECOVERY VENTILATOR	LPS	LOW PRESSURE SWITCH	SEN	SENSOR
FIOP	FACTORY INSTALLED OPTION	LSM	LIMIT SWITCH (MANUAL RESET)	SPRH	SPACE RELATIVE HUMIDITY
FIS	FAN LIMIT SWITCH	LS	LIMIT SWITCH	SPT	SPACE TEMPERATURE SENSOR
FPT	FREEZE PROTECTION THERMOSTAT	LTO	LOW TEMPERATURE LOCKOUT	SPTO	SPACE TEMPERATURE OFFSET
FSD	FIRE SHUT DOWN	MV	MAIN GAS VALVE	STD	STANDARD
FS	FLAME SENSOR	MGV	VOLTAGE RESTRICTOR	TB	TERMINAL BLOCK
FU	FUSE	MTR	MOTOR	TDR	TIME DELAY RELAY (WINTER START)
GND	GROUND	MTS	MIXED AIR TEMPERATURE SWITCH	TRN	TRANSFORMER
GVR	GAS VALVE RELAY	OAO	OUTDOOR AIR QUALITY	UCB	UNIT CONTROL BOARD
HPC	HEAD PRESSURE CONTROL	OARH	OUTSIDE AIR RELATIVE HUMIDITY		
HPS	HIGH PRESSURE SWITCH	OAT	OUTDOOR AIR TEMP. SENSOR		

50TMO01914 A

Typical wiring diagrams (cont)

TYPICAL POWER WIRING DIAGRAM — RGV180 575-3-60 UNIT WITH ELECTROMECHANICAL CONTROLLERS

YAC POWER 575V T1 15 TON, T2 12.5 TON

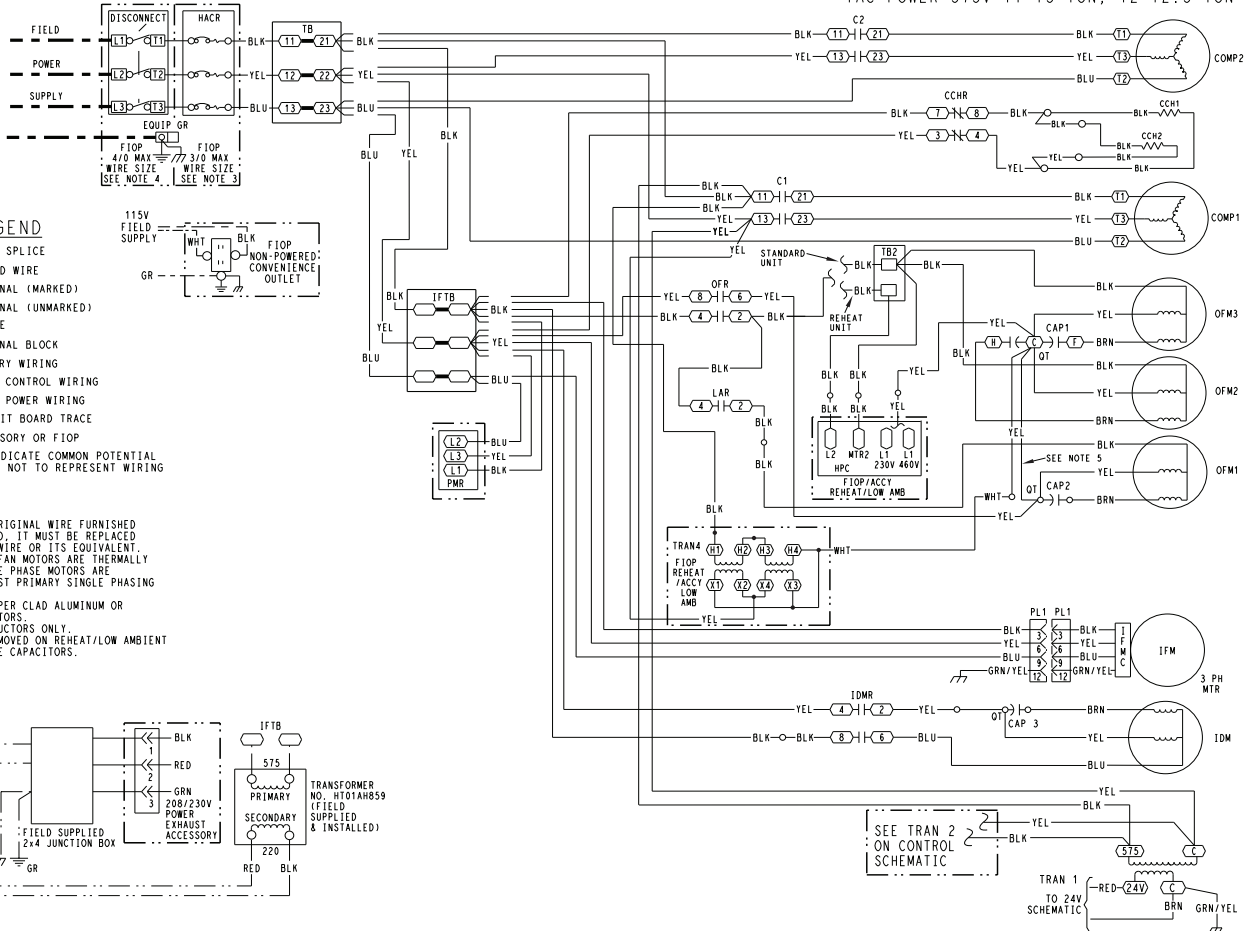

LEGEND

- FIELD SPLICE
- MARKED WIRE
- TERMINAL (MARKED)
- TERMINAL (UNMARKED)
- SPLICE
- TERMINAL BLOCK
- FACTORY WIRING
- FIELD CONTROL WIRING
- FIELD POWER WIRING
- CIRCUIT BOARD TRACE
- ACCESSORY OR FIOP
- TO INDICATE COMMON POTENTIAL ONLY; NOT TO REPRESENT WIRING

NOTES:

1. IF ANY OF THE ORIGINAL WIRE FURNISHED MUST BE REPLACED, IT MUST BE REPLACED WITH TYPE 90 C WIRE OR ITS EQUIVALENT.
2. COMPRESSOR AND FAN MOTORS ARE THERMALLY PROTECTED. THREE PHASE MOTORS ARE PROTECTED AGAINST PRIMARY SINGLE PHASING CONDITIONS.
3. USE COPPER, COPPER CLAD ALUMINUM OR ALUMINUM CONDUCTORS.
4. USE COPPER CONDUCTORS ONLY.
5. THIS WIRE IS REMOVED ON REHEAT/LOW AMBIENT UNITS TO ISOLATE CAPACITORS.

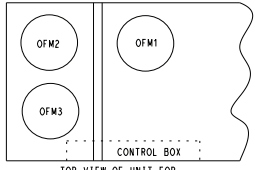
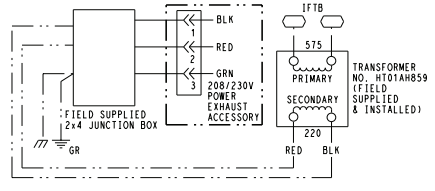

ACCY	ACCESSORY	I	IGNITOR	OFM	OUTDOOR FAN MOTOR
AMB	AMBIENT	IAQ	INDOOR AIR QUALITY SENSORS	OFM1	OUTDOOR FAN MOTOR 1
C	CONTACTOR, COMPRESSOR	IDM	INDUCED DRAFT MOTOR	OFM2	OUTDOOR FAN MOTOR 2
CAP	CAPACITOR	IFCB	INDOOR FAN CIRCUIT BREAKER	OFM3	OUTDOOR FAN MOTOR 3
CB	CIRCUIT BREAKER	IFM	INDOOR FAN MOTOR		
CCH	CRANKCASE HEATER	IFMC	INDOOR FAN MOTOR CONTROLLER		
CCHR	CRANKCASE HEATER RELAY	IGC	INTEGRATED GAS CONTROL		
CMB	COMBUSTION	IFTB	INDOOR FAN TERMINAL BLOCK		
COS	CONDENSATE OVERFLOW SWT	JMP	JUMPER		
COMP	COMPRESSOR MOTOR	LA	LOW AMBIENT		
DDC	DIRECT DIGITAL CONTROL	LAR	LOW AMBIENT RELAY		
ENR	ELECTRIC HEATER RELAY	LDV	LIQUID DIVERTER VALVE		
ERV	ENERGY RECOVERY VENTILATOR	LPS	LOW PRESSURE SWITCH		
FIOP	FACTORY INSTALLED OPTION	LSM	LIMIT SWITCH (MANUAL RESET)		
FLS	FAN LIMIT SWITCH	LTLO	LOW TEMPERATURE LOCKOUT		
FPT	FREEZE PROTECTION THERMOSTAT	MGV	MAIN GAS VALVE		
FSD	FIRE SHUT DOWN	MOV	VOLTAGE RESTRICTOR		
FS	FUSE	MTR	MOTOR		
FU	FUSE	MTS	MIXED AIR TEMPERATURE SWITCH		
GND	GROUND	OAO	OUTDOOR AIR QUALITY		
GVR	GAS VALVE RELAY	OARH	OUTSIDE AIR RELATIVE HUMIDITY		
HPC	HEAD PRESSURE CONTROL	OAT	OUTDOOR AIR TEMP. SENSOR		
HPS	HIGH PRESSURE SWITCH				
HS	HALL EFFECT SENSOR				

50TM001916 C

TYPICAL CONTROL WIRING DIAGRAM — RAV090-120 208-230/460/575-3-60 UNIT WITH ELECTROMECHANICAL CONTROL AND W7220 ECONOMIZER

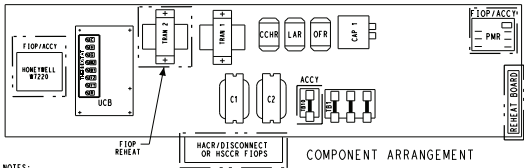

- NOTES:
1. TERMINAL BOARD SCHEMATIC LAYOUT DOES NOT MATCH ACTUAL TERMINAL BOARD LAYOUT.
 2. TERMINAL BOARD JUMPERS 1, 2 AND 3 ARE CUT FOR REHEAT UNITS ONLY.
 3. REMOVE DESIGNATED JUMPERS ON TERMINAL BOARD WHEN ADDING SMOKE DETECTORS, OCCUPANCY AND REMOTE SHUTDOWN.
 4. USE ABC AS COARSE AND AS POT FINE ADJUSTMENTS FOR SETTING HIGH FAN SPEED. LOW SPEED IS AN OFFSET BASED ON DIP SWITCHES.
 5. 2-PIN LOW SPEED DIP SWITCH POSITIONS ARE FACTORY SET AS SHOWN. EXCEPTION ON T1 8.5 TON UNITS. THESE ARE SET TO "ON-OFF". HARDSTART AND CUTOFF SET TO "MIN". JUMPER P1N ON TOP 2-PIN AS SHOWN.
 7. THE W WIRE COLOR IS FOR DIFFERENTIATION WITHIN THIS SCHEMATIC.
 8. TRANSFORMER IS DEDICATED BASED ON UNIT VOLTAGE. TAPS ONLY SHOWN TO SIMPLIFY SCHEMATIC. 208/230V UNIT TRN 1 IS WIRED FOR 230V UNIT. IF UNIT IS TO BE RUN WITH 208V POWER SUPPLY DISCONNECT BLK WIRE FROM 230V TAP AND CONNECT TO 208V TAP.
 9. TB4 LOCATED IN HEAT SECTION.
 10. TO CONVERT TO A SINGLE STAGE HEATER MOVE VIOLET WIRE AT TB4 TO CONNECT WITH WHITE WIRE.

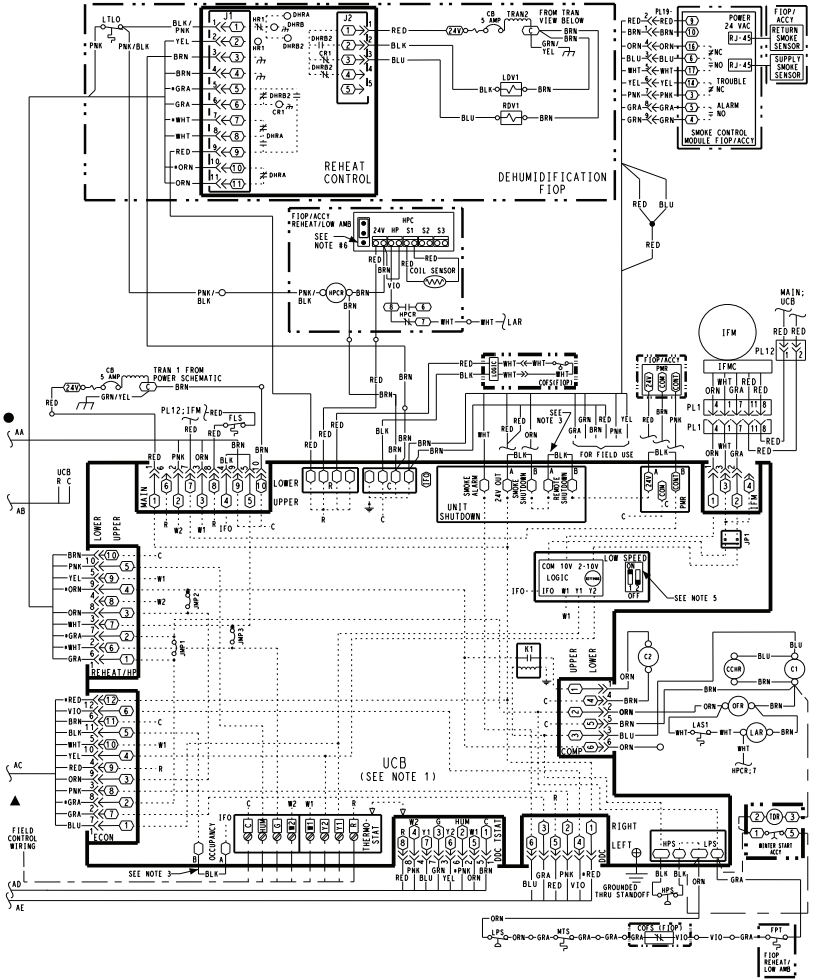
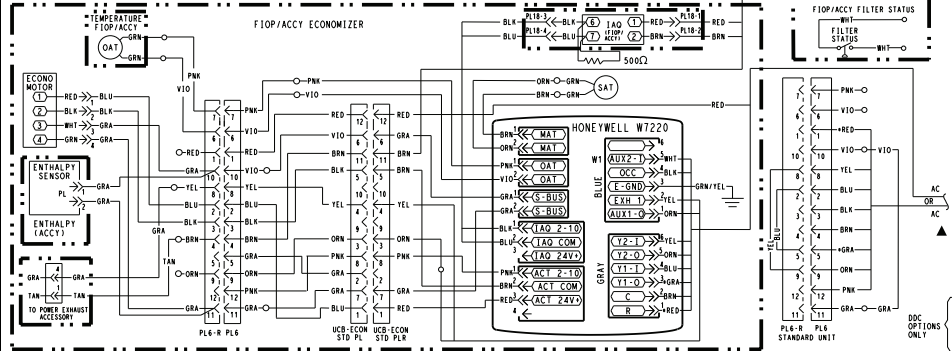
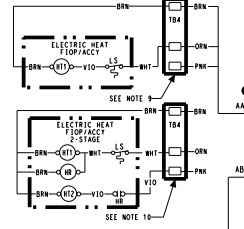
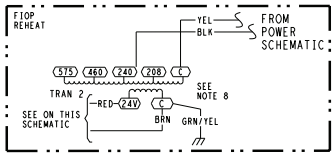

PAC CONTROL 230/460/575V T1 7.5-10 TON, T2 6-8.5 TON
48TMO05715 I E

TYPICAL CONTROL WIRING DIAGRAM — RAV150 208-230/460/575-3-60 UNIT WITH ELECTROMECHANICAL CONTROL AND W7220 ECONOMIZER

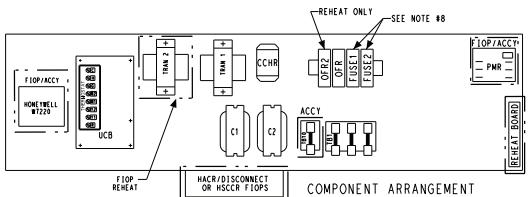

- NOTES:
1. UCB SCHEMATIC LAYOUT DOES NOT MATCH ACTUAL TERMINAL BOARD LAYOUT.
 2. TERMINAL BOARD JUMPERS 1, 2 AND 3 ARE CUT FOR REHEAT UNITS ONLY.
 3. REMOVE DESIGNATED JUMPERS ON UCB WHEN ADDING SMOKE DETECTORS, OCCUPANCY AND REMOTE SHUTDOWN.
 4. USE ABC AS COARSE AND AS POT FINE ADJUSTMENTS FOR SETTING HIGH FAN SPEED. LOW SPEED IS AN OFFSET BASED ON DIP SWITCHES.
 5. 2-PIN LOW SPEED DIP SWITCH POSITIONS ARE FACTORY SET AS SHOWN.
 6. HARDSTART AND CUTOFF SET TO "MIN" JUMPER PIN ON TOP 2-PINS AS SHOWN.
 7. THE * WIRE COLOR IS FOR DIFFERENTIATION WITHIN THIS SCHEMATIC.
 8. FUSES FOR 230V ARE LOCATED IN CONTROL BOX. FUSES FOR 460/575V ARE LOCATED BELOW THE CONTROL BOX.
 9. T84 LOCATED IN HEAT SECTION.
 10. TO CONVERT TO A SINGLE STAGE HEATER MOVE VIOLET WIRE AT T84 TO CONNECT WITH WHITE WIRE.
 11. TRANSFORMER IS DEDICATED BASED ON UNIT VOLTAGE. TAPS ONLY SHOWN TO SIMPLIFY SCHEMATIC. 208/230V UNIT TRN IS WIRED FOR 230V UNIT. IF UNIT IS TO BE RUN WITH 230V POWER SUPPLY DISCONNECT BLK WIRE FROM 230V TAP AND CONNECT TO 230V TAP.

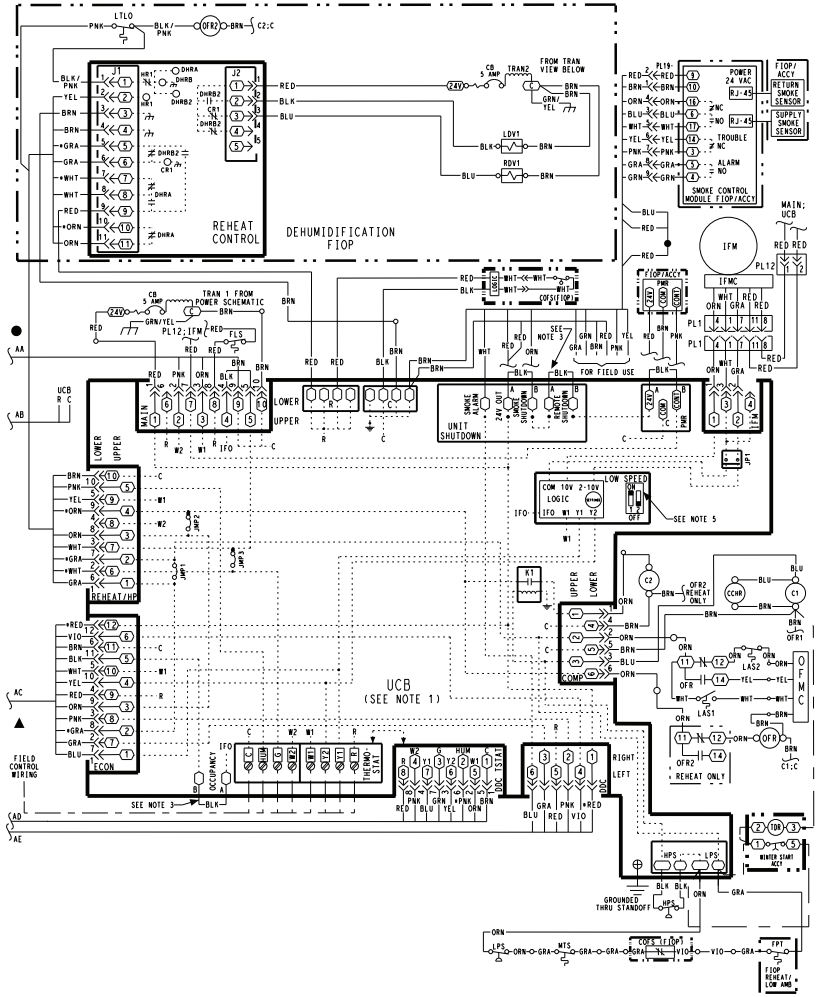
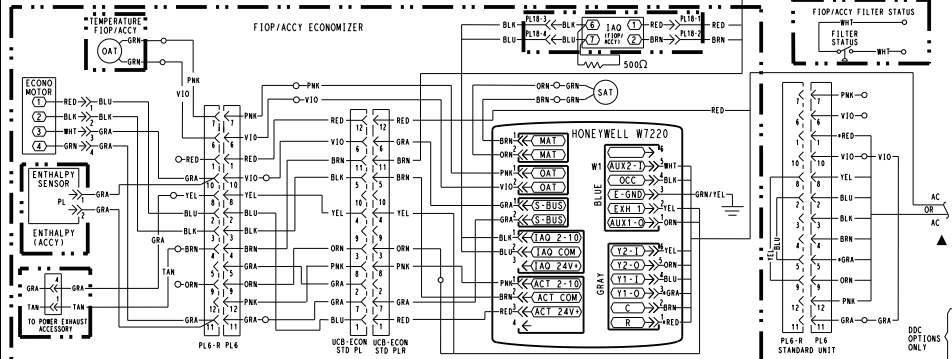
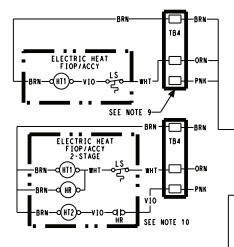
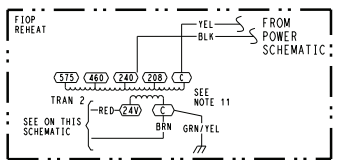

PAC CONTROL 230/460/575V T1 12.5 TON, T2 10 TON 481M005985 E

Typical wiring diagrams (cont)

TYPICAL POWER WIRING DIAGRAM — RAV150 208-230/3/60 UNIT WITH ELECTROMECHANICAL CONTROLLER

PAC POWER 230V
T1 12.5 TON, T2 10 TON
HP POWER 230V
T1 10 TON, T2 8.5 TON

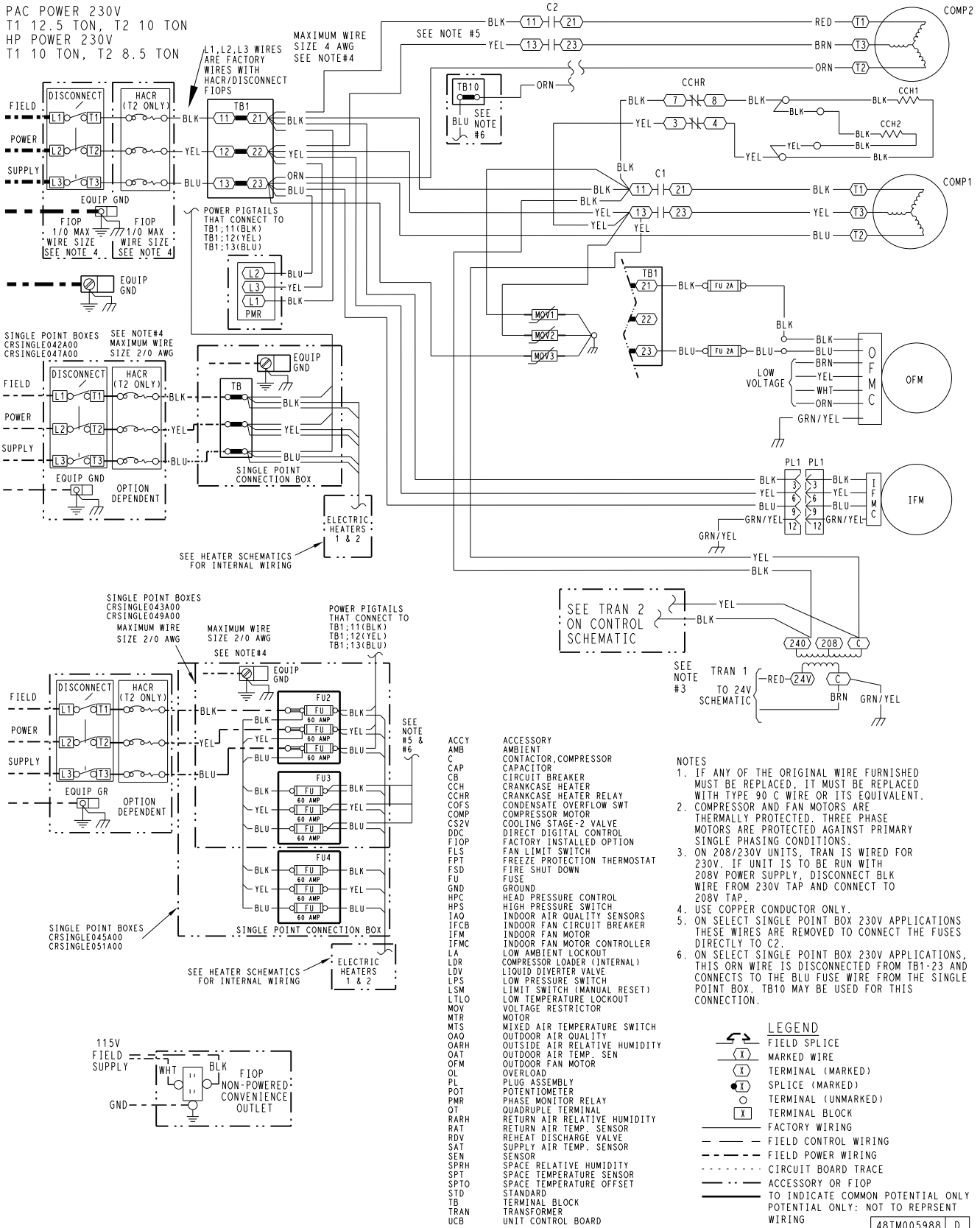

TYPICAL CONTROL WIRING DIAGRAM — RAV180 230/460/575-3-60 UNIT WITH ELECTROMECHANICAL CONTROLLER

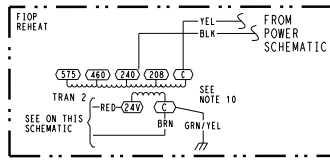
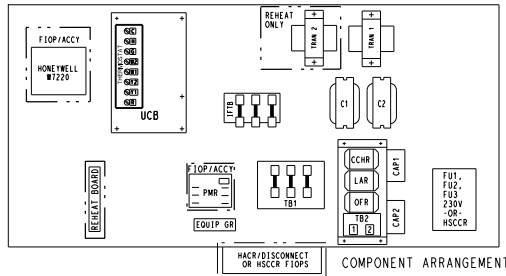

NOTES:

1. UCB LAYOUT DOES NOT MATCH ACTUAL TERMINAL BOARD LAYOUT.
2. TERMINAL BOARD JUMPERS 1, 2 AND 3 ARE CUT FOR REHEAT UNITS ONLY.
3. REMOVE DESIGNATED JUMPERS ON TERMINAL BOARD WHEN ADDING SMOKE DETECTORS, OCCUPANCY AND REMOTE SHUTDOWN.
4. USE ABC AS COARSE AND AS POT FINE ADJUSTMENTS FOR SETTING HIGH FAN SPEED. LOW SPEED IS AN OFFSET BASED ON DIP SWITCHES.
5. 2-PIN LOW SPEED DIP SWITCH POSITIONS ARE FACTORY SET AS SHOWN.
6. HARDSTART AND CUTOFF SET TO "MIN". JUMPER PIN ON TOP 2-PINS AS SHOWN.
7. THE * WIRE COLOR IS FOR DIFFERENTIATION WITHIN THIS SCHEMATIC.
8. TB4 LOCATED IN HEAT SECTION.
9. TO CONVERT TO A SINGLE STAGE HEATER MOVE VIOLET WIRE AT TB4 TO CONNECT WITH WHITE WIRE.
10. TRANSFORMER IS DEDICATED BASED ON UNIT VOLTAGE. TAPS ONLY SHOWN TO SIMPLIFY SCHEMATIC. 208/230V UNIT TRAN IS WIRED FOR 230V UNIT. IF UNIT IS TO BE RUN WITH 208V POWER SUPPLY DISCONNECT BLK WIRE FROM 230V TAP AND CONNECT TO 208V TAP.

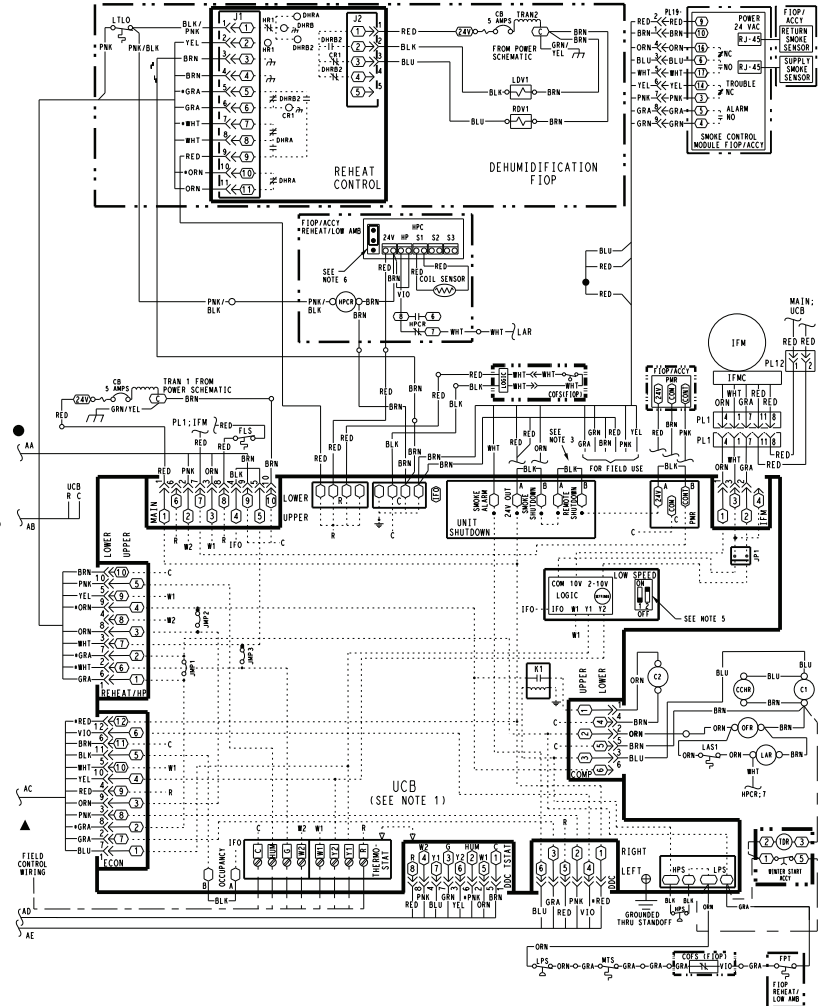
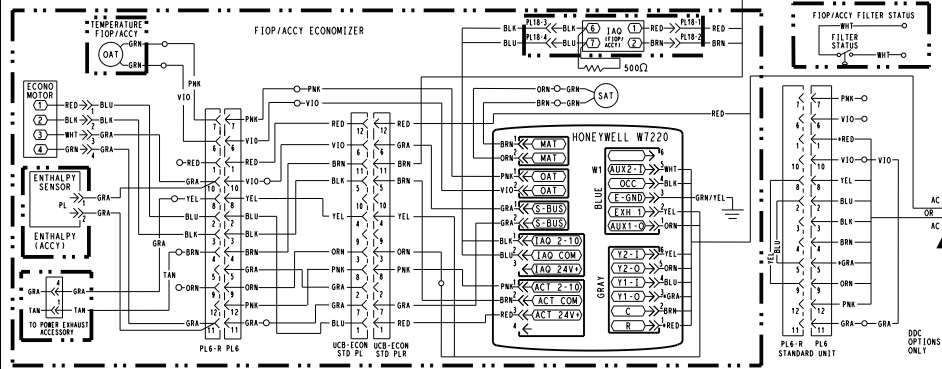
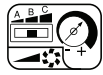

PAC CONTROL 230/460/575V T1 15 TON, T2 12.5 TON
50TMD01910 C

Typical wiring diagrams (cont)

TYPICAL POWER WIRING DIAGRAM — RAV180 208-230/460-3-60 UNIT WITH ELECTROMECHANICAL CONTROLLERS

PAC POWER 208/230, 460V T1 15 TON, T2 12.5 TON
HP POWER 208/230, 460V T1 12.5 TON, T2 10 TON

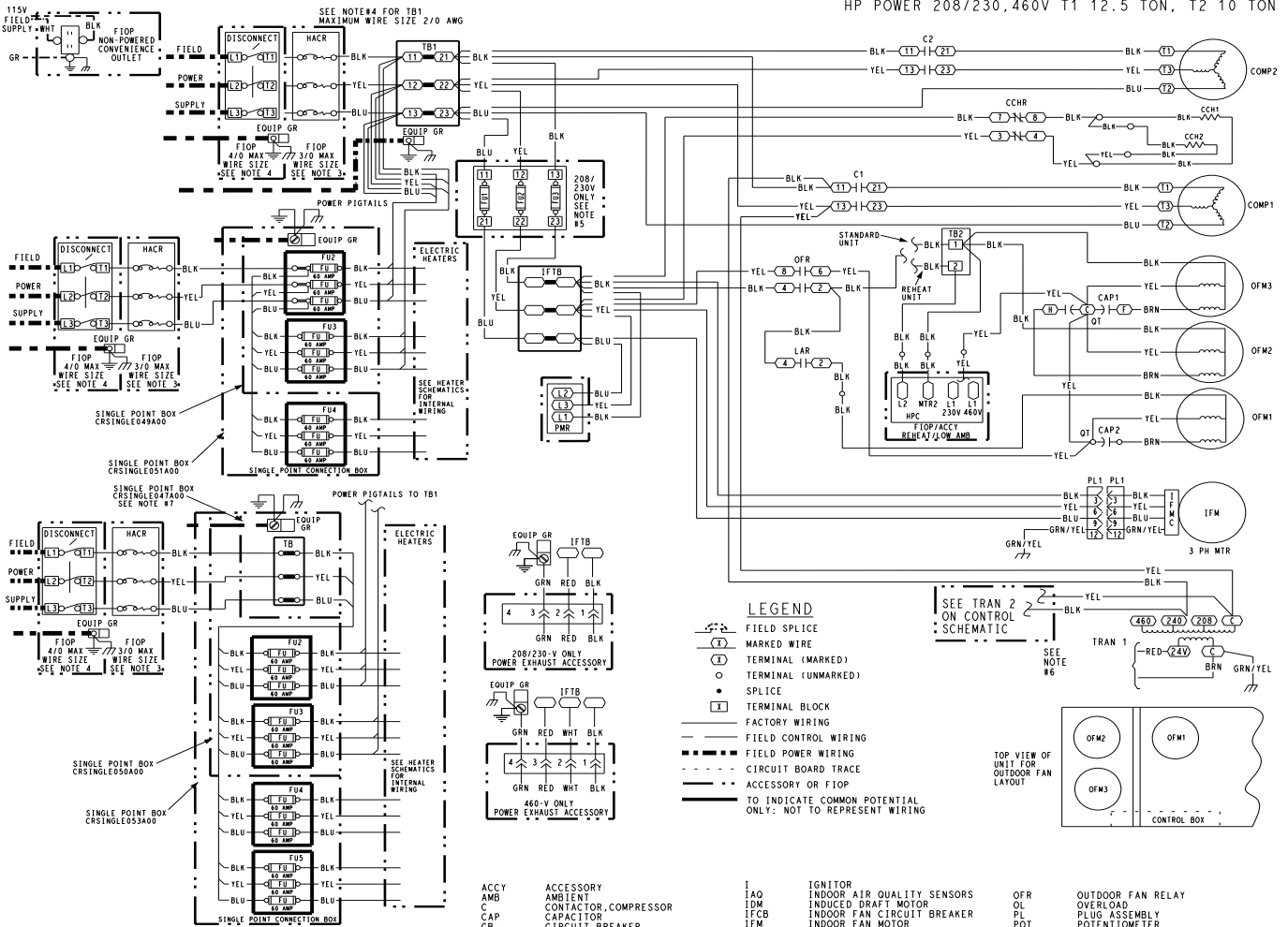

- NOTES:
- IF ANY OF THE ORIGINAL WIRE FURNISHED MUST BE REPLACED IT MUST BE REPLACED WITH TYPE 90 C WIRE OR ITS EQUIVALENT.
 - COMPRESSOR AND FAN MOTORS ARE THERMALLY PROTECTED. THREE PHASE MOTORS ARE PROTECTED AGAINST PRIMARY SINGLE PHASING CONDITIONS.
 - USE COPPER, COPPER CLAD ALUMINUM OR ALUMINUM CONDUCTORS.
 - USE COPPER CONDUCTORS ONLY.
 - FUS, FUS2, AND FUS3, REPLACE WITH 250V 60A BUSSMAN FANR 60.
 - TRANSFORMER IS DEDICATED BASED ON UNIT VOLTAGE. TAPS ONLY SHOWN TO SIMPLIFY SCHEMATIC. 208/230V UNIT TRAN IS WIRED FOR 230V UNIT. IF UNIT IS TO BE RUN WITH 208V POWER SUPPLY DISCONNECT BLK WIRE FROM 230V TAP AND CONNECT TO 200V TAP.
 - CRSINGLE04TA00 IS ONLY A TERMINAL BLOCK TO DISTRIBUTE POWER TO THE CONTROL BOX T81 AND ELECTRIC HEATERS.

ACCV	ACCESSORY	I	IGNITOR	OFR	OUTDOOR FAN RELAY
AMB	AMBIENT	IAQ	INDOOR AIR QUALITY SENSORS	OL	OVERLOAD
C	CONTACTOR, COMPRESSOR	IDM	INDUCED DRAFT MOTOR	OL	OVERLOAD
CAP	CAPACITOR	IFCB	INDOOR FAN CIRCUIT BREAKER	PL	PLUG ASSEMBLY
CB	CIRCUIT BREAKER	IFM	INDOOR FAN MOTOR	POT	POTENTIOMETER
CCH	CRANKCASE HEATER	IFMC	INDOOR FAN CONTROLLER	PMR	PHASE MONITOR RELAY
CCHR	CRANKCASE HEATER RELAY	IGC	INTEGRATED GAS CONTROL	OT	QUADRUPLE TERMINAL
CMB	COMBUSTION	IGC	INDOOR FAN TERMINAL BLOCK	RARH	RETURN AIR RELATIVE HUMIDITY
COPFS	CONDENSATE OVERFLOW SWT	JMP	JUMPER	RAT	RETURN AIR TEMP. SENSOR
COMP	COMPRESSOR MOTOR	LA	LOW AMBIENT	RVD	REHEAT DISCHARGE VALVE
DDC	DIRECT DIGITAL CONTROL	LAR	LOW AMBIENT RELAY	RS	ROLLOUT SWITCH
EHR	ELECTRIC HEATER RELAY	LDV	LIQUID DIVERTER VALVE	RVS	REVERSING VALVE SOLENOID RELAY
ERV	ENERGY RECOVERY VENTILATOR	LPS	LOW PRESSURE SWITCH	SAT	SUPPLY AIR TEMP. SENSOR
F1OP	FACTORY INSTALLED OPTION	LSM	LIMIT SWITCH (MANUAL RESET)	SEN	SENSOR
FLS	FAN LIMIT SWITCH	LS	LIMIT SWITCH	SPRH	SPACE RELATIVE HUMIDITY
FPT	FREEZE PROTECTION THERMOSTAT	LTL0	LOW TEMPERATURE LOCKOUT	STD	SPACE TEMPERATURE SENSOR
FSD	FIRE SHUT DOWN	MGV	MAIN GAS VALVE	SPTO	SPACE TEMPERATURE OFFSET
FSS	FLAME SENSOR	MOV	VOLTAGE RESTRICTOR	STD	STANDARD
FU	FUSE	MTR	MOTOR	TB	TERMINAL BLOCK
GND	GROUND	MIS	MIXED AIR TEMPERATURE SWITCH	TBR	TEMPERATURE BYPASS RELAY
GVR	GAS VALVE RELAY	OAQ	OUTDOOR AIR QUALITY	TR	TIME DELAY RELAY (WINTER START)
HPC	HEAD PRESSURE CONTROL	OARH	OUTSIDE AIR RELATIVE HUMIDITY	TRAN	TRANSFORMER
HPS	HIGH PRESSURE SWITCH	OAT	OUTDOOR AIR TEMP. SENSOR	UCB	UNIT CONTROL BOARD
HS	HALL EFFECT SENSOR	OTM	OUTDOOR FAN MOTOR		

50TM001913 | D

Typical wiring diagrams (cont)

TYPICAL POWER WIRING DIAGRAM — RAV180 575-3-60 UNIT WITH ELECTROMECHANICAL CONTROLLERS

PAC POWER 575V T1 15 TON, T2 12.5 TON
HP POWER 575V T1 12.5 TON, T2 10 TON

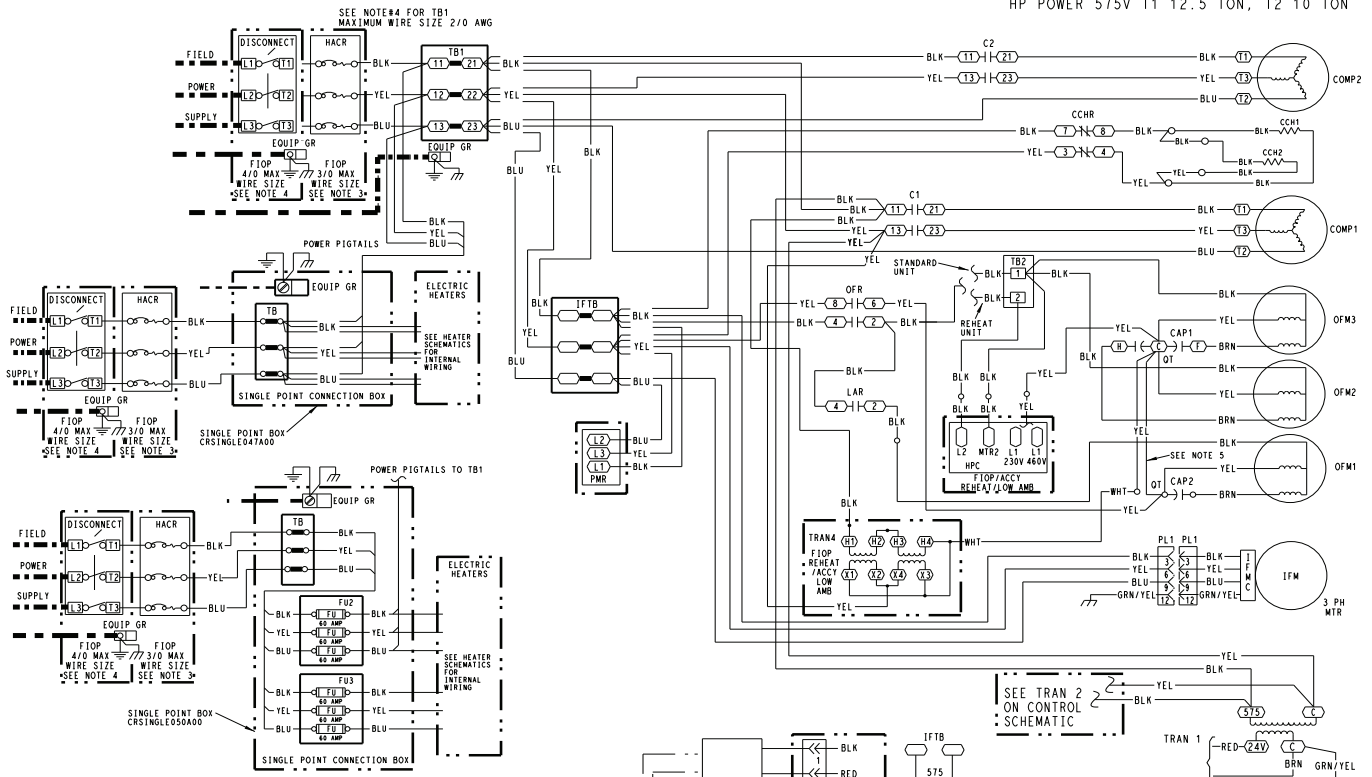

LEGEND

- FIELD SPlice
- MARKED WIRE
- TERMINAL (MARKED)
- TERMINAL (UNMARKED)
- SPlice
- TERMINAL BLOCK
- FACTORY WIRING
- FIELD CONTROL WIRING
- FIELD POWER WIRING
- CIRCUIT BOARD TRACE
- ACCESSORY OR FIOP
- TO INDICATE COMMON POTENTIAL ONLY; NOT TO REPRESENT WIRING

NOTES:

1. IF ANY OF THE ORIGINAL WIRE FURNISHED MUST BE REPLACED, IT MUST BE REPLACED WITH TYPE 90 C WIRE OR ITS EQUIVALENT.
2. COMPRESSOR AND FAN MOTORS ARE THERMALLY PROTECTED. THREE PHASE MOTORS ARE PROTECTED AGAINST PRIMARY SINGLE PHASING CONDITIONS.
3. USE COPPER, COPPER CLAD ALUMINUM OR ALUMINUM CONDUCTORS.
4. USE COPPER CONDUCTORS ONLY.
5. THIS WIRE IS REMOVED ON REHEAT/LOW AMBIENT UNITS TO ISOLATE CAPACITORS.

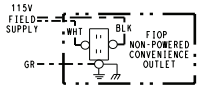

ACCY	ACCESSORY	I	IGNITOR	OFR	OUTDOOR FAN RELAY
AMB	AMBIENT	IAO	INDOOR AIR QUALITY SENSORS	OL	OVERLOAD
C	CONTACTOR/COMPRESSOR	IDM	INDUCED DRAFT MOTOR	PL	PLUG ASSEMBLY
CAP	CAPACITOR	IFCB	INDOOR FAN CIRCUIT BREAKER	POT	POTENTIOMETER
CB	CIRCUIT BREAKER	IFM	INDOOR FAN MOTOR	PMR	PHASE MONITOR RELAY
CCH	CRANKCASE HEATER	IFMC	INDOOR FAN CONTROLLER	QTR	QUADRUPLE TERMINAL
CCHR	CRANKCASE HEATER RELAY	IGC	INTEGRATED GAS CONTROL	RAT	RETURN AIR TEMP. SENSOR
CMB	COMBUSTION	IFTB	INDOOR FAN TERMINAL BLOCK	RDV	REHEAT DISCHARGE VALVE
COFS	CONDENSATE OVERFLOW SWT	JMP	JUMPER	RS	ROLLOUT SWITCH
COMP	COMPRESSOR MOTOR	LA	LOW AMBIENT	RVSR	REVERSING VALVE SOLENOID RELAY
DDC	DIRECT DIGITAL CONTROL	LAR	LOW AMBIENT RELAY	SAT	SUPPLY AIR TEMP. SENSOR
EHR	ELECTRIC HEATER RELAY	LDV	LIQUID DIVERTER VALVE	SPT	SPACE TEMPERATURE SENSOR
ERV	ENERGY RECOVERY VENTILATOR	LPS	LOW PRESSURE SWITCH	SPTO	SPACE TEMPERATURE OFF-SET
FIOP	FACTORY INSTALLED OPTION	LSM	LIMIT SWITCH (MANUAL RESET)	STD	STANDARD
FLS	FAN LIMIT SWITCH	LTO	LIMIT SWITCH	TB	TERMINAL BLOCK
FPT	FREEZE PROTECTION THERMOSTAT	LTV	LOW TEMPERATURE LOCKOUT	TBR	TEMPERATURE BYPASS RELAY
FSD	FIRE SHUT DOWN	LTV	LOW TEMPERATURE LOCKOUT	TDR	TIME DELAY RELAY (WINTER START)
FS	FLAME SENSOR	MTR	MOTOR	TRAN	TRANSFORMER
FU	FUSE	MOV	MOTOR VOLTAGE RESTRICTOR	UCB	UNIT CONTROL BOARD
GND	GROUND	MTR	MOTOR		
GVR	GAS VALVE RELAY	MTR	MIXED AIR TEMPERATURE SWITCH		
HPC	HEAD PRESSURE CONTROL	OAO	OUTDOOR AIR QUALITY		
HPS	HIGH PRESSURE SWITCH	OARH	OUTSIDE AIR RELATIVE HUMIDITY		
HS	HALL EFFECT SENSOR	OAT	OUTDOOR AIR TEMP. SENSOR		

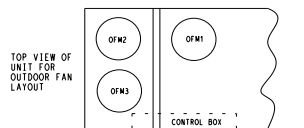

50TMO01915 D

Sequence of operation

General

The sequence below describes the sequence of operation for an electromechanical unit with and without a factory-installed EconoMi\$er® X (W7220 controller). For information regarding a direct digital controller, see the start-up, operations, and troubleshooting manual for the applicable controller.

Electromechanical Units with No Economizer

Cooling (two-stage units)

When the thermostat calls for cooling, terminals G and Y1 are energized. The indoor fan will run at the low fan speed and the C1 compressor contactor (CC) is energized causing the compressor and outdoor fan to run. The low indoor fan speed is 50% or 60% of the user set fan speed depending on unit size.

If additional cooling is needed, the thermostat will add the call for Y2. This will increase the indoor fan speed to the user set fan speed and energize the C2 contactor and second compressor for full compressor capacity. The outdoor fan is the same speed for Y1 and Y2.

When the thermostat removes the call for Y2 but leaves the Y1, the indoor fan will slow to the reduced percentage of the user set fan speed, the C2 contactor will de-energize, the second compressor will turn off, and the outdoor fan will remain on. When the thermostat removes the call for Y1 the compressor contactor will de-energize shutting down the compressor and the outdoor fan. When the thermostat removes the call for G, the indoor fan will turn off after the specific unit fan off delay.

NOTE: Per ASHRAE 90.1-2019 and IECC-2018 standards, during the first stage cooling operation the Unit Control Board (UCB) will adjust the fan motor speed to provide 50% or 60% of the total cfm established for the unit.

Gas Heating (RGV units)

NOTE: RGV090-150 units have 2 stages of gas heat.

When the thermostat calls for heating, power is sent to W on the Integrated Gas Controller (IGC) board. An LED (light-emitting diode) on the IGC board turns on and remains on during normal operation. A check is made to ensure that the roll-out switch and limit switch are closed. If the check was successful, the induced-draft motor is energized, and when its speed is satisfactory, as proven by the flue gas pressure switch, the ignition activation period begins. The burners will ignite within 5 seconds. If the burners do not light, there is a 22 second delay before another 5 second attempt. This sequence is repeated for 15 minutes or until the burners light. If, after the 15 minutes, the burners still have not lit, heating is locked out. To reset the control, break 24 V power to the thermostat.

When ignition occurs, the IGC board will continue to monitor the condition of the roll-out switch, the limit switches, the flue gas pressure switch, as well as the flame sensor. 45 seconds after ignition occurs, assuming the unit is controlled through a room thermostat set for fan auto, the indoor-fan motor will energize (and the outdoor-air dampers will open to their minimum position). If, for some reason, the over-temperature limit opens prior to the start of the indoor

fan blower, the unit will shorten the 45 second delay to 5 seconds less than the time from initiation of heat to when the limit tripped. Gas will not be interrupted to the burners and heating will continue. Once the fan-on delay has been modified, it will not change back to 45 seconds until power is reset to the control. On units with 2 stages of heat, when additional heat is required, W2 closes and initiates power to the second stage of the main gas valve. When the thermostat is satisfied, W1 and W2 open and the gas valve closes, interrupting the flow of gas to the main burners. If the unit is controlled through a room thermostat set for fan auto, the indoor-fan motor will continue to operate for an additional 45 seconds then stop. A LED indicator is provided on the IGC to monitor operation.

Electric Heating (RAV units)

NOTE: RAV090-150 units are sold as cooling only. If electric heaters are required, use only factory-approved heaters. They will operate as follows.

Units have either 1 or 2 stages of electric heat. When the thermostat calls for heating, power is applied to G and the W1 terminals at the unit. The unit control will energize the indoor fan contactor and the first stage of electric heat. On units with two-stage heating, when additional heating is required, the second stage of electric heat (if equipped) will be energized when power is applied at the W2 terminal on the unit.

IMPORTANT: The thermostat must be configured for Electric Heat so it will energize G with the W1 call.

Electromechanical Units with Factory-Installed EconoMi\$er X

When free cooling is not available, the compressors will be controlled by the zone thermostat. When free cooling is available, the outdoor-air damper is modulated by the EconoMi\$er X control to provide a 50°F (10°C) to 55°F (13°C) mixed-air temperature into the zone. As the mixed air temperature fluctuates above 55°F (13°C) or below 50°F (10°C) dampers will be modulated (open or close) to bring the mixed-air temperature back within control. If mechanical cooling is utilized with free cooling, the outdoor-air damper will maintain its current position at the time the compressor is started. If the increase in cooling capacity causes the mixed-air temperature to drop below 45°F (7°C), then the outdoor-air damper position will be decreased to the minimum position. If the mixed-air temperature continues to fall, the outdoor-air damper will close. Control returns to normal once the mixed-air temperature rises above 48°F (9°C). The power exhaust fans will be energized and de-energized, if installed, as the outdoor-air damper opens and closes.

If field-installed accessory CO₂ sensors are connected to the EconoMi\$er X control, a demand controlled ventilation strategy will begin to operate. As the CO₂ level in the zone increases above the CO₂ set-point, the minimum position of the damper will be increased proportionally. As the CO₂ level decreases because of the increase in fresh air, the outdoor-air damper will be proportionally closed. For EconoMi\$er® X operation, there must be a thermostat call for the fan (G). If the unit is occupied and the fan is on, the

Sequence of operation (cont)

damper will operate at minimum position. Otherwise, the damper will be closed.

When the EconoMi\$er X control is in the occupied mode and a call for cooling exists (Y1 on the thermostat), the control will first check for indoor fan operation. If the fan is not on, then cooling will not be activated. If the fan is on, then the control will open the EconoMi\$er X damper to the minimum position.

On the initial power to the EconoMi\$er X control, it will take the damper up to 2 1/2 minutes before it begins to position itself. After the initial power-up, further changes in damper position can take up to 30 seconds to initiate. Damper movement from full closed to full open (or vice versa) will take between 1 1/2 and 2 1/2 minutes. If free cooling can be used as determined from the appropriate changeover command (switch, dry bulb, enthalpy curve, differential dry bulb, or differential enthalpy), then the control will modulate the dampers open to maintain the mixed-air temperature set-point at 50°F (10°C) to 55°F (13°C). If there is a further demand for cooling (cooling second stage — Y2 is energized), then the control will bring on compressor stage 1 to maintain the mixed-air temperature set-point. The EconoMi\$er X damper will be open at maximum position.

2-Speed Note: The EconoMi\$er X controller will adjust the damper position as the Indoor Fan Speed changes, per its configured values.

Heating

The sequence of operation for the heating is the same as an electromechanical unit with no economizer. The only difference is how the economizer acts. The economizer will stay at the Economizer Minimum Position while the evaporator fan is operating. The outdoor-air damper is closed when the indoor fan is not operating. Refer to Service and Maintenance Manual for further details.

Optional Hot Gas Re-Heat dehumidification system

Units with the factory equipped Hot Gas Re-Heat system option are capable of providing multiple modes of improved dehumidification as a variation of the normal cooling cycle. The Hot Gas Re-Heat system option includes additional valves in the liquid line and discharge line of each refrigerant circuit, a small reheat condenser coil downstream of the evaporator, and variable-speed control of some or all outdoor fans. Operation of the revised refrigerant circuit for each mode is described below.

The Hot Gas Re-Heat system provides three sub-modes of operation: Cool, Reheat1, and Reheat2.

Cool mode — Provides a normal ratio of Sensible and Latent Cooling effect from the evaporator coil.

Reheat1 — Provides increased Latent Cooling while slightly reducing the Sensible Cooling effect.

Reheat2 — Provides normal Latent Cooling but with null or minimum Sensible Cooling effect delivered to the space.

The Reheat1 and Reheat2 modes are available when the unit is not in a Heating mode and when the Low Ambient Lockout switch is closed.

Refer to the following figures for piping flow diagrams.

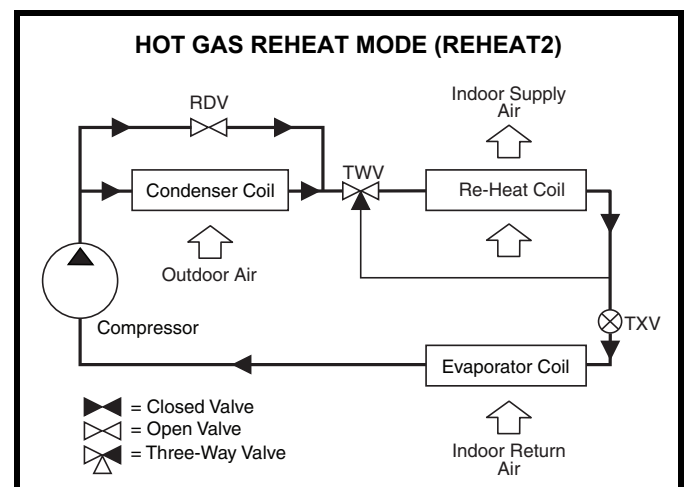
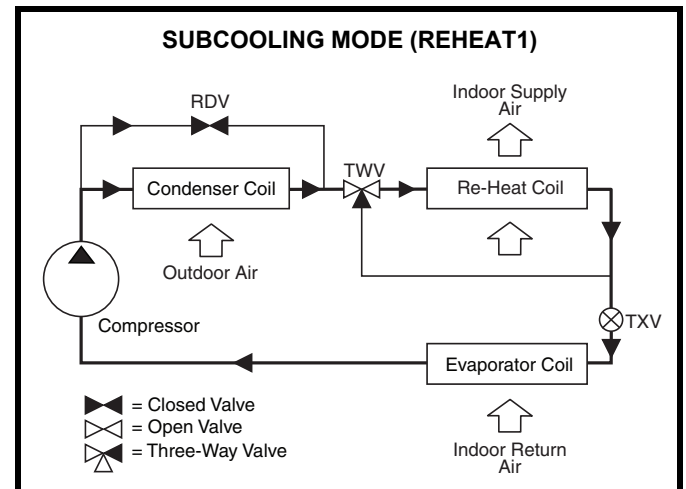
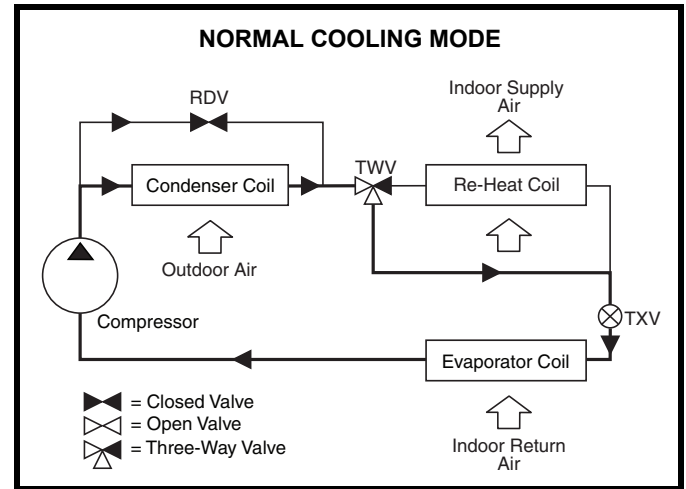

LEGEND

- RDV** — Reheat Discharge Valve
- TWV** — Three-Way Valve
- TXV** — Thermostatic Expansion Valve

Application data

Minimum operating ambient temperature (cooling)

In mechanical cooling mode, your RGV/RAV rooftop unit can safely operate down to an outdoor ambient temperature of 40°F (4°C) (0°F [-18°C] for size 150 models). It is possible to provide cooling at lower outdoor ambient temperatures by using less outside air, economizers, and/or accessory low ambient kits.

Maximum operating ambient temperature (cooling)

The maximum operating ambient temperature for cooling mode is 125°F (52°C) except for size 150 models with 120°F (49°C). While cooling operation above 115°F (46°C) [120°F (49°C) for size 150 models] may be possible, it could cause either a reduction in performance, reliability, or a protective action by the unit's internal safety devices.

Multiple motor and drive packages

Some applications need larger horsepower motors, some need more airflow, and some need both. Regardless of the case, your RGV/RAV expert has a factory installed combination to meet your application. A wide selection of motors are available, factory installed, to handle nearly any application.

Stainless steel heat exchanger (RGV units only)

The stainless steel heat exchanger option provides the tubular heat exchanger be made out of a minimum 20 gauge type 409 stainless steel for applications where the mixed air to the heat exchanger is expected to drop below 45°F (7°C). Stainless steel may be specified on applications where the presence of airborne contaminants require its use (applications such as paper mills) or in area with very high outdoor humidity that may result in severe condensation in the heat exchanger during cooling operation.

Minimum mixed air temperature (heating) (RGV units only)

Using the factory settings, the minimum temperatures for the mixed air (the combined temperature of the warm return air and the cold outdoor air) entering the dimpled, gas heat exchangers are shown in the following table.

MINIMUM TEMPERATURE FOR MIXED AIR TEMPERATURE

ALUMINIZED	STAINLESS STEEL
50°F (10°C) Continuous	40°F (4°C) Continuous
45°F (7°C) Intermittent	35°F (2°C) Intermittent

Operating at lower mixed-air temperatures may be possible, if a field-supplied, outdoor air thermostat initiates both heat stages when the temperature is less than the minimum temperatures listed above. Please contact your local representative for assistance.

Minimum and maximum airflow (heating and cooling)

To maintain safe and reliable operation of your rooftop, operate within the heating airflow limits during heating mode and cooling airflow limits during cooling mode. Operating above the max may cause blow-off, undesired airflow

noise, or airflow related problems with the rooftop unit. Operating below the min may cause problems with coil freeze-up and unsafe heating operation. Heating and cooling limitations differ when evaluating operating cfm, the minimum value is the HIGHER of the cooling and heating minimum cfm values published on page 6 and the maximum value is the LOWER of the cooling and heating maximum values published on page 6.

Heating-to-cooling changeover

Your unit will automatically change from heating to cooling mode when using a thermostat with an auto-changeover feature.

Airflow

All units are draw-through in cooling mode and blow-through in heating mode.

Outdoor air application strategies

Economizers reduce operating expenses and compressor run time by providing a free source of cooling and a means of ventilation to match application changing needs. In fact, they should be considered for most applications. Also, consider the various economizer control methods and their benefits, as well as sensors required to accomplish your application goals. Please contact your local representative for assistance.

Motor limits, break horsepower (bhp)

Due to internal design of RGV/RAV units, the air path, and specially designed motors, the full horsepower (maximum continuous bhp) band, as listed in the Fan Performance tables, can be used with the utmost confidence. There is no need for extra safety factors, as RGV/RAV motors are designed and rigorously tested to use the entire, listed bhp range without either nuisance tripping or premature motor failure.

Propane heating (RGV units only)

Propane has different physical qualities than natural gas. As a result, propane requires different fuel to air mixture. To optimize the fuel/air mixture for propane, we sell different burner orifices in an easy to install accessory kit. To select the correct burner orifices or determine the heat capacity for a propane application, use either the selection software, or the unit's service manual.

High altitude heating

High altitudes have less oxygen, which affects the fuel/air mixture in heat exchangers. In order to maintain a proper fuel/air mixture, heat exchangers operating in altitudes above 2000 ft (610 m) require different orifices. To select the correct burner orifices or determine the heat capacity for a high altitude application, use either the selection software, or the unit's service manual.

High altitudes have less oxygen, which means heat exchangers need less fuel. The new gas orifices in this field-installed kit make the necessary adjustment for high altitude applications. They restore the optimal fuel to air mixture and maintain healthy combustion on altitudes above 2000 ft (610 m).

Application data (cont)

NOTE: Typical natural gas heating value ranges from 975 to 1050 Btu/ft³ at sea level nationally. The heating value goes down approximately 1.7% per every thousand feet elevation. Standard factory orifices can typically be used up to 2000 ft (610 m) elevation without any operational issues.

Sizing a rooftop

Bigger is not necessarily better. While an air conditioner needs to have enough capacity to meet the design loads, it does not need excess capacity. In fact, excess capacity typically results in very poor part load performance and humidity control.

Using higher design temperatures than ASHRAE recommends for your location, adding “safety factors” to the calculated load, are all signs of oversizing air conditioners. Oversizing the air conditioner leads to poor humidity control, reduced efficiency, higher utility bills, larger indoor temperature swings, excessive noise, and increased wear and tear on the air conditioner.

Rather than oversizing an air conditioner, engineers should “right-size” or even slightly “under-size” air conditioners. Correctly sizing an air conditioner controls humidity better; promotes efficiency; reduces utility bills; extends equipment life, and maintains even, comfortable temperatures. Please contact your local representative for assistance.

Low ambient applications

The optional economizer can adequately cool your space by bringing in fresh, cool outside air. In fact, when so equipped, accessory low-ambient kit may not be necessary. In low ambient conditions, unless the outdoor air is excessively humid or contaminated, economizer-based “free cooling” is the preferred less costly and energy conscious method. In low ambient applications where outside air might not be desired (such as contaminated or excessively humid outdoor environments), your RGV/RAV rooftop can operate to ambient temperatures down to 0°F (–18°C) using the recommended accessory low ambient controller.

NOTE: 0°F (–18°C) is standard on size 150 models.

Guide specifications

Note about this specification:

This specification is in the "Masterformat" as published by the Construction Specification Institute. Please feel free to copy this specification directly into your building spec.

Gas Heat/Electric Cooling Packaged Rooftop

HVAC Guide Specifications

Size Range: **7.5 to 15 Nominal Tons**

Model Number: **RGV090-180**

Part 1 — (23 06 80) Schedules for Decentralized HVAC Equipment

1.01 (23 06 80.13) Decentralized Unitary HVAC Equipment Schedule

- A. (23 06 80.13.A.) Rooftop unit (RTU) schedule:
1. Schedule is per the project specification requirements.

Part 2 — (23 07 16) HVAC equipment insulation

2.01 (23 07 16.13) Decentralized, Rooftop Units:

- A. (23 07 16.13.A.) Evaporator fan compartment:
1. Interior cabinet surfaces shall be insulated with a minimum 1/2 in. thick, minimum 1 1/2 lb density, flexible fiberglass insulation bonded with a phenolic binder, neoprene coated on the air side.
 2. Insulation and adhesive shall meet NFPA 90A requirements for flame spread and smoke generation.
- B. (23 07 16.13.B.) Gas Heat Compartment:
1. Aluminum foil-faced fiberglass insulation shall be used.
 2. Insulation and adhesive shall meet NFPA 90A requirements for flame spread and smoke generation.

Part 3 — (23 09 13) Instrumentation and control devices for HVAC

3.01 (23 09 13.23) Sensors and Transmitters

- A. (23 09 13.23.A.) Thermostats
1. Thermostat must
 - a. energize both "W" and "G" when calling for heat.
 - b. have capability to energize 1 or 2 stages of cooling, and 2 different stages of heating.
 - c. include capability for occupancy scheduling.

Part 4 — (23 09 33) Electric and Electronic Control System for HVAC

4.01 (23 09 33.13) Decentralized, Rooftop Units:

- A. (23 09 33.13.A.) General:
1. Shall be complete with self-contained low-voltage control circuit protected by a resettable circuit breaker on the 24-v transformer side. Transformer shall have 75VA capability.
 2. Shall utilize color-coded wiring.

3. Shall include a Unit Control Board to conveniently and safely provide connection points for vital control functions such as: smoke detectors, phase monitor, gas controller, economizer, thermostat, and low and high pressure switches. Controller shall also provide an intuitive means to adjust the indoor fan speed through a simple switch and pot adjustment design.

4. The heat exchanger shall be controlled by an integrated gas controller (IGC) microprocessor. See heat exchanger section of this specification.

5. Unit shall include a minimum of one 8-pin screw terminal connection board for connection of control wiring.

B. (23 09 33.13.B.) Safeties:

1. Compressor over-temperature, over-current. High internal pressure differential.

2. Low pressure switch.

- a. Low pressure switch shall use different color wire than the high pressure switch. The purpose is to assist the installer and service technician to correctly wire and or troubleshoot the rooftop unit.

3. High pressure switch.

- a. High pressure switch shall use different color wire than the low pressure switch. The purpose is to assist the installer and service technician to correctly wire and or troubleshoot the rooftop unit.

4. Mixed air auto re-set temperature switch.

- a. When return air temperatures get the critical point that can cause compressor reliability issues, this switch will shut down compression only until the temperature raise accordingly. Switch opens at 60°F (16°C) and closes at 65°F (18°C).

5. Automatic reset, motor thermal overload protector.

6. Heating section shall be provided with the following minimum protections:

- a. High temperature limit switches.
- b. Induced draft motor speed sensor.
- c. Flame rollout switch.
- d. Flame proving controls.

Part 5 — (23 09 93) Sequence of Operations for HVAC Controls

5.01 (23 09 93.13) Decentralized, Rooftop Units:

- A. (23 09 93.13.A.) INSERT SEQUENCE OF OPERATION

Part 6 — (23 40 13) Panel Air Filters

6.01 (23 40 13.13) Decentralized, Rooftop Units:

- A. (23 40 13.13.A.) Standard filter section:

1. Shall consist of factory installed, low velocity, disposable 2 in. thick fiberglass filters of commercially available sizes.

Guide specifications (cont)

2. Unit shall use only one filter size. Multiple sizes are not acceptable.
3. Filters shall be accessible through an access panel with “no-tool” removal as described in the unit cabinet section of this specification (23 81 19.13.G).

Part 7 — (23 81 19) Self-Contained Air Conditioners

7.01 (23 81 19.13) Small-Capacity Self-Contained Air Conditioners:

A. (23 81 19.13.A.) General:

1. Outdoor, rooftop mounted, electrically controlled, heating and cooling unit utilizing a fully hermetic scroll compressors for cooling duty and gas combustion for heating duty.
2. Factory assembled, single-piece heating and cooling rooftop unit. Contained within the unit enclosure shall be all factory wiring, piping, controls, and special features required prior to field start-up.
3. Unit shall use R-410A refrigerant.
4. Unit shall be installed in accordance with the manufacturer’s instructions.
5. Unit must be selected and installed in compliance with local, state, and federal codes.

B. (23 81 19.13.B.) Quality Assurance:

1. Unit meets ASHRAE 90.1 minimum efficiency requirements.
2. Unit shall be rated in accordance with AHRI Standards 340/360.
3. Unit shall be designed to conform to ASHRAE 15.
4. Unit shall be UL-tested and certified in accordance with ANSI Z21.47 Standards and UL-listed and certified under Canadian standards as a total package for safety requirements.
5. Insulation and adhesive shall meet NFPA 90A requirements for flame spread and smoke generation.
6. Unit casing shall be capable of withstanding 500 hour salt spray exposure per ASTM B117 (scribed specimen).
7. Unit shall be designed in accordance with ISO 9001, and shall be manufactured in a facility registered by ISO 9001:2015.
8. Roof curb shall be designed to conform to NRCA Standards.
9. Unit shall be subjected to a completely automated run test on the assembly line. The data for each unit will be stored at the factory and must be available upon request.
10. Unit shall be designed in accordance with UL Standard 60335-2-40, including tested to withstand rain.
11. Unit shall be constructed to prevent intrusion of snow and tested to prevent snow intrusion into the control box up to 40 mph.

12. Unit shake tested to assurance level 1, ASTM D4169 to ensure shipping reliability.

C. (23 81 19.13.C.) Delivery, Storage, and Handling:

1. Unit shall be stored and handled per manufacturer’s recommendations.
2. Lifted by crane requires either shipping top panel or spreader bars.
3. Unit shall only be stored or positioned in the upright position.

D. (23 81 19.13.D.) Project Conditions:

1. As specified in the contract.

E. (23 81 19.13.E.) Operating Characteristics:

1. Unit shall be capable of starting and running at 125°F (52°C) ambient outdoor temperature except 14 size models that are capable of starting and running at 120°F (49°C), meeting maximum load criteria of AHRI Standard 210/240 or 340/360 at ±10% voltage.
2. Compressor with standard controls shall be capable of operation down to 40°F (4°C) [0°F (–18°C) for size 14 models], ambient outdoor temperatures. Accessory winter start kit is necessary if mechanically cooling at ambient temperatures down to 25°F (–4°C) or 0°F (–18°C).
3. Unit shall discharge supply air vertically or horizontally as shown on contract drawings.
4. Unit shall be factory configured for vertical supply and return configurations.
5. Unit shall be field convertible from vertical to horizontal airflow on all models. No special kit required except on 180 size models that require a Supply Duct Kit field installed for horizontal airflow.
6. Unit shall be capable of mixed operation: vertical supply with horizontal return or horizontal supply with vertical return.

F. (23 81 19.13.F.) Electrical Requirements:

1. Main power supply voltage, phase, and frequency must match those required by the manufacturer.

G. (23 81 19.13.G.) Unit Cabinet:

1. Unit cabinet shall be constructed of galvanized steel, and shall be bonderized and coated with a prepainted baked enamel finish on all externally exposed surfaces.
2. Unit cabinet exterior paint shall be: film thickness, (dry) 0.003 inches minimum, gloss (per ASTM D523, 60°F/16°C): 60, Hardness: H-2H Pencil hardness.
3. Evaporator fan compartment interior cabinet insulation shall conform to AHRI Standards 340/360 minimum exterior sweat criteria. Interior surfaces shall be insulated with a minimum 1/2 in. thick, 1 lb density, flexible fiberglass insulation, neoprene coated on the air side.

Guide specifications (cont)

- Aluminum foil-faced fiberglass insulation shall be used in the gas heat compartment.
4. Base of unit shall have a minimum of four locations for thru-the-base gas and electrical connections (factory-installed or field-installed), standard.
 5. Base Rail:
 - a. Unit shall have base rails on a minimum of 2 sides.
 - b. Holes shall be provided in the base rails for rigging shackles to facilitate maneuvering and overhead rigging.
 - c. Holes shall be provided in the base rail for moving the rooftop by fork truck.
 - d. Base rail shall be a minimum of 16 gauge thickness.
 6. Condensate pan and connections:
 - a. Shall be a sloped condensate drain pan made of a corrosion resistant material.
 - b. Shall comply with ASHRAE Standard 62.
 - c. Shall use a 3/4 in. 14 NPT drain connection, possible either through the bottom or side of the drain pan. Connection shall be made per manufacturer's recommendations.
 7. Top panel:
 - a. Shall be a single piece top panel on 090-150 model and two piece on 180 size models.
 8. Gas Connections:
 - a. All gas piping connecting to unit gas valve shall enter the unit cabinet at a single location on side of unit (horizontal plane).
 - b. Thru-the-base capability.
 - 1) Standard unit shall have a thru-the-base gas-line location using a raised, embossed portion of the unit basepan.
 - 2) Optional, factory approved, water-tight connection method must be used for thru-the-base gas connections.
 - 3) No basepan penetration, other than those authorized by the manufacturer, is permitted.
 9. Electrical Connections:
 - a. All unit power wiring shall enter unit cabinet at a single, factory prepared, knockout location.
 - b. Thru-the-base capability.
 - 1) Standard unit shall have a thru-the-base electrical location(s) using a raised, embossed portion of the unit basepan.
 - 2) Optional, factory approved, water-tight connection method must be used for thru-the-base electrical connections.
 - 3) No basepan penetration, other than those authorized by the manufacturer, is permitted.
 10. Component access panels (standard):
 - a. Cabinet panels shall be easily removable for servicing.
 - b. Unit shall have one factory installed, tool-less, removable, filter access panel.
 - c. Panels covering control box, indoor fan, indoor fan motor, gas components (where applicable), and compressors shall have molded composite handles.
 - d. Handles shall be UV modified, composite. They shall be permanently attached, and recessed into the panel.
 - e. Screws on the vertical portion of all removable access panel shall engage into heat resistant, molded composite collars.
 - f. Collars shall be removable and easily replaceable using manufacturer recommended parts.
- H. (23 81 19.13.H.) Gas Heat:
1. General:
 - a. Heat exchanger shall be an induced draft design. Positive pressure heat exchanger designs shall not be allowed.
 - b. Shall incorporate a direct-spark ignition system and redundant main gas valve.
 - c. Gas supply pressure at the inlet to the rooftop unit gas valve must match that required by the manufacturer.
 2. The heat exchanger shall be controlled by an integrated gas controller (IGC) microprocessor.
 - a. IGC board shall notify users of fault using an LED (light-emitting diode).
 - b. The LED shall be visible without removing the control box access panel.
 - c. IGC board shall contain algorithms that modify evaporator fan operation to prevent future cycling on high temperature limit switch.
 - d. Unit shall be equipped with anti-cycle protection with one short cycle on unit flame rollout switch or 4 continuous short cycles on the high temperature limit switch. Fault indication shall be made using an LED.
 3. Standard Heat Exchanger construction:
 - a. Heat exchanger shall be of the tubular-section type constructed of a minimum of 20-gauge steel coated with a nominal 1.2 mil aluminum-silicone alloy for corrosion resistance.
 - b. Burners shall be of the in-shot type constructed of aluminum-coated steel.
 - c. Burners shall incorporate orifices for rated heat output up to 2000 ft (610 m) elevation. Additional accessory kits may be required for applications above 2000 ft (610 m)

Guide specifications (cont)

- elevation, depending on local gas supply conditions.
- d. Each heat exchanger tube shall contain multiple dimples for increased heating effectiveness.
- 4. Optional Stainless Steel Heat Exchanger construction:
 - a. Use energy saving, direct-spark ignition system.
 - b. Use a redundant main gas valve.
 - c. Burners shall be of the in-shot type constructed of aluminum-coated steel.
 - d. All gas piping shall enter the unit cabinet at a single location on side of unit (horizontal plane).
 - e. The optional stainless steel heat exchanger shall be of the tubular-section type, constructed of a minimum of 20-gauge type 409 stainless steel.
 - f. Type 409 stainless steel shall be used in heat exchanger tubes and vestibule plate.
 - g. Complete stainless steel heat exchanger allows for greater application flexibility.
- 5. Induced draft combustion motor and blower:
 - a. Shall be a direct-drive, single inlet, forward-curved centrifugal type.
 - b. Shall be made from steel with a corrosion resistant finish.
 - c. Shall have permanently lubricated sealed bearings.
 - d. Shall have inherent thermal overload protection.
 - e. Shall have an automatic reset feature.
- I. (23 81 19.13.I.) Coils:
 - 1. Standard Aluminum Fin-Copper Tube Coils:
 - a. Standard evaporator and condenser coils shall have aluminum lanced plate fins mechanically bonded to seamless internally grooved copper tubes with all joints brazed.
 - b. Evaporator coils shall be leak tested to 150 psig, pressure tested to 450 psig, and qualified to UL 1995 burst test at 1775 psig.
 - c. Condenser coils shall be leak tested to 150 psig, pressure tested to 650 psig, and qualified to UL 1995 burst test at 1980 psig.
 - 2. Optional Pre-coated aluminum-fin condenser coils:
 - a. Shall have a durable epoxy-phenolic coating to provide protection in mildly corrosive coastal environments.
 - b. Coating shall be applied to the aluminum fin stock prior to the fin stamping process to create an inert barrier between the aluminum fin and copper tube.
 - c. Epoxy-phenolic barrier shall minimize galvanic action between dissimilar metals.
 - d. Corrosion durability of fin stock shall be confirmed through testing to be no less than 1000 hours salt spray per ASTM B117-90.
 - e. Corrosion durability of fin stock shall be confirmed through testing to have no visible corrosion after 48 hour immersion in a room temperature solution of 5% salt, 1% acetic acid.
 - f. Fin stock coating shall pass 2000 hours of the following: one week exposure in the prohesion chamber followed by one week of accelerated ultraviolet light testing. Prohesion chamber: the solution shall contain 3.5% sodium chloride and 0.35% ammonium sulfate. The exposure cycle is one hour of salt fog application at ambient followed by one hour drying at 95°F (35°C).
 - 3. Optional Copper-fin evaporator and condenser coils:
 - a. Shall be constructed of copper fins mechanically bonded to copper tubes and copper tube sheets.
 - b. Galvanized steel tube sheets shall not be acceptable.
 - c. A polymer strip shall prevent coil assembly from contacting the sheet metal coil pan to minimize potential for galvanic corrosion between coil and pan.
 - 4. Optional E-coated aluminum-fin evaporator and condenser coils:
 - a. Shall have a flexible epoxy polymer coating uniformly applied to all coil surface areas without material bridging between fins.
 - b. Coating process shall ensure complete coil encapsulation of tubes, fins and headers.
 - c. Color shall be high gloss black with gloss per ASTM D523-89.
 - d. Uniform dry film thickness from 0.8 to 1.2 mil on all surface areas including fin edges.
 - e. Superior hardness characteristics of 2H per ASTM D3363-92A and cross-hatch adhesion of 4B-5B per ASTM D3359-93.
 - f. Impact resistance shall be up to 160 in. lb (ASTM D2794-93).
 - g. Humidity and water immersion resistance shall be up to minimum 1000 and 250 hours respectively (ASTM D2247-92 and ASTM D870-92).
 - h. Corrosion durability shall be confirmed through testing to be no less than 1000 hours salt spray per ASTM B117-90.

Guide specifications (cont)

J. (23 81 19.13.J.) Refrigerant Components:

1. Refrigerant circuit shall include the following control, safety, and maintenance features:

- a. Thermostatic Expansion Valve (TXV) shall help provide optimum performance across the entire operating range. Shall contain removable power element to allow change out of power element and bulb without removing the valve body.
- b. Refrigerant filter drier — Solid core design.
- c. Service gauge connections on suction and discharge lines.
- d. Pressure gauge access through a specially designed access port in the top panel of the unit.

2. Compressors:

- a. Unit shall use two tandem scroll compressors on single independent refrigeration circuit.
- b. Units shall have single circuit and two-stage cooling and contain two dual stage compressors.
- c. Evaporator coils shall be a full active design to help better control comfort latent removal.
- d. Compressor motors shall be cooled by refrigerant gas passing through motor windings.
- e. Compressors shall be internally protected from high discharge temperature conditions.
- f. Compressors shall be protected from an over-temperature and over-ampereage conditions by an internal, motor overload device.
- g. Compressor shall be factory-mounted on rubber grommets.
- h. Compressor motors shall have internal line break thermal, current overload and high pressure differential protection.
- i. Crankcase heaters shall not be required for normal operating range, unless required by the manufacturer due to refrigerant charge limits.

K. (23 81 19.13.K.) Return Air Filter Section:

1. Filters access is specified in the unit cabinet section of this specification.
2. Filters shall be held in place by a pivoting filter tray, facilitating easy removal and installation.
3. Shall consist of factory installed, low velocity, throw-away 2 in. thick fiberglass filters.
4. Filters shall be standard, commercially available sizes.
5. Only one size filter per unit is allowed.

L. (23 81 19.13.L.) Evaporator Fan and Motor with X-Vane™ Fan Technology:

1. Direct Drive Evaporator fan motor:
 - a. Shall be a ECM motor design.

- b. Shall have permanently lubricated bearings.
- c. Shall have inherent automatic-reset thermal overload protection.
- d. Shall have slow ramp up to speed capabilities.
- e. Shall require no fan/motor belts for operation, adjustments and or initial fan speed set up.
- f. Fan DC voltage set up on Unit Control Board can eliminate the need of removal of blower access door, required on conventional belt drive systems.
- g. Shall be internally protected from electrical phase reversal and loss.

2. Evaporator Fan:

- a. Shall be easily set with dedicated selection switch and adjustment pot on unit control board.
- b. Shall provide two-stage cooling capacity control, the indoor fan speed is automatically controlled to meet the code-compliant <66% low fan speed and 100% at full fan speed operation.
- c. Blower fan shall be a Vane Axial fan design with 75% less moving parts than a conventional belt drive system.
- d. Shall be constructed of a cast aluminum stator and high impact composite material on stator, rotor and air inlet casing.
- e. Shall be a patented design with a corrosion resistant material and dynamically balanced.
- f. Shall have slow ramp up to speed capabilities to help reduce sound and comfort issues typically associated with single speed belt drive systems.
- g. Shall be a slide out design with removal of a few support brackets.

3. Shall include an easily accessible Unit Control Board to conveniently and safely provide connection points for vital control functions such as: smoke detectors, phase monitor, gas controller, economizer, thermostat, and low, high and mixed air temperature switches. Controller shall also provide an intuitive means to adjust the indoor fan speed through a simple switch and pot adjustment design.

M. (23 81 19.13.M.) Condenser Fans and Motors:

1. Condenser fan motors:
 - a. Shall be a totally enclosed motor.
 - b. Shall use permanently lubricated bearings.
 - c. Shall have inherent thermal overload protection with an automatic reset feature.
 - d. Shall use a shaft-down design on all sizes.
2. Condenser Fans:
 - a. Shall be a direct-driven propeller type fan.

Guide specifications (cont)

- b. Shall have galvalum blades riveted to steel spider that have corrosion-resistant properties and shall be dynamically balanced.
- N. (23 81 19.13.N.) Special Features Options and Accessories:
- 1. Integrated EconoMiSer® X Low Leak rate models.
 - a. Integrated, gear driven opposing modulating blade design type capable of simultaneous economizer and compressor operation.
 - b. Independent modules for vertical or horizontal return configuration shall be available. Vertical return modules shall be available as a factory installed option.
 - c. Damper blades shall be galvanized steel with composite gears. Plastic or composite blades on intake or return shall not be acceptable.
 - d. Shall include all hardware and controls to provide free cooling with outdoor air when temperature and/or humidity are below setpoints.
 - e. Shall be equipped with gear driven dampers for both the outdoor ventilation air and the return air for positive air stream control.
 - f. Standard leak rate shall be equipped with dampers not to exceed 2% leakage at 1 in. wg pressure differential.
 - g. Economizer controller on EconoMiSer X models shall be the Honeywell W7220 that provides:
 - 1) 2-line LCD interface screen for setup, configuration and troubleshooting.
 - 2) On-board Fault Detection and Diagnostics (FDD) that senses and alerts when the economizer is not operating properly, per California Title 24, ASHRAE 90.1 and IECC¹.
 - 3) Sensor failure loss of communication identification.
 - 4) Automatic sensor detection.
 - 5) Capabilities for use with multiple-speed or single speed indoor fan systems.
 - 6) Utilize digital sensors: Dry bulb and Enthalpy.
 - h. Shall be capable of introducing up to 100% outdoor air.
 - i. Shall be equipped with a barometric relief damper capable of relieving up to 100% return air and contain seals that meet ASHRAE 90.1 requirements.
 - j. Shall be designed to close damper(s) during loss-of-power situations with spring return built into motor.
 - k. Dry bulb outdoor air temperature sensor shall be provided as standard. Enthalpy sensor is also available on factory-installed economizers only. Outdoor air sensor setpoint shall be adjustable and shall range from 40°F to 100°F (4°C to 38°C). Additional sensor options shall be available as accessories.
 - l. The economizer controller shall also provide control of an accessory power exhaust unit function. Factory set at 100%, with a range of 0% to 100%.
 - m. The economizer shall maintain minimum airflow into the building during occupied period and provide design ventilation rate for full occupancy.
 - n. Dampers shall be completely closed when the unit is in the unoccupied mode.
 - o. Economizer controller shall accept a 2 to 10 Vdc CO₂ sensor input for IAQ/DCV control. In this mode, dampers shall modulate the outdoor air damper to provide ventilation based on the sensor input.
 - p. Compressor lockout temperature on W7220 control is adjustable from -45°F to 80°F (-43°C to 27°C), set at a factory default of 32°F (0°C). W7212 control opens at 35°F (2°C) and closes at 50°F (10°C).
 - q. Actuator shall be direct coupled to economizer gear. No linkage arms or control rods shall be acceptable.
 - r. Economizer controller shall provide indications when in free cooling mode, in the DCV mode, or the exhaust fan contact is closed.
- 2. Integrated EconoMiSer X Ultra Low Leak rate models.
 - a. Integrated, gear driven opposing modulating blade design type capable of simultaneous economizer and compressor operation.
 - b. Independent modules for vertical or horizontal return configuration shall be available. Vertical return modules shall be available as a factory installed option.
 - c. Damper blades shall be galvanized steel with composite gears. Plastic or composite blades on intake or return shall not be acceptable.
 - d. Shall include all hardware and controls to provide free cooling with outdoor air when temperature and/or humidity are below setpoints.
 - e. Shall be equipped with gear driven dampers for both the outdoor ventilation air and the return air for positive air stream control.
 - f. Ultra Low Leak design meets California Title 24 section 140.4 and ASHRAE 90.1 requirements for 4 cfm per sq ft on the

1. IECC is a registered trademark of the International Code Council, Inc.

Guide specifications (cont)

- outside air dampers and 10 cfm per sq ft on the return dampers.
- g. Economizer controller on EconoMi\$er X models shall be the Honeywell W7220 that provides:
 - 1) 2-line LCD interface screen for setup, configuration and troubleshooting.
 - 2) On-board Fault Detection and Diagnostics (FDD) that senses and alerts when the economizer is not operating properly, per California Title 24, ASHRAE 90.1 and IECC.
 - 3) Sensor failure loss of communication identification.
 - 4) Automatic sensor detection.
 - 5) Capabilities for use with multiple-speed indoor fan systems.
 - 6) Utilize digital sensors: Dry bulb and Enthalpy.
 - h. Shall be capable of introducing up to 100% outdoor air.
 - i. Shall be equipped with a barometric relief damper capable of relieving up to 100% return air and contain seals that meet ASHRAE 90.1 requirements.
 - j. Shall be designed to close damper(s) during loss-of-power situations with spring return built into motor.
 - k. Dry bulb outdoor air temperature sensor shall be provided as standard. Enthalpy sensor is also available on factory-installed economizers only. Outdoor air sensor setpoint shall be adjustable and shall range from 40°F to 100°F (4°C to 38°C). Additional sensor options shall be available as accessories.
 - l. The economizer controller shall also provide control of an accessory power exhaust unit function. Factory set at 100%, with a range of 0% to 100%.
 - m. The economizer shall maintain minimum airflow into the building during occupied period and provide design ventilation rate for full occupancy.
 - n. Dampers shall be completely closed when the unit is in the unoccupied mode.
 - o. Economizer controller shall accept a 2 to 10 vdc CO₂ sensor input for IAQ/DCV control. In this mode, dampers shall modulate the outdoor air damper to provide ventilation based on the sensor input.
 - p. Compressor lockout temperature on W7220 control is adjustable from -45°F to 80°F (-43°C to 27°C), set at a factory default of 32°F (0°C).
 - q. Actuator shall be direct coupled to economizer gear. No linkage arms or control rods shall be acceptable.
 - r. Economizer controller shall provide indications when in free cooling mode, in the DCV mode, or the exhaust fan contact is closed.
- 3. Two-Position Damper (Field-installed only):
 - a. Damper shall be a Two-Position Damper. Damper travel shall be from the full closed position to the field adjustable %-open setpoint.
 - b. Damper shall include adjustable damper travel from 25% to 100% (full open).
 - c. Damper shall include single or dual blade, gear driven dampers and actuator motor.
 - d. Actuator shall be direct coupled to damper gear. No linkage arms or control rods shall be acceptable.
 - e. Damper will admit up to 100% outdoor air for applicable rooftop units.
 - f. Damper shall close upon indoor (evaporator) fan shutoff and/or loss of power.
 - g. The damper actuator shall plug into the rooftop unit's wiring harness plug. No hard wiring shall be required.
 - h. Outside air hood shall include aluminum water entrainment filter.
 - 4. Manual damper (Field-installed only):
 - a. Manual damper package shall consist of damper, air inlet screen, and rain hood which can be preset to admit up to 25 or 50% outdoor air for year round ventilation.
 - 5. Hot Gas Re-Heat Dehumidification System:
 - a. The Hot Gas Re-Heat Dehumidification System shall be factory installed and shall provide greater dehumidification of the occupied space by two modes of dehumidification operations in addition to its normal design cooling mode:
 - 1) Subcooling mode further sub cools the hot liquid refrigerant leaving the condenser coil when both temperature and humidity in the space are not satisfied.
 - 2) Hot gas reheat mode shall mix a portion of the hot gas from the discharge of the compressor with the hot liquid refrigerant leaving the condenser coil to create a two-phase heat transfer in the system, resulting in a neutral leaving air temperature when only humidity in the space is not satisfied.
 - 3) Includes low ambient controller.
 - 6. Low Ambient Control Package:
 - a. Controller shall control coil head pressure by condenser fan speed modulation or condenser fan cycling and wind baffles.
 - b. Shall consist of solid-state control and condenser coil temperature sensor to maintain

Guide specifications (cont)

- condensing temperature between 90°F (32°C) and 110°F (43°C) at outdoor ambient temperatures down to 0°F (-18°C).
7. Propane Gas Conversion Kit:
 - a. Package shall contain all the necessary hardware and instructions to convert a standard natural gas unit for use with liquefied propane, up to 2000 ft (610 m) elevation.
 - b. Additional accessory kits may be required for applications above 2000 ft (610 m) elevation.
 8. Flue Shield (090-150 sizes only):
 - a. Flue shield shall provide protection from the hot sides of the gas flue hood.
 9. Condenser Coil Hail Guard Assembly:
 - a. Shall protect against damage from hail.
 - b. Shall be either hood style or louvered.
 10. Unit-Mounted, Non-Fused Disconnect Switch (Available on 7.5 to 12.5 ton units with MOCPS of 80 amps or less, or 15 ton units with MOCPS of 100 amps or less):
 - a. Switch shall be factory installed, internally mounted.
 - b. National Electric Code (NEC) and UL approved non-fused switch shall provide unit power shutoff.
 - c. Shall be accessible from outside the unit.
 - d. Shall provide local shutdown and lockout capability.
 - e. Sized only for the unit as ordered from the factory. Does not accommodate field-installed devices.
 11. Convenience Outlet:
 - a. Powered convenience outlet.
 - 1) Outlet shall be powered from main line power to the rooftop unit.
 - 2) Outlet shall be powered from line side or load side of disconnect by installing contractor, as required by code. If outlet is powered from load side of disconnect, unit electrical ratings shall be UL certified and rated for additional outlet amperage.
 - 3) Outlet shall be factory-installed and internally mounted with easily accessible 115-v female receptacle.
 - 4) Outlet shall include 15 amp GFI receptacles with independent fuse protection.
 - 5) Voltage required to operate convenience outlet shall be provided by a factory installed step-down transformer.
 - 6) Outlet shall be accessible from outside the unit.
 - 7) Outlet shall include a field installed "Wet in Use" cover.
 - b. Factory-Installed Non-Powered convenience outlet.
 - 1) Outlet shall be powered from a separate 115/120v power source.
 - 2) A transformer shall not be included.
 - 3) Outlet shall be factory-installed and internally mounted with easily accessible 115-v female receptacle.
 - 4) Outlet shall include 15 amp GFI receptacles with independent fuse protection.
 - 5) Outlet shall be accessible from outside the unit.
 - 6) Outlet shall include a field installed "Wet in Use" cover.
 - c. Field-Installed Non-Powered convenience outlet.
 - 1) Outlet shall be powered from a separate 115/120v power source.
 - 2) A transformer shall not be included.
 - 3) Outlet shall be field-installed and internally mounted with easily accessible 115-v female receptacle.
 - 4) Outlet shall include 20 amp GFI receptacles. This kit provides a flexible installation method which allows code compliance for height requirements of the GFCI outlet from the finished roof surface as well as the capability to relocate the outlet to a more convenient location.
 - 5) Outlet shall be accessible from outside the unit.
 - 6) Outlet shall include a field installed "Wet in Use" cover.
 12. Flue Discharge Deflector:
 - a. Flue discharge deflector shall direct unit exhaust vertically instead of horizontally.
 - b. Deflector shall be defined as a "natural draft" device by the National Fuel and Gas (NFG) code.
 13. Thru-the-Base Connectors:
 - a. Kits shall provide connectors to permit gas and electrical connections to be brought to the unit through the unit basepan.
 - b. Minimum of four connection locations per unit.
 14. Supply Duct Cover (size 180 only):
 - a. Required when field converting the factory standard vertical duct supply to horizontal duct supply configuration. One required per unit.
 15. Propeller Power Exhaust:
 - a. Power exhaust shall be used in conjunction with an integrated economizer.

Guide specifications (cont)

- b. Independent modules for vertical or horizontal return configurations shall be available.
 - c. Horizontal power exhaust is shall be mounted in return ductwork.
 - d. Power exhaust shall be controlled by economizer controller operation. Exhaust fans shall be energized when dampers open past the 0 to 100% adjustable setpoint on the economizer control.
16. Roof Curbs (Vertical):
- a. Full perimeter roof curb with exhaust capability providing separate air streams for energy recovery from the exhaust air without supply air contamination.
 - b. Formed galvanized steel with wood nailer strip and shall be capable of supporting entire unit weight.
 - c. Permits installation and securing of ductwork to curb prior to mounting unit on the curb.
17. High Altitude Gas Conversion Kit:
- a. Package shall contain all the necessary hardware and instructions to convert a standard natural gas unit to operate from 2000 to 7000 ft (610 to 2134 m) elevation with natural gas or from 0 to 7000 ft (0 to 2134 m) elevation with liquefied propane.
18. Outdoor Air Enthalpy Sensor:
- a. The outdoor air enthalpy sensor shall be used to provide single enthalpy control. When used in conjunction with a return air enthalpy sensor, the unit will provide differential enthalpy control. The sensor allows the unit to determine if outside air is suitable for free cooling.
19. Return Air Enthalpy Sensor:
- a. The return air enthalpy sensor shall be used in conjunction with an outdoor air enthalpy sensor to provide differential enthalpy control.
20. Indoor Air Quality (CO₂) Sensor:
- a. Shall be able to provide demand ventilation indoor air quality (IAQ) control.
 - b. The IAQ sensor shall be available in duct mount, wall mount, or wall mount with LED display. The setpoint shall have adjustment capability.
21. Smoke detectors (factory-installed only):
- a. Shall be a Four-Wire Controller and Detector.
 - b. Shall be environmental compensated with differential sensing for reliable, stable, and drift-free sensitivity.
 - c. Shall use magnet-activated test/reset sensor switches.
- d. Shall have tool-less connection terminal access.
 - e. Shall have a recessed momentary switch for testing and resetting the detector.
 - f. Controller shall include:
 - 1) One set of normally open alarm initiation contacts for connection to an initiating device circuit on a fire alarm control panel.
 - 2) Two Form-C auxiliary alarm relays for interface with rooftop unit or other equipment.
 - 3) One Form-C supervision (trouble) relay to control the operation of the Trouble LED on a remote test/reset station.
 - 4) Capable of direct connection to two individual detector modules.
 - 5) Can be wired to up to 14 other duct smoke detectors for multiple fan shut-down applications.
22. Winter Start Kit:
- a. Shall contain a bypass device around the low pressure switch.
 - b. Shall be required when mechanical cooling is required down to 25°F (−4°C).
 - c. Shall not be required to operate on an economizer when below an outdoor ambient of 40°F (4°C).
23. Time Guard:
- a. Shall prevent compressor short-cycling by providing a 5-minute delay (±2 minutes) before restarting a compressor after shut-down for any reason.
 - b. One device shall be required per compressor.
24. Disconnect Switch Bracket (size 180 only):
- a. Provides a pre-engineered and sized mounting bracket for applications requiring a unit mounted fused and non-fused disconnect of greater than 100 amps. Bracket assures that no damage will occur to coils when mounting with screws and other fasteners.
25. Hinged Access Panels:
- a. Shall provide easy access through integrated quarter turn latches.
 - b. Shall be on major panels of: filter, control box, fan motor, and compressor.
26. Condensate Overflow switch:
- a. This sensor and related controller monitors the condensate level in the drain pan and shuts down compression operation when overflow conditions occur. It includes:
 - 1) Indicator light — solid red (more than 10 seconds on water contact —

Guide specifications (cont)

- compressors disabled), blinking red (sensor disconnected).
 - 2) 10 second delay to break — eliminates nuisance trips from splashing or waves in pan (sensor needs 10 seconds of constant water contact before tripping).
 - 3) Disables the compressors operation when condensate plug is detected, but still allows fans to run for Economizer.
27. 4 in. filter rack kit:
- a. The 4 in. filter rack accessory kit is designed to hold 4 in. MERV-8 or MERV-13 filters. Filters not included in kit.
28. 2 in. MERV-13 Return Air filters:
- a. Accessory kit to field upgrade standard unit filters to 2 in. MERV-13 filters.
29. 2 in. MERV-8 Return Air filters:
- a. Accessory kit to field upgrade standard unit filters to 2 in. MERV-8 filters.
30. Phase Monitor Control:
- a. Shall monitor the sequence of three phase electrical system to provide a phase reversal protection.
 - b. Shall monitor the three phase voltage inputs to provide a phase loss protection for the three phase device.
- c. Will work on either a Delta or Wye power connection.
31. Horn/Strobe Annunciator:
- a. Provides an audible/visual signaling device for use with factory-installed option or field installed accessory smoke detectors.
 - 1) Requires installation of a field-supplied 24-v transformer suitable for 4.2 VA (AC) or 3.0 VA (DC) per horn/strobe accessory.
 - 2) Requires field-supplied electrical box, North American 1-gang box, 2 in. (51 mm) x 4 in. (102 mm).
 - 3) Shall have a clear colored lens.
32. UV-C Ultraviolet Lamp Kit:
- a. High-output, low temperature ultraviolet lamp accessory. It includes:
 - 1) lamp, interlock switch, mounting brackets, necessary wires, wire ties, screws and labels to field install kit in unit return air plenum.
 - 2) Separate dedicated 115v power source required.
 - 3) UV-C kit can not be used on units with Hot Gas Re-Heat system.

Guide specifications (cont)

Note about this specification:

This specification is in the "Masterformat" as published by the Construction Specification Institute. Please feel free to copy this specification directly into your building spec.

Cooling Only/Electric Heat Packaged Rooftop

HVAC Guide Specifications

Size Range: **7.5 to 15 Nominal Tons**

Model Number: **RAV090-180**

Part 1 — (23 06 80) Schedules for Decentralized HVAC Equipment

1.01 (23 06 80.13) Decentralized Unitary HVAC Equipment Schedule:

- A. (23 06 80.13.A.) Rooftop unit (RTU) schedule:
1. Schedule is per the project specification requirements.

Part 2 — (23 07 16) HVAC equipment insulation

2.01 (23 07 16.13) Decentralized, Rooftop Units:

- A. (23 07 16.13.A.) Evaporator fan compartment:
1. Interior cabinet surfaces shall be insulated with a minimum 1/2 in. thick, minimum 1 1/2 lb density, flexible fiberglass insulation bonded with a phenolic binder, neoprene coated on the air side.
 2. Insulation and adhesive shall meet NFPA 90A requirements for flame spread and smoke generation.
- B. (23 07 16.13.B.) Electric Heat Compartment:
1. Aluminum foil-faced fiberglass insulation shall be used.
 2. Insulation and adhesive shall meet NFPA 90A requirements for flame spread and smoke generation.

Part 3 — (23 09 13) Instrumentation and control devices for HVAC

3.01 (23 09 13.23) Sensors and Transmitters:

- A. (23 09 13.23.A.) Thermostats:
1. Thermostat must
 - a. energize both "W" and "G" when calling for heat.
 - b. have capability to energize 1 or 2 stages of cooling, and 2 different stages of heating.
 - c. include capability for occupancy scheduling.

Part 4 — (23 09 33) Electric and Electronic Control System for HVAC

4.01 (23 09 33.13) Decentralized, Rooftop Units:

- A. (23 09 33.13.A.) General:
1. Shall be complete with self-contained low-voltage control circuit protected by a resettable circuit breaker on the 24-v transformer side. Transformer shall have 75VA capability.

2. Shall utilize color-coded wiring.
 3. Shall include a Unit Control Board to conveniently and safely provide connection points for vital control functions such as: smoke detectors, phase monitor, economizer, thermostat, and low and high pressure switches. Controller shall also provide an intuitive means to adjust the indoor fan speed through a simple switch and pot adjustment design.
 4. Unit shall include a minimum of one 8-pin screw terminal connection board for connection of control wiring.
- B. (23 09 33.13.B.) Safeties:
1. Compressor over-temperature, over-current. High internal pressure differential.
 2. Low pressure switch.
 - a. Low pressure switch shall use different color wire than the high pressure switch. The purpose is to assist the installer and service technician to correctly wire and or troubleshoot the rooftop unit.
 3. High pressure switch.
 - a. High pressure switch shall use different color wire than the low pressure switch. The purpose is to assist the installer and service technician to correctly wire and or troubleshoot the rooftop unit.
 4. Mixed air auto re-set temperature switch
 - a. When return air temperatures get the critical point that can cause compressor reliability issues, this switch will shut down compression only until the temperature raise accordingly. Switch opens at 60°F (16°C) and closes at 65°F (18°C).
 5. Automatic reset, motor thermal overload protector.

Part 5 — (23 09 93) Sequence of Operations for HVAC Controls

5.01 (23 09 93.13) Decentralized, Rooftop Units:

- A. (23 09 93.13.A.) INSERT SEQUENCE OF OPERATION

Part 6 — (23 40 13) Panel Air Filters

6.01 (23 40 13.13) Decentralized, Rooftop Units:

- A. (23 40 13.13.A.) Standard filter section:
1. Shall consist of factory installed, low velocity, disposable 2 in. thick fiberglass filters of commercially available sizes.
 2. Unit shall use only one filter size. Multiple sizes are not acceptable.
 3. Filters shall be accessible through an access panel with "no-tool" removal as described in the unit cabinet section of this specification (23 81 19.13.G).

Guide specifications (cont)

Part 7 — (23 81 19) Self-Contained Air Conditioners

7.01 (23 81 19.13) Small-Capacity Self-Contained Air Conditioners:

A. (23 81 19.13.A.) General:

1. Outdoor, rooftop mounted, electrically controlled, heating and cooling unit utilizing fully hermetic scroll compressors for cooling duty and optional electric heat for heating duty.
2. Factory assembled, single-piece heating and cooling rooftop unit. Contained within the unit enclosure shall be all factory wiring, piping, controls, and special features required prior to field start-up.
3. Unit shall use R-410A refrigerant.
4. Unit shall be installed in accordance with the manufacturer's instructions.
5. Unit must be selected and installed in compliance with local, state, and federal codes.

B. (23 81 19.13.B.) Quality Assurance:

1. Unit meets ASHRAE 90.1 minimum efficiency requirements.
2. Unit shall be rated in accordance with AHRI Standards 340/360.
3. Unit shall be designed to conform to ASHRAE 15.
4. Unit shall be UL-tested and certified in accordance with ANSI Z21.47 Standards and UL-listed and certified under Canadian standards as a total package for safety requirements.
5. Insulation and adhesive shall meet NFPA 90A requirements for flame spread and smoke generation.
6. Unit casing shall be capable of withstanding 500 hour salt spray exposure per ASTM B117 (scribed specimen).
7. Unit shall be designed in accordance with ISO 9001, and shall be manufactured in a facility registered by ISO 9001:2015.
8. Roof curb shall be designed to conform to NRCA Standards.
9. Unit shall be subjected to a completely automated run test on the assembly line. The data for each unit will be stored at the factory, and must be available upon request.
10. Unit shall be designed in accordance with UL Standard 60335-2-40, including tested to withstand rain.
11. Unit shall be constructed to prevent intrusion of snow and tested to prevent snow intrusion into the control box up to 40 mph.
12. Unit shake tested to assurance level 1, ASTM D4169 to ensure shipping reliability.

C. (23 81 19.13.C.) Delivery, Storage, and Handling:

1. Unit shall be stored and handled per manufacturer's recommendations.

2. Lifted by crane requires either shipping top panel or spreader bars.
3. Unit shall only be stored or positioned in the upright position.

D. (23 81 19.13.D.) Project Conditions:

1. As specified in the contract.

E. (23 81 19.13.E.) Operating Characteristics:

1. Unit shall be capable of starting and running at 125°F (52°C) ambient outdoor temperature except 14 size models that are capable of starting and running at 120°F (49°C), meeting maximum load criteria of AHRI Standard 340/360 at ±10% voltage.
2. Compressor with standard controls shall be capable of operation down to 40°F (4°C) [0°F (-18°C) for size 14 models], ambient outdoor temperatures. Accessory winter start kit is necessary if mechanically cooling at ambient temperatures down to 25°F (-4°C) or 0°F (-18°C).
3. Unit shall discharge supply air vertically or horizontally as shown on contract drawings.
4. Unit shall be factory configured for vertical supply and return configurations.
5. Unit shall be field convertible from vertical to horizontal airflow on all models. No special kit required except on 180 size models that requires a Supply Duct Kit field installation for horizontal airflow.
6. Unit shall be capable of mixed operation: vertical supply with horizontal return or horizontal supply with vertical return.

F. (23 81 19.13.F.) Electrical Requirements:

1. Main power supply voltage, phase, and frequency must match those required by the manufacturer.

G. (23 81 19.13.G.) Unit Cabinet:

1. Unit cabinet shall be constructed of galvanized steel, and shall be bonderized and coated with a prepainted baked enamel finish on all externally exposed surfaces.
2. Unit cabinet exterior paint shall be: film thickness, (dry) 0.003 in. minimum, gloss (per ASTM D523, 60°F/16°C): 60, Hardness: H-2H Pencil hardness.
3. Evaporator fan compartment interior cabinet insulation shall conform to AHRI Standards 340/360 minimum exterior sweat criteria. Interior surfaces shall be insulated with a minimum 1/2 in. thick, 1 lb density, flexible fiberglass insulation, neoprene coated on the air side. Aluminum foil-faced fiberglass insulation shall be used in the heat compartment.
4. Base of unit shall have a minimum of four locations for thru-the-base gas and electrical connections (factory-installed or field-installed), standard.

Guide specifications (cont)

5. Base Rail:
 - a. Unit shall have base rails on a minimum of 2 sides.
 - b. Holes shall be provided in the base rails for rigging shackles to facilitate maneuvering and overhead rigging.
 - c. Holes shall be provided in the base rail for moving the rooftop by fork truck.
 - d. Base rail shall be a minimum of 16 gauge thickness.
6. Condensate pan and connections:
 - a. Shall be a sloped condensate drain pan made of a corrosion resistant material.
 - b. Shall comply with ASHRAE Standard 62.
 - c. Shall use a 3/4 in. 14 NPT drain connection, possible either through the bottom or side of the drain pan. Connection shall be made per manufacturer's recommendations.
7. Top panel:
 - a. Shall be a single piece top panel on 090-150 models and two piece on 180 size models.
8. Electrical Connections:
 - a. All unit power wiring shall enter unit cabinet at a single, factory prepared, knockout location.
 - b. Thru-the-base capability.
 - 1) Standard unit shall have a thru-the-base electrical location(s) using a raised, embossed portion of the unit basepan.
 - 2) Optional, factory approved, water-tight connection method must be used for thru-the-base electrical connections.
 - 3) No basepan penetration, other than those authorized by the manufacturer, is permitted.
9. Component access panels (standard):
 - a. Cabinet panels shall be easily removable for servicing.
 - b. Unit shall have one factory installed, tool-less, removable, filter access panel.
 - c. Panels covering control box, indoor fan, indoor fan motor, gas components (where applicable), and compressors shall have molded composite handles.
 - d. Handles shall be UV modified, composite. They shall be permanently attached, and recessed into the panel.
 - e. Screws on the vertical portion of all removable access panel shall engage into heat resistant, molded composite collars.
 - f. Collars shall be removable and easily replaceable using manufacturer recommended parts.

H. (23 81 19.13.H.) Coils:

1. Standard Aluminum Fin-Copper Tube Coils:
 - a. Standard evaporator and condenser coils shall have aluminum lanced plate fins mechanically bonded to seamless internally grooved copper tubes with all joints brazed.
 - b. Evaporator coils shall be leak tested to 150 psig, pressure tested to 450 psig, and qualified to UL 1995 burst test at 1775 psig.
 - c. Condenser coils shall be leak tested to 150 psig, pressure tested to 650 psig, and qualified to UL 1995 burst test at 1980 psig.
2. Optional Pre-coated aluminum-fin condenser coils:
 - a. Shall have a durable epoxy-phenolic coating to provide protection in mildly corrosive coastal environments.
 - b. Coating shall be applied to the aluminum fin stock prior to the fin stamping process to create an inert barrier between the aluminum fin and copper tube.
 - c. Epoxy-phenolic barrier shall minimize galvanic action between dissimilar metals.
 - d. Corrosion durability of fin stock shall be confirmed through testing to be no less than 1000 hours salt spray per ASTM B117-90.
 - e. Corrosion durability of fin stock shall be confirmed through testing to have no visible corrosion after 48 hour immersion in a room temperature solution of 5% salt, 1% acetic acid.
 - f. Fin stock coating shall pass 2000 hours of the following: one week exposure in the prohesion chamber followed by one week of accelerated ultraviolet light testing. Prohesion chamber: the solution shall contain 3.5% sodium chloride and 0.35% ammonium sulfate. The exposure cycle is one hour of salt fog application at ambient followed by one hour drying at 95°F (35°C).
3. Optional Copper-fin evaporator and condenser coils:
 - a. Shall be constructed of copper fins mechanically bonded to copper tubes and copper tube sheets.
 - b. Galvanized steel tube sheets shall not be acceptable.
 - c. A polymer strip shall prevent coil assembly from contacting the sheet metal coil pan to minimize potential for galvanic corrosion between coil and pan.
4. Optional E-coated aluminum-fin evaporator and condenser coils:
 - a. Shall have a flexible epoxy polymer coating uniformly applied to all coil surface areas without material bridging between fins.

Guide specifications (cont)

- b. Coating process shall ensure complete coil encapsulation of tubes, fins and headers.
 - c. Color shall be high gloss black with gloss per ASTM D523-89.
 - d. Uniform dry film thickness from 0.8 to 1.2 mil on all surface areas including fin edges.
 - e. Superior hardness characteristics of 2H per ASTM D3363-92A and cross-hatch adhesion of 4B-5B per ASTM D3359-93.
 - f. Impact resistance shall be up to 160 in.-lb (ASTM D2794-93).
 - g. Humidity and water immersion resistance shall be up to minimum 1000 and 250 hours respectively (ASTM D2247-92 and ASTM D870-92).
 - h. Corrosion durability shall be confirmed through testing to be no less than 1000 hours salt spray per ASTM B117-90.
- I. (23 81 19.13.I.) Refrigerant Components:
- 1. Refrigerant circuit shall include the following control, safety, and maintenance features:
 - a. Thermostatic Expansion Valve (TXV) shall help provide optimum performance across the entire operating range. Shall contain removable power element to allow change out of power element and bulb without removing the valve body.
 - b. Refrigerant filter drier — Solid core design.
 - c. Service gauge connections on suction and discharge lines.
 - d. Pressure gauge access through a specially designed access port in the top panel of the unit.
 - 2. Compressors:
 - a. Unit shall use two tandem scroll compressors on single independent refrigeration circuit.
 - b. Units shall have single circuit and two-stage cooling and contain two dual stage compressors.
 - c. Evaporator coils shall be a full active design to help better control comfort latent removal.
 - d. Compressor motors shall be cooled by refrigerant gas passing through motor windings.
 - e. Compressors shall be internally protected from high discharge temperature conditions.
 - f. Compressors shall be protected from an over-temperature and over-ampereage conditions by an internal, motor overload device.
 - g. Compressor shall be factory mounted on rubber grommets.
 - h. Compressor motors shall have internal line break thermal, current overload and high pressure differential protection.
 - i. Crankcase heaters shall not be required for normal operating range, unless required by compressor manufacturer due to refrigerant charge limits.
 - j. Compressors shall be a two-stage cooling capacity design.
- J. (23 81 19.13.J.) Return Air Filter Section:
- 1. Filters access is specified in the unit cabinet section of this specification.
 - 2. Filters shall be held in place by a pivoting filter tray, facilitating easy removal and installation.
 - 3. Shall consist of factory installed, low velocity, throw-away 2 in. thick fiberglass filters.
 - 4. Filters shall be standard, commercially available sizes.
 - 5. Only one size filter per unit is allowed.
- K. (23 81 19.13.K.) Evaporator Fan and Motor with X-Vane™ Fan Technology:
- 1. Direct Drive Evaporator fan motor:
 - a. Shall be a ECM motor design.
 - b. Shall have permanently lubricated bearings.
 - c. Shall have inherent automatic-reset thermal overload protection.
 - d. Shall have slow ramp up to speed capabilities.
 - e. Shall require no fan/motor belts for operation, adjustments and or initial fan speed set up.
 - f. Fan DC voltage set up on Unit Control Board can eliminate the need of removal of blower access door, required on conventional belt drive systems.
 - g. Shall be internally protected from electrical phase reversal and loss.
 - 2. Evaporator Fan:
 - a. Shall be easily set with dedicated selection switch and adjustment pot on unit control board.
 - b. Shall provide two-stage cooling capacity control, the indoor fan speed is automatically controlled to meet the code-compliant <66% low fan speed and 100% at full fan speed operation.
 - c. Blower fan shall be a Vane Axial fan design with 75% less moving parts than a conventional belt drive system.
 - d. Shall be constructed of a cast aluminum stator and high impact composite material on stator, rotor and air inlet casing.
 - e. Shall be a patented / pending design with a corrosion resistant material and dynamically balanced.

Guide specifications (cont)

- f. Shall have slow ramp up to speed capabilities to help reduce sound and comfort issues typically associated with single speed belt drive systems.
- g. Shall be a slide out design with removal of a few support brackets.
- 3. Shall include an easily accessible Unit Control Board to conveniently and safely provide connection points for vital control functions such as: smoke detectors, phase monitor, gas controller, economizer, thermostat, and low, high and mixed air temperature switches. Controller shall also provide an intuitive means to adjust the indoor fan speed through a simple switch and pot adjustment design.
- L. (23 81 19.13.L.) Condenser Fans and Motors:
 - 1. Condenser fan motors:
 - a. Shall be a totally enclosed motor.
 - b. Shall use permanently lubricated bearings.
 - c. Shall have inherent thermal overload protection with an automatic reset feature.
 - d. Shall use a shaft-down design on all sizes.
 - 2. Condenser Fans:
 - a. Shall be a direct-driven propeller type fan.
 - b. Shall have galvalum blades riveted to steel spider that have corrosion-resistant properties and shall be dynamically balanced.
- M. (23 81 19.13.M.) Special Features Options and Accessories:
 - 1. Integrated EconoMiSer® X Low Leak rate models.
 - a. Integrated, gear driven opposing modulating blade design type capable of simultaneous economizer and compressor operation.
 - b. Independent modules for vertical or horizontal return configuration shall be available. Vertical return modules shall be available as a factory installed option.
 - c. Damper blades shall be galvanized steel with composite gears. Plastic or composite blades on intake or return shall not be acceptable.
 - d. Shall include all hardware and controls to provide free cooling with outdoor air when temperature and/or humidity are below setpoints.
 - e. Shall be equipped with gear driven dampers for both the outdoor ventilation air and the return air for positive air stream control.
 - f. Standard leak rate shall be equipped with dampers not to exceed 2% leakage at 1 in. wg pressure differential.
 - g. Economizer controller on EconoMiSer X models shall be the Honeywell W7220 that provides:
 - 1) 2-line LCD interface screen for setup, configuration and troubleshooting.
 - 2) On-board Fault Detection and Diagnostics (FDD) that senses and alerts when the economizer is not operating properly, per California Title 24, ASHRAE 90.1 and IECC¹.
 - 3) Sensor failure loss of communication identification.
 - 4) Automatic sensor detection.
 - 5) Capabilities for use with multiple-speed or single speed indoor fan systems.
 - 6) Utilize digital sensors: Dry bulb and Enthalpy.
 - h. Shall be capable of introducing up to 100% outdoor air.
 - i. Shall be equipped with a barometric relief damper capable of relieving up to 100% return air and contain seals that meet ASHRAE 90.1 requirements.
 - j. Shall be designed to close damper(s) during loss-of-power situations with spring return built into motor.
 - k. Dry bulb outdoor air temperature sensor shall be provided as standard. Enthalpy sensor is also available on factory installed only. Outdoor air sensor setpoint shall be adjustable and shall range from 40°F to 100°F (4°C to 38°C). Additional sensor options shall be available as accessories.
 - l. The economizer controller shall also provide control of an accessory power exhaust unit function. Factory set at 100%, with a range of 0% to 100%.
 - m. The economizer shall maintain minimum airflow into the building during occupied period and provide design ventilation rate for full occupancy.
 - n. Dampers shall be completely closed when the unit is in the unoccupied mode.
 - o. Economizer controller shall accept a 2 to 10 vdc CO₂ sensor input for IAQ/DCV control. In this mode, dampers shall modulate the outdoor air damper to provide ventilation based on the sensor input.
 - p. Compressor lockout temperature on W7220 control is adjustable from -45°F to 80°F (-43°C to 27°C), set at a factory default of 32°F (0°C).

1. IECC is a registered trademark of the International Code Council, Inc.

Guide specifications (cont)

- q. Actuator shall be direct coupled to economizer gear. No linkage arms or control rods shall be acceptable.
 - r. Economizer controller shall provide indications when in free cooling mode, in the DCV mode, or the exhaust fan contact is closed.
2. Integrated EconoMiSer® X Ultra Low Leak rate models.
- a. Integrated, gear driven opposing modulating blade design type capable of simultaneous economizer and compressor operation.
 - b. Independent modules for vertical or horizontal return configuration shall be available. Vertical return modules shall be available as a factory-installed option.
 - c. Damper blades shall be galvanized steel with composite gears. Plastic or composite blades on intake or return shall not be acceptable.
 - d. Shall include all hardware and controls to provide free cooling with outdoor air when temperature and/or humidity are below setpoints.
 - e. Shall be equipped with gear driven dampers for both the outdoor ventilation air and the return air for positive air stream control.
 - f. Ultra Low Leak design meets California Title 24 section 140.4 and ASHRAE 90.1 requirements for 4 cfm per sq ft on the outside air dampers and 10 cfm per sq ft on the return dampers.
 - g. Economizer controller on EconoMiSer X models shall be the Honeywell W7220 that provides:
 - 1) 2-line LCD interface screen for setup, configuration and troubleshooting.
 - 2) On-board Fault Detection and Diagnostics (FDD) that senses and alerts when the economizer is not operating properly, per California Title 24, ASHRAE 90.1 and IECC.
 - 3) Sensor failure loss of communication identification.
 - 4) Automatic sensor detection.
 - 5) Capabilities for use with multiple-speed indoor fan systems.
 - 6) Utilize digital sensors: Dry bulb and Enthalpy.
 - h. Shall be capable of introducing up to 100% outdoor air.
 - i. Shall be equipped with a barometric relief damper capable of relieving up to 100% return air and contain seals that meet ASHRAE 90.1 requirements.
 - j. Shall be designed to close damper(s) during loss-of-power situations with spring return built into motor.
 - k. Dry bulb outdoor air temperature sensor shall be provided as standard. Enthalpy sensor is also available on factory installed only. Outdoor air sensor setpoint shall be adjustable and shall range from 40°F to 100°F (4°C to 38°C). Additional sensor options shall be available as accessories.
 - l. The economizer controller shall also provide control of an accessory power exhaust unit function. Factory set at 100%, with a range of 0% to 100%.
 - m. The economizer shall maintain minimum airflow into the building during occupied period and provide design ventilation rate for full occupancy.
 - n. Dampers shall be completely closed when the unit is in the unoccupied mode.
 - o. Economizer controller shall accept a 2 to 10 vdc CO₂ sensor input for IAQ/DCV control. In this mode, dampers shall modulate the outdoor air damper to provide ventilation based on the sensor input.
 - p. Compressor lockout temperature on W7220 control is adjustable from -45°F to 80°F (-43°C to 27°C), set at a factory default of 32°F (0°C). W7212 control opens at 35°F (2°C) and closes at 50°F (10°C).
 - q. Actuator shall be direct coupled to economizer gear. No linkage arms or control rods shall be acceptable.
 - r. Economizer controller shall provide indications when in free cooling mode, in the DCV mode, or the exhaust fan contact is closed.
3. Two-Position Damper (Field-installed only):
- a. Damper shall be a Two-Position Damper. Damper travel shall be from the full closed position to the field adjustable %-open setpoint.
 - b. Damper shall include adjustable damper travel from 25% to 100% (full open).
 - c. Damper shall include single or dual blade, gear driven dampers and actuator motor.
 - d. Actuator shall be direct coupled to damper gear. No linkage arms or control rods shall be acceptable.
 - e. Damper will admit up to 100% outdoor air for applicable rooftop units.
 - f. Damper shall close upon indoor (evaporator) fan shutoff and/or loss of power.
 - g. The damper actuator shall plug into the rooftop unit's wiring harness plug. No hard wiring shall be required.

Guide specifications (cont)

- h. Outside air hood shall include aluminum water entrainment filter.
- 4. Manual damper (field-installed only):
 - a. Manual damper package shall consist of damper, air inlet screen, and rain hood which can be preset to admit up to 25% or 50% outdoor air for year round ventilation.
- 5. Hot Gas Re-Heat Dehumidification System:
 - a. The Hot Gas Re-Heat Dehumidification System shall be factory installed and shall provide greater dehumidification of the occupied space by two modes of dehumidification operations in addition to its normal design cooling mode:
 - 1) Subcooling mode further sub cools the hot liquid refrigerant leaving the condenser coil when both temperature and humidity in the space are not satisfied.
 - 2) Hot gas reheat mode shall mix a portion of the hot gas from the discharge of the compressor with the hot liquid refrigerant leaving the condenser coil to create a two-phase heat transfer in the system, resulting in a neutral leaving air temperature when only humidity in the space is not satisfied.
 - 3) Includes low ambient controller.
- 6. Low Ambient Control Package:
 - a. Controller shall control coil head pressure by condenser fan speed modulation or condenser fan cycling and wind baffles.
 - b. Shall consist of solid-state control and condenser coil temperature sensor to maintain condensing temperature between 90°F (32°C) and 110°F (43°C) at outdoor ambient temperatures down to 0°F (-18°C).
- 7. Condenser Coil Hail Guard Assembly:
 - a. Shall protect against damage from hail.
 - b. Shall be either hood style or louvered.
- 8. Unit-Mounted, Non-Fused Disconnect Switch (Available on 7.5 to 12.5 ton units with MOCPs of 80 amps or less, or 15 ton units with MOCPs of 100 amps or less):
 - a. Switch shall be factory installed, internally mounted.
 - b. National Electric Code (NEC) and UL approved non-fused switch shall provide unit power shutoff.
 - c. Shall be accessible from outside the unit.
 - d. Shall provide local shutdown and lockout capability.
 - e. Sized only for the unit as ordered from the factory. Does not accommodate field-installed devices.

- 9. Convenience Outlet:
 - a. Powered convenience outlet.
 - 1) Outlet shall be powered from main line power to the rooftop unit.
 - 2) Outlet shall be powered from line side or load side of disconnect by installing contractor, as required by code. If outlet is powered from load side of disconnect, unit electrical ratings shall be UL certified and rated for additional outlet amperage.
 - 3) Outlet shall be factory-installed and internally mounted with easily accessible 115-v female receptacle.
 - 4) Outlet shall include 15 amp GFI receptacles with independent fuse protection.
 - 5) Voltage required to operate convenience outlet shall be provided by a factory installed step-down transformer.
 - 6) Outlet shall be accessible from outside the unit.
 - 7) Outlet shall include a field installed "Wet in Use" cover.
 - b. Factory-Installed Non-Powered convenience outlet.
 - 1) Outlet shall be powered from a separate 115/120v power source.
 - 2) A transformer shall not be included.
 - 3) Outlet shall be factory-installed and internally mounted with easily accessible 115-v female receptacle.
 - 4) Outlet shall include 15 amp GFI receptacles with independent fuse protection.
 - 5) Outlet shall be accessible from outside the unit.
 - 6) Outlet shall include a field installed "Wet in Use" cover.
 - c. Field-Installed Non-Powered convenience outlet.
 - 1) Outlet shall be powered from a separate 115/120v power source.
 - 2) A transformer shall not be included.
 - 3) Outlet shall be field-installed and internally mounted with easily accessible 115-v female receptacle.
 - 4) Outlet shall include 20 amp GFI receptacles. This kit provides a flexible installation method which allows code compliance for height requirements of the GFCI outlet from the finished roof surface as well as the capability to relocate the outlet to a more convenient location.
 - 5) Outlet shall be accessible from outside the unit.

Guide specifications (cont)

- 6) Outlet shall include a field installed "Wet in Use" cover.
10. Thru-the-Base Connectors:
 - a. Kits shall provide connectors to permit gas and electrical connections to be brought to the unit through the unit basepan.
 - b. Minimum of four connection locations per unit.
11. Supply Duct Cover (size 180 only):
 - a. Required when field converting the factory standard vertical duct supply to horizontal duct supply configuration. One required per unit.
12. Propeller Power Exhaust:
 - a. Power exhaust shall be used in conjunction with an integrated economizer.
 - b. Independent modules for vertical or horizontal return configurations shall be available.
 - c. Horizontal power exhaust is shall be mounted in return ductwork.
 - d. Power exhaust shall be controlled by economizer controller operation. Exhaust fans shall be energized when dampers open past the 0 to 100% adjustable setpoint on the economizer control.
13. Roof Curbs (Vertical):
 - a. Full perimeter roof curb with exhaust capability providing separate air streams for energy recovery from the exhaust air without supply air contamination.
 - b. Formed galvanized steel with wood nailer strip and shall be capable of supporting entire unit weight.
 - c. Permits installation and securing of ductwork to curb prior to mounting unit on the curb.
14. Outdoor Air Enthalpy Sensor:
 - a. The outdoor air enthalpy sensor shall be used to provide single enthalpy control. When used in conjunction with a return air enthalpy sensor, the unit will provide differential enthalpy control. The sensor allows the unit to determine if outside air is suitable for free cooling.
15. Return Air Enthalpy Sensor:
 - a. The return air enthalpy sensor shall be used in conjunction with an outdoor air enthalpy sensor to provide differential enthalpy control.
16. Indoor Air Quality (CO₂) Sensor:
 - a. Shall be able to provide demand ventilation indoor air quality (IAQ) control.
 - b. The IAQ sensor shall be available in duct mount, wall mount, or wall mount with LED display. The setpoint shall have adjustment capability.
17. Smoke Detectors (factory-installed only):
 - a. Shall be a four-wire controller and detector.
 - b. Shall be environmental compensated with differential sensing for reliable, stable, and drift-free sensitivity.
 - c. Shall use magnet-activated test/reset sensor switches.
 - d. Shall have tool-less connection terminal access.
 - e. Shall have a recessed momentary switch for testing and resetting the detector.
 - f. Controller shall include:
 - 1) One set of normally open alarm initiation contacts for connection to an initiating device circuit on a fire alarm control panel.
 - 2) Two Form-C auxiliary alarm relays for interface with rooftop unit or other equipment.
 - 3) One Form-C supervision (trouble) relay to control the operation of the Trouble LED on a remote test/reset station.
 - 4) Capable of direct connection to two individual detector modules.
 - 5) Can be wired to up to 14 other duct smoke detectors for multiple fan shut-down applications.
18. Winter Start Kit:
 - a. Shall contain a bypass device around the low pressure switch.
 - b. Shall be required when mechanical cooling is required down to 25°F (-4°C).
 - c. Shall not be required to operate on an economizer when below an outdoor ambient of 40°F (4°C).
19. Time Guard:
 - a. Shall prevent compressor short-cycling by providing a 5 minute delay (±2 minutes) before restarting a compressor after shut-down for any reason.
 - b. One device shall be required per compressor.
20. Disconnect Switch Bracket (size 180 only):
 - a. Provides a pre-engineered and sized mounting bracket for applications requiring a unit mounted fused and non-fused disconnect of greater than 100 amps. Bracket assures that no damage will occur to coils when mounting with screws and other fasteners.
21. Hinged Access Panels:
 - a. Shall provide easy access through integrated quarter turn latches.

Guide specifications (cont)

- b. Shall be on major panels of: filter, control box, fan motor, and compressor.
22. Condensate Overflow Switch:
- a. This sensor and related controller monitors the condensate level in the drain pan and shuts down compression operation when overflow conditions occur. It includes:
 - 1) Indicator light — solid red (more than 10 seconds on water contact — compressors disabled), blinking red (sensor disconnected).
 - 2) 10 second delay to break — eliminates nuisance trips from splashing or waves in pan (sensor needs 10 seconds of constant water contact before tripping).
 - 3) Disables the compressors operation when condensate plug is detected, but still allows fans to run for economizer.
23. 4 in. filter rack kit:
- a. The 4 in. filter rack accessory kit is designed to hold 4 in. MERV-8 or MERV-13 filters. Filters not included in kit.
24. 2 in. MERV-13 Return Air filters:
- a. Accessory kit to field upgrade standard unit filters to 2 in. MERV-13 filters.
25. 2 in. MERV-8 Return Air filters:
- a. Accessory kit to field upgrade standard unit filters to 2 in. MERV-8 filters.
26. Phase Monitor Control:
- a. Shall monitor the sequence of three phase electrical system to provide a phase reversal protection.
 - b. Shall monitor the three phase voltage inputs to provide a phase loss protection for the three phase device.
 - c. Will work on either a Delta or Wye power connection.
27. Horn/Strobe Annunciator:
- a. Provides an audible/visual signaling device for use with factory-installed option or field installed accessory smoke detectors.
 - 1) Requires installation of a field-supplied 24-v transformer suitable for 4.2 VA (AC) or 3.0 VA (DC) per horn/strobe accessory.
 - 2) Requires field-supplied electrical box, North American 1-gang box, 2 in. (51 mm) x 4 in. (102 mm).
 - 3) Shall have a clear colored lens.
28. Electric Heat:
- a. Heating Section:
 - 1) Heater element open coil resistance wire, nickel-chrome alloy, 0.29 inches inside diameter, strung through ceramic insulators mounted on metal frame. Coil ends are staked and welded to terminal screw slots.
 - 2) Heater assemblies are provided with integral fusing for protection of internal heater circuits not exceeding 48 amps each. Auto reset thermo limit controls, magnetic heater contactors (24 v coil) and terminal block all mounted in electric heater control box (minimum 18 ga galvanized steel) attached to end of heater assembly.
29. UV-C Ultraviolet Lamp Kit:
- a. High-output, low temperature ultraviolet lamp accessory. It includes:
 - 1) lamp, interlock switch, mounting brackets, necessary wires, wire ties, screws and labels to field install kit in unit return air plenum.
 - 2) Separate dedicated 115v power source required.
 - 3) UV-C kit can not be used on units with Hot Gas Re-Heat system.