



# R32 HEAT PUMP CONDENSER INSTALLATION & OWNER'S MANUAL

---

## MODELS

ACIQ-18-HP-E-32  
ACIQ-24-HP-E-32  
ACIQ-30-HP-E-32  
ACIQ-36-HP-E-32  
ACIQ-48-HP-E-32  
ACIQ-60-HP-E-32

ENGLISH

※ This manual provides a detailed description of the precautions that the user should be mindful of during operation.  
※ Keep this manual, after reading it, for future reference.

Version Date: 10-15-25

# Contents

Warning .....	1
Safety Precautions .....	3
Notices for Usage .....	5
Notices for Installation .....	6
Installation Diagram .....	6
Before Operation Check List .....	7
Installation of the Outdoor Unit .....	8
Electric Wiring Work .....	14
Fault Code .....	17
Testing and Inspection .....	18
Maintenance Notice .....	19

**Note:**

- *All the illustrations in this manual are for explanation purpose only.*
- *Your air conditioner may be slightly different. The actual shape shall prevail.*
- *They are subject to change without notice for future improvement.*

# Warning

## ⌘ FCC WARNING

WARNING: Changes or modifications to this unit not expressly approved by the party responsible for compliance could void the user's authority to operate the equipment.

## ⌘ FCC STATEMENT

This device complies with Part 15 of the FCC Rules. Operation is subject to the following two conditions:

(1) this device may not cause harmful interference, and (2) this device must accept any interference received, including interference that may cause undesired operation.

NOTE: This equipment has been tested and found to comply with the limits for a Class B digital device, pursuant to part 15 of the FCC Rules. These limits are designed to provide reasonable protection against harmful interference in a residential installation. This equipment generates, uses and can radiate radio frequency energy and, if not installed and used in accordance with the instructions, may cause harmful interference to radio communications. However, there is no guarantee that interference will not occur in a particular installation. If this equipment does cause harmful interference to radio or television reception, which can be determined by turning the equipment off and on, the user is encouraged to try to correct the interference by one or more of the following measures:

- Reorient or relocate the receiving antenna.
- Increase the separation between the equipment and receiver.
- Connect the equipment into an outlet on a circuit different from that to which the receiver is connected.
- Consult the dealer or an experienced radio/TV technician for help.

## ⌘ IC STATEMENT





This device complies with Industry Canada licenceexempt RSS standard(s).

Operation is subject to the following two conditions: (1) this device may not cause interference, and (2) this device must accept any interference, including interference that may cause undesired operation of the device.

## ⌘ IC STATEMENT

This equipment complies with FCC's and IC's RF radiation exposure limits set forth for an uncontrolled environment. The antenna(s) used for this transmitter must be installed and operated to provide a separation distance of at least 7-7/8in.(20cm) from all persons and must not be collocated or operating in conjunction with any other antenna or transmitter. Installers must ensure that 7-7/8in.(20cm) separation distance will be maintained between the device (excluding its handset) and users.

# Warning

Symbol	Note	Explanation
 A2L	WARNING	This symbol shows that this appliance uses a flammable refrigerant. If the refrigerant is leaked and exposed to an external ignition source, there is a risk of fire. (Only for the AC with UL or ETL-MARKING, UL60335-2-40)
	CAUTION	This symbol shows that the operation manual should be read carefully.
	CAUTION	This symbol shows that a service personnel should be handling this equipment with reference to the installation manual.
	CAUTION	This symbol shows that information is available such as the operating manual or installation manual.

**NOTE:**

**The Air conditioner with R32 refrigerant, if roughly treated, may cause serious harm to the human body or surrounding things.**

- The room space and maximum refrigerant charge requirements are shown in the table.
- If ice has formed on the unit, do not use means to accelerate the defrosting process other than those recommended by the manufacturer.
- Do not use any cleaners on the unit other than what's approved by the manufacture.
- Do not pierce or burn air conditioner and ensure that the refrigerant pipeline is not damaged.
- The appliance must be stored in a room without continuously operating ignition sources (for example: open flames, an operating gas appliance or an operating electric heater).
- Notice that the refrigerant may be odorless.
- The storage of the air conditioner should be in a location that's able to prevent unintentional damage to the unit.
- Be sure to follow all local codes and safety requirements.

**Room Space and Maximum Refrigerant Charge Requirements**

Refrigerant Type	Allowable Refrigerant Charge Amount, (oz(kg))	Min. Floor Area For Installation, (ft <sup>2</sup> (m <sup>2</sup> ))
R32	< 64.9 (< 1.84)	75.35 (7)
	64.9~82.54 (1.84~2.34)	86.11 (8)
	82.58~100.18 (2.341~2.84)	96.88 (9)
	100.21~117.82 (2.841~3.34)	107.64 (10)
	117.85~135.45 (3.341~3.84)	129.17 (12)
	135.49~153.09 (3.841~4.34)	139.93 (13)
	153.12~170.73 (4.341~4.84)	161.46 (15)
	170.76~188.36 (4.841~5.34)	199.13 (18.5)
	188.4~206 (5.341~5.84)	236.81 (22)
	206.04~223.64 (5.841~6.34)	279.86 (26)
223.67~241.27 (6.341~6.84)	322.92 (30)	

Note:

Data calculation scenario: The minimum installation height of the duct outlet from the floor is 7.22ft. (2.2m).

# Safety Precautions

Incorrect installation or operation by not following these instructions may cause harm or damage to people, properties, etc. The seriousness is classified by the following indications:

**⚠ WARNING**

This symbol indicates the possibility of death or serious injury.

**⚠ CAUTION**

This symbol indicates the possibility of injury or damage to properties.

- 🚫 Things you shouldn't do.
- ❗ Follow the instructions.
- 🔌 Cut the power off.
- 🌿 Environmental notices.

**⚠ WARNING** 

- **Don't** connect the ground wire to the gas pipeline, water pipeline, lightning rod, or telephone earth wire.
- **Don't** pull the power cable .Pulling the power cable could result in damage to the unit and electrical shock.
- **Don't** cut off main power switch during operating or with wet hands.It may cause electric shock.
- **Don't** let the air conditioner blow against the heater appliance. Otherwise it will lead to incomplete combustion, thus causing poisoning.
- **Don't** let the remote control and the indoor unit watered or being too wet. Exposure to excessive moisture may cause damage to the unit and or electrical shock.
- **Don't** install the air conditioner in a place where there is flammable gas or liquid unless the distance is equal to or greater than 3-1/4ft.(1m) apart.
- **Don't** use any unapproved liquid or cleaning agent to clean the air conditioner.
- **Don't** attempt to repair the air conditioner by yourself. Incorrect repairs may cause fire or explosion. Contact a qualified service technician for all service requirement.
- **Don't** operate the air conditioner during a lightning storm. The power should be switched off to prevent danger or injury.
- **Don't** put hands or any objects into the air inlets or outlets.This may cause personal injury or damage to the unit.
- **Don't** block air inlet or air outlet.Otherwise, the cooling or heating capacity will be diminished, or cause the system to stop operating.
- **The** storage of the appliance should be in accordance with the applicable regulations

**⚠ WARNING** 

- **Always** switch off the device and cut the power supply when the unit is not in use for long time so as to ensure safety.
- **Always** switch off the device and cut the power supply before performing any maintenance or cleaning. Otherwise, it may cause electric shock or damage.

**⚠ DANGER PELIGRO**



**CARBON MONOXIDE POISONING HAZARD**

**Special Warning for Installation of Furnace or Air Handling Units in Enclosed Areas such as Garages, Utility Rooms or Parking Areas.**

Carbon monoxide producing devices (such as an automobile, space heater, gas water heater, etc.) should not be operated in enclosed areas such as unventilated garages, utility rooms or parking areas because of the danger of carbon monoxide (CO) poisoning resulting from the exhaust emissions. If a furnace or air handler is installed in an enclosed area such as a garage, utility room or parking area and a carbon monoxide producing device is operated therein, there must be adequate, direct outside ventilation. This ventilation is necessary to avoid the danger of CO poisoning which can occur if a carbon monoxide producing device continues to operate in the enclosed area. Carbon monoxide emissions can be (re) circulated throughout the structure if the furnace or air handler is operating in any mode.

**CO can cause serious illness including permanent brain damage or death.**

**⚠ WARNING** 

- This product contains fluorinated greenhouse gases.**
- **Refrigerant** leakage will contribute to climate change.
  - **Never** tamper with the refrigerant system or attempt repair without proper training and compliance to local and national codes.
  - **The** refrigerant in this system has a lower global warming potential (GWP) than a refrigerant with higher GWP, if leaked to the atmosphere. This appliance contains a refrigerant fluid with a GWP equal to [675]. This means that if 35 oz (1kg) of this refrigerant fluid would be leaked to the atmosphere, the impact on global warming would be [675] times higher than 35 oz (1kg) of CO<sub>2</sub>, over a period of 100 years.

# Safety Precautions

## ⚠ WARNING



- **This** appliance is not intended for use by persons (including children) with reduced physical, sensory or mental capabilities, or lack of experience and knowledge, unless they have been given supervision or instruction concerning use of the appliance by a person responsible for their safety.
- **Children** should be supervised to ensure that they do not play with the appliance.
- **Please** mount the system on a secure surface to prevent the unit from falling and causing injury or damage.
- **The** appliance shall be installed in accordance with national wiring regulations.
- **If** the supply cord is damaged, it must be replaced by the manufacturer, its service agent or similarly qualified persons in order to avoid a hazard.
- **Contact** a qualified service technician for all service requirements.
- **The** air conditioner must be grounded. Incomplete grounding may result in electric shocks.
- **Make sure** that the system has its own dedicated electrical circuit and that all electrical work is conducted by an individual that is certified or licensed to do such work in the state or region in which the insulation is taking place.
- **Ensure** the following objects are not under the indoor unit: Microwaves, ovens and other hot objects. Computers and other high electrostatic appliances. Electrical sockets. Items susceptible to water damage.
- **The** piping between indoor and outdoor unit shall not be reused, unless they can be properly flushed and re-flared.
- **The** specifications for electrical requirements are listed on the data plate of the unit.
- **WARNING RISK OF ELECTRIC SHOCK. CAN CAUSE INJURY OR DEATH:** System contains oversize protective earthing (grounding) terminal which shall be properly connected.
- **WARNING RISK OF ELECTRIC SHOCK. CAN CAUSE INJURY OR DEATH:** System contains two independent protective earthing (grounding) terminals which both shall be properly connected and secured.

## ⚠ CAUTION



- **Don't** operate the system with windows or doors open. Doing so will limit the system effectiveness.
- **Don't** stand on the top of the outdoor unit or place heavy objects on it. This could cause personal injuries or damage to the unit.
- **Don't** use the system for other purposes, such as drying clothes, preserving foods, etc.
- **Don't** apply the cold air to the body for a long time. It will deteriorate your physical conditions and cause health problems.

## ⚠ CAUTION



- **Appropriate** adjustments of the setting temperature can prevent the waste of electricity.
- **Use** an all-pole disconnection type breaker with at least 1/8 in. (3mm) between the contact point gaps that provide full disconnection under overvoltage category III.
- **If** your air conditioner is permanently connected to the fixed wiring, a residual current device (RCD) having rated residual operating current not exceeding 30 mA should be installed in the fixed wiring.
- **The** power supply circuit should have leakage protector and air switch of which the capacity should be more than 1.5 times of the maximum current.
- **Regarding** the installation of the air conditioners, please refer to the below paragraphs in this manual.
- **LEAK DETECTION SYSTEM installed. Unit must be powered except for service.** Continuous air circulation required for proper functioning. Unit must be powered except for service
- **This** unit is equipped with electrically powered safety measures. To be effective, the unit must be electrically powered at all times after installation, other than when servicing.

## E-Waste

**Meaning** of crossed out wheeled dustbin:

**Do not** dispose of electrical appliances as unsorted municipal waste, use separate collection facilities.

**Contact** you local government for information regarding the collection systems available.

**If** electrical appliances are disposed of in landfills or dumps, hazardous substances can leak into the groundwater and get into the food chain, damaging your health and well-being. When replacing old appliances with new ones, the retailer is legally obligated to take back your old appliance for disposals at least free of charge.



# Notices for Usage

## Operating Range

- Operating the unit outside the recommended temperature range may have an impact on the system performance. When the temperature is too high, the air conditioner may trip the circuit breaker causing the air conditioner to shut down. When the temperature is too low, the outdoor heat exchanger may generate excessive moisture, leading to water dripping from the unit.
- In long-term cooling or dehumidification with a relative humidity of above 80%, doors and windows should be closed to prevent the indoor unit from generating too much water and causing leaks.

Type	Range	Indoor	Outdoor
Regular	Cooling	60.8°F~89.6°F (16°C~32°C)	5°F~125.6°F (-15°C~52°C)
	Heating	50°F~89.6°F (10°C~32°C)	5°F~75.2°F (-15°C~24°C)

## Notes for Heating

- The fan of the indoor unit will not start immediately when the heating cycle has started. The unit will warm up and then start blowing air to avoid blowing out cool air.
- When it is cold and wet outside, the outdoor unit will develop frost over the heat exchanger which over time will cause the system to start the defrost function.
- During defrost, the air conditioner will stop heating for about 5-12 minutes.
- Vapor may come out from the outdoor unit during defrost. This is not a malfunction, but a result of fast defrost.
- Heating will resume after defrost is complete.

## Notes for Turning Off

- When the air conditioner is turned off, the main controller will automatically decide whether to stop immediately or after running for dozens of seconds with lower frequency and lower air speed.

## Important Notices

- This unit must be installed by a certified contractor to avoid:  
Damage to the unit  
Refrigerant leaking in the atmosphere  
Electrical shock  
Burns from refrigerant  
Other serious injuries including death
- Leak test must be made after installation.
- To move and install air conditioner to another place, please contact our local authorized contractor.

## Installation Environment Inspections

- Check nameplate of outdoor machine to make sure whether the refrigerant is R32.
- Check the floor space of the room. The space shall not be less than usable space in the specification.
- The outdoor unit shall be installed at a well-ventilated place.

- Check the surrounding environment of installation site: R32 shall not be installed in the enclosed reserved space of a building.
- When using electric drill to make holes in the wall, check first whether there is pre-buried pipeline for water, electricity and gas. It is suggested to use the reserved hole in the roof of the wall.

## Unpacking Inspections

- Open the box and check air conditioner in area with good ventilation and without ignition source.
- Note: Operators are required to wear anti-static devices.
- It is necessary to check whether there is refrigerant leakage before opening the box of outdoor machine; stop installing the air conditioner if leakage is found.
- The fire prevention equipment shall be prepared well before checking.
- Then check the refrigerant pipeline to see if there is any damage or leaks.

## Safety Principles for Installing Air Conditioner

- Fire prevention device shall be prepared before installation.
- Keep installing site ventilated. (open the door and window)
- Ignition source, smoking and calling is not allowed to exist in area where R32 refrigerant located.
- Anti-static precautions in necessary for installing air conditioner, e.g. wear pure cotton clothes and gloves.
- Keep leak detector in working state during the installation.
- If R32 refrigerant leakage occurs during the installation, you shall immediately detect the concentration in indoor environment until it reaches a safe level.
- If refrigerant leakage affects the performance of the air conditioner, please immediately stop the operation, and the air conditioner must be vacuumed firstly and be returned to the maintenance station for processing.
- Keep electric appliance, power switch, plug, socket, high temperature heat source and high static away from the area underneath sidelines of the indoor unit.
- The air conditioner shall be installed in an accessible location for installation and maintenance, without obstacles that may block air inlets or outlets of indoor /outdoor units. It shall be kept away from heat source, inflammable or explosive conditions as well.
- When installing or repairing the air conditioner and the connecting line is not long enough, the entire connecting line shall be replaced with the connecting line of the original specification; extension is not allowed.
- The indoor unit should be install in a room without continuously operating open flames (e.g. an operating gas appliance) or other POTENTIAL IGNITION SOURCES (for e.g. an operating electric heater, hot surfaces). A flame-producing device may be installed in the same space if the device is provided with an effective flame arrest.

## Requirements for Operations at Raised Height

- When carrying out installation at 6-9/16ft. (2m) or higher above the base level, safety belts must be worn and ropes of sufficient strength must be securely fastened to the outdoor unit to prevent falling that could cause personal injury or death as well as property loss.

# Notices for Installation

## Requirements for Installation Position

- Avoid places of flammable or explosive gas leakage or where there is poor ventilation.
- Avoid places subject to strong electric/magnetic fields like microwaves and florescent lights.
- Avoid places like subject to noise and resonance like walls above a sleeping area.
- Avoid severe natural conditions (e.g. strong wind, direct sunshine or high temperature heat sources).
- Avoid places within the reach of children.
- Shorten the connection between the indoor and outdoor units as much as possible for best performance.
- Select a location where it is easy to perform service and repair.
- The outdoor unit shall not be installed in any way that could occupy an aisle, stairway, exit, fire escape, catwalk or any other public area.
- The outdoor unit shall be installed as far as possible from the doors and windows of the neighbors as well as plants.

## Requirements of the Mounting Structure

- The mounting rack must meet the relevant national or industrial standards
- It is recommended that the mounting rack and its load carry surface shall be able to withstand 4 times or above the weight of the unit.
- The mounting rack of the outdoor unit shall be fastened with expansion bolts or as recommended by the manufacturer.
- Ensure the secure installation regardless of what type of wall on which it is installed, to prevent potential dropping that could cause damage or injury.

## Grounding Requirements

- Be sure to properly ground the unit. Follow all local and national codes as applicable.
- Do not connect the grounding wire to a gas pipe, water pipe, lightning rod, telephone line, or a circuit poorly grounded to the earth.
- The grounding wire is specially designed and shall not be used for other purpose, nor shall it be fastened with a common tapping screw.
- Ensure that all electrical connects are securely fasted and connected to the correct terminals.
- Local and national electrical codes must be utilized.
- The connection method of the air conditioner and the power cable and the interconnection method of each independent element shall be subject to the wiring diagram affixed to the machine.

## Others

- The connection method of the air conditioner and the power cable and the interconnection method of each independent element shall be subject to the wiring diagram affixed to the machine.
- The model and rating value of the fuse should match the information printed on the silkscreen of the corresponding controller or the fuse sleeve. This ensures that the fuse is correctly rated for the specific application, providing proper protection and functionality.

ENGLISH

# Installation Diagram

## Accessories

The air conditioning system comes with the following accessories. Use all of the installation parts and accessories to install the air conditioner. Improper installation may result in water leakage, electrical shock and fire, or equipment failure.

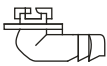
Installation Fittings		
Name	Shape	Quantity
Installation and owner's manual(this book)		1
Drain fitting		1

## Tools Required

Phillips screwdriver	Level	Refrigerant Scale
Utility knife or scissors	Torque wrench	Wrench (or spanner)
Clamp on Amp Meter	Hole Saw	Manifold and Gauges
Hexagonal Wrench	Flare tool	Pipe Cutter
Vacuum Pump	Safety Glasses	Work Gloves

# Before Operation Check List

For the following items, take special care during construction and check after installation is finished.

## 1. Items to be checked after completion of work

Items to be checked	If not properly done, what is likely to occur.	Check
Are the indoor and outdoor unit fixed firmly?	The units may drop, vibrate or make noise.	
Was the installation of the outdoor unit completed?	The unit may malfunction or the components burn out.	
Is the gas leak test finished?	No cooling or heating.	
Is the unit fully insulated? (Refrigerant piping, drain piping, and duct)	Condensate water may drip.	
Does drainage flow smoothly?	Condensate water may drip.	
Does the power supply voltage conform to the indication on the name plate?	The unit may malfunction or the components burn out.	
Are wiring and piping correct?	The unit may malfunction or the components burn out.	
Is the air conditioner or heat pump properly grounded?	Dangerous in case of current leakage.	
Is wiring size according to specifications?	The unit may malfunction or the components burn out.	
Is something blocking the air outlet or inlet of either the indoor or outdoor units?	No cooling or heating.	
Did you set the external static pressure?	No cooling or heating.	
Are refrigerant piping length and additional refrigerant charge noted down?	The refrigerant charge in the system is not clear.	
Did you check that no wiring connection screws were loose?	Electric shock or fire.	

## 2. Items to be checked at the time of delivery

Items to be checked	Check
Did you explain about operations while showing the operation manual to your customer?	
Did you deliver the operation manual along with the installation manual to the customer?	
Did you deliver instruction manual, if any, for the field supplies to the customer?	

## 3. Points for explanation about operations

The items with WARNING and CAUTION marks in the operation manual are the items pertaining to possibilities for bodily injury and material damage in addition to the general usage of the product. Accordingly, it is necessary that you make a full explanation about the described contents and also ask your customers to read the operation manual.

### Note to Installer

- Be sure to instruct customers how to properly operate the unit (especially cleaning filters, operating different functions, and adjusting the temperature) by having them carry out operations themselves while looking at the manual.

# Installation of The Outdoor Unit

## Outdoor Unit Dimensions

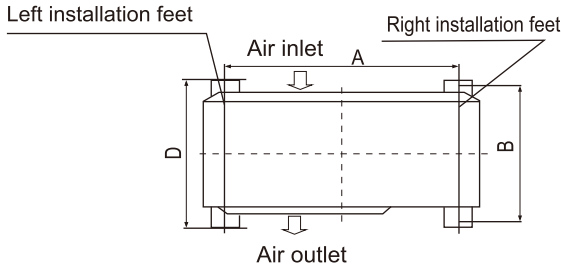
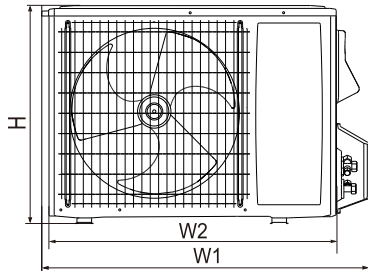

Outdoor Unit Size of Shape W1(W2)×H×D, in(mm)	A in.(mm)	B in.(mm)
38-9/16(35-5/16)×27-9/16×15-1/4 980(897)×700×388	24-7/8 (632)	13-7/8 (352)
41-3/16(38-3/16)×31-13/16×17-15/16 1046(970)×808×455	26-9/16 (675)	16-1/8 (409)
39-13/16(37)×51-15/16×15-12/16 1011(940)×1320×400	24-5/8 (625)	14-5/16 (364)

## Attention to Installation Site

### ⚠ CAUTION



- The installation place must be well-ventilated, so that the unit can be move enough air to operate correctly.
- The installation place must be enough firm to support the weight of outdoor unit and can iso late noise and vibration.
- Avoid direct sunlight, and if necessary a sun shelter should be mounted.
- The installation place should allow for the drainage or rainwater and water produced during defrosting.
- The installation place should prevent the unit from getting buried in a snowdrift.
- The unit should not be installed so that the fan blows into strong winds.
- Ensure that neither the air from the outdoor unit nor noise produced by it will affect the neighbours
- The unit must not be in a position where people will pile rubbish on to it or where it will be affected by exhaust gases
- In order to ensure the use effect, the external machine is not allowed to be installed in the basement or other closed rooms.

Where you install the outdoor unit will have a direct affect upon its performance.

- In order for the outdoor unit to operate at its best you should carefully follow these instructions. In particular its important to prevent discharge air to return to the rear of the unit. This should be avoided as this will significantly reduce the cooling and heating performance.
- The discharge air which is expelled from the front of the unit should not be allowed to immediately enter the return inlet of the back of the unit.
- Ensure there is ample space in front of the unit will help prevent this from happening.
- Ensure the unit is installed on a level surface and that there is plenty of room to service the equipment. Do not allow a slope of more than 5°.

The following gures show the right installation and wrong installation:

Wrong installation	
	⊗
	⊗
	⊗
Right installation	
	✓
	✓
	✓

# Installation of The Outdoor Unit

## Installation Guide at the Seaside

- Air conditioners should not be installed in areas where corrosive gases, such as acid alkaline gas, are produced.
- Do not install the product where it could be exposed to direct salt air. Sea air exposure can result in corrosion on the unit. Corrosion, particularly on the condenser and evaporator fins, could cause product malfunction, inefficient performance, and refrigerant leaks.
- If the outdoor unit is installed close to the seaside, it should avoid direct exposure to the sea wind. Otherwise, it may need additional anticorrosion treatment.
- The windbreak should be strong enough like concrete to prevent the sea wind from hitting the unit. The height and width should be more than 150% of the outdoor unit.
- Select a well-drained place. Install the outdoor unit on the opposite side of the direction of the sea wind, or set up a windbreak to avoid exposed to the sea wind. Seaside applications will require more frequent maintenance checks and cleaning. Be sure to keep the system free of salt build up by washing the unit with clean water at low pressure.
- The unit should be kept more than 27-9/16in.(70cm) from the windbreak for easy air flow.
- The mounting rack of the outdoor unit shall be fastened with expansion bolts or as the manufacture recommends.
- If installing on a wall, ensure the secure installation regardless of the type of to prevent potential dropping that could damage the unit or cause injury.

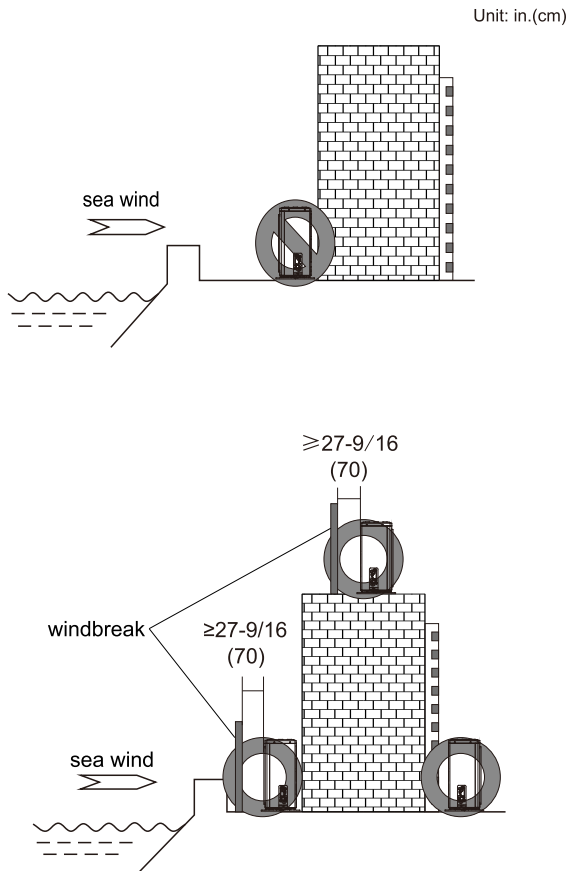

## Correct installation

### Caution :

- When unpacking, open the carton, please remove the packing foam first, then take out the air conditioner.
- Do not touch the heat exchanger at the rear of the indoor unit with your hands or any other object!
  - Handling with the handle and side angle, please handle with care, Do not drop the unit or allow it to fall during transport.
  - When the outdoor unit is to be lifted, please use two slings longer than 26-1/4ft (8m) and insert cushioning material between the slings and outdoor unit to avoid damaging the casing.

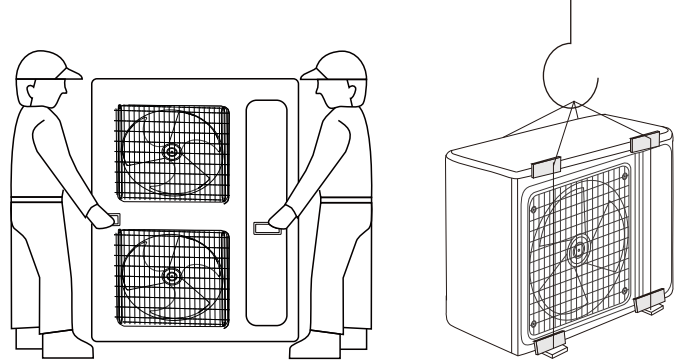

## Installation Drawing

This installation chart is for reference only

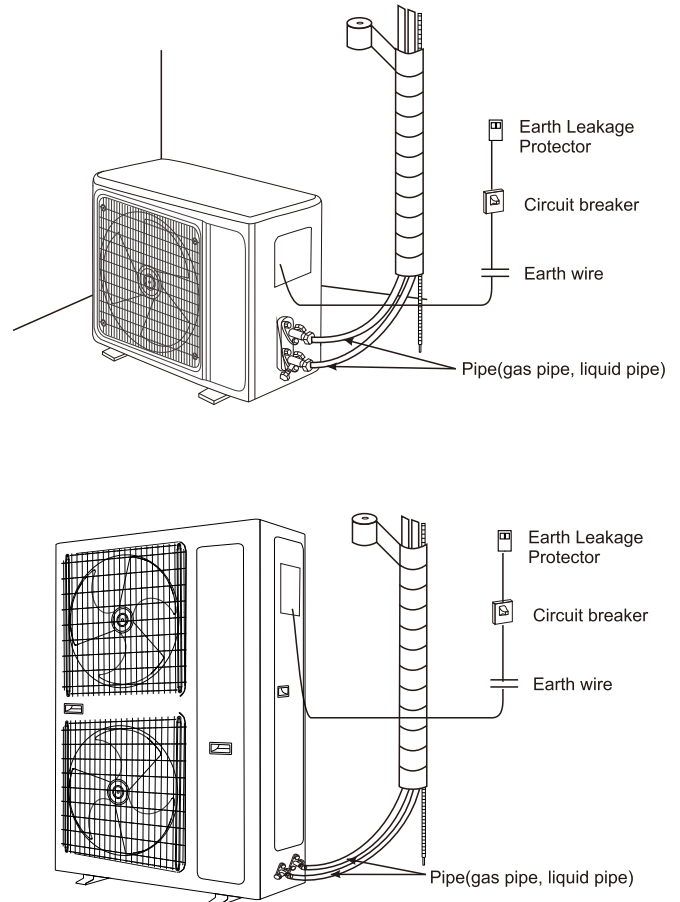

# Installation of The Outdoor Unit

## Select Installation Site

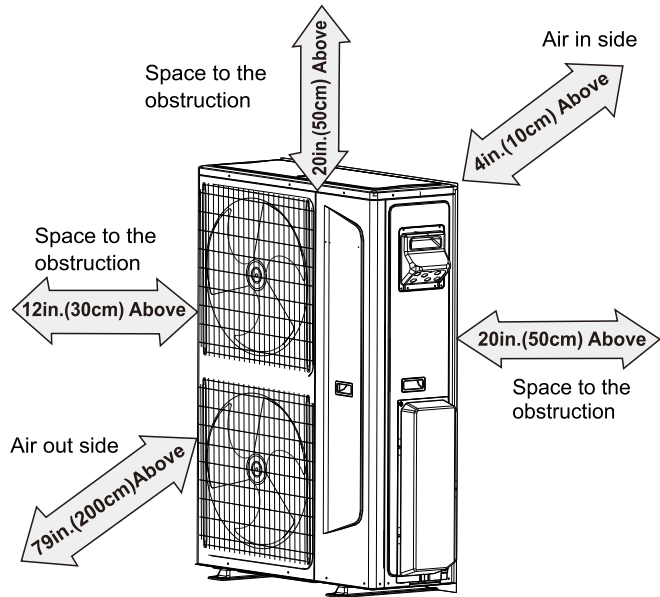
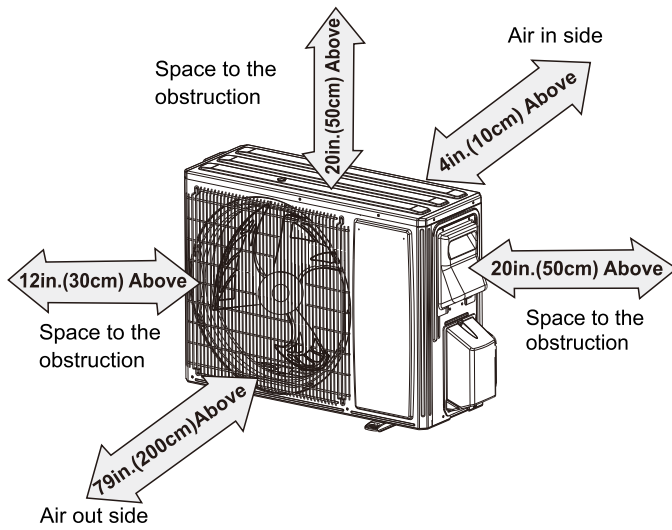

### CAUTION



- Install a drainage channel to allow the condensate to flow smoothly away.
- During installation please ensure that the foundations are secure and level to avoid vibration and noise
- Please bolt(M8 or M10) the outdoor unit down securely.
- The bolts for connecting the outdoor unit should protrude 13/16in. (20mm) above the surface of the base.
- Do not just use the four comers as a foundation to support the unit.

Unit: in.(mm)

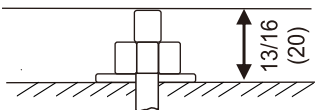

## Outdoor Condensation Drainage

### Heat pump type only

When the unit is in heating mode, the outdoor unit can generate water that will drip from the bottom of the unit. To control the flow of that water, please use the provided drain elbow.

#### Installation:

- Install the drain elbow in the 1in.( $\Phi$  25mm) hole on the bottom of the base plate, and connect the drain hose to the elbow. Route the hose to a location so that the water formed in the outdoor unit can be drained out to a proper location.
- In cold areas, do not use a the drain elbow or drain plugs on the outdoor unit. Plugging the holes will cause ice to buildup in the base pan which could result in damage to the unit. In cold climates, make sure the unit has plenty of space to drain and avoid snow drifts.
- The pipe should be installed with a downward gradient ( $>1/1.36$ ) to allow the water to drain away.
- The pipe should not rise at any point.

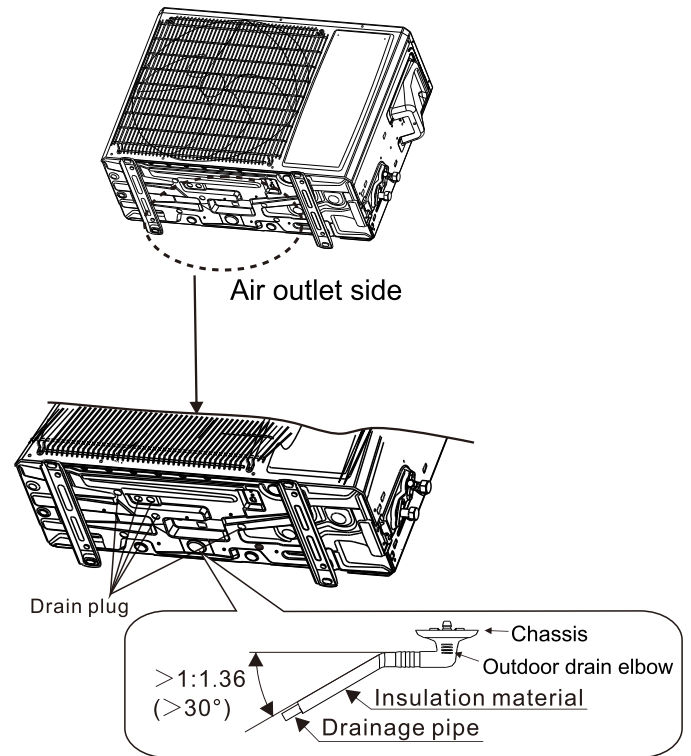

# Installation of The Outdoor Unit

## Connection of Refrigerant Pipe

The standard refrigerant pipe length is 25ft (7.5m) long. If the distance between the indoor and outdoor is longer than this, then the pipe needs to be extended.

Please refer to the following table for the limitations of each unit as far as maximum distance and height.

Do not exceed these limits or compressor failure may result.

Keep the pipe separation length and the number of bends to the lowest possibility and always follow the shortest path for the pipe installation.

As the pipe length and number of bends increases the performance of the unit decreases and energy use increases.

Model	Connecting pipe dim. (Øin.(mm))		Max. Connecting Length (ft(m))	Max. Difference In Level (ft(m))	Max. Bending number
	Liquid pipe	Gas pipe			
18K	3/8 (9.52)	5/8 (15.88)	98-7/16 (30)	49-3/16 (15)	6
24K	3/8 (9.52)	5/8 (15.88)	98-7/16 (30)	49-3/16 (15)	6
30K	3/8 (9.52)	5/8 (15.88)	98-7/16 (30)	49-3/16 (15)	6
36K	3/8 (9.52)	5/8 (15.88)	164-1/16 (50)	98-7/16 (30)	6
48K	3/8 (9.52)	3/4 (19.05)	164-1/16 (50)	98-7/16 (30)	8
60K	3/8 (9.52)	3/4 (19.05)	164-1/16 (50)	98-7/16 (30)	8

## Prevent Compressor Oil Return

- Horizontal pipes should incline toward the outdoor unit using a 20:1 slope.
- If there is a height difference between the indoor and outdoor unit, oil traps should be installed in the interconnecting gas (large) pipe:

When the vertical pipe height difference is less than 16-3/8ft (5m), an oil trap should be installed at the bottom of the gas (large) pipe. When the vertical pipe height difference is more than 16-3/8ft (5m), then for every 16-3/8ft (5m) an oil trap must be installed at the bottom of the gas (large) pipe, and a short loop (liquid ring) should be installed at the exit of the indoor unit liquid (small) pipe:

When the connecting gas pipe vertical height difference is less than 16-3/8ft (5m) but the constant rise distance is too long, an oil trap should be installed in the gas (large) pipe every 32-13/16ft (10m).

### Note:

**This chart is for explanation purposes. An actual installation maybe different from this and it should consider the site conditions. When making an oil trap the radius of the bend should be between 1.5 and 2 times the pipe diameter.**

When the installation position of indoor unit is higher than that of the outdoor unit.

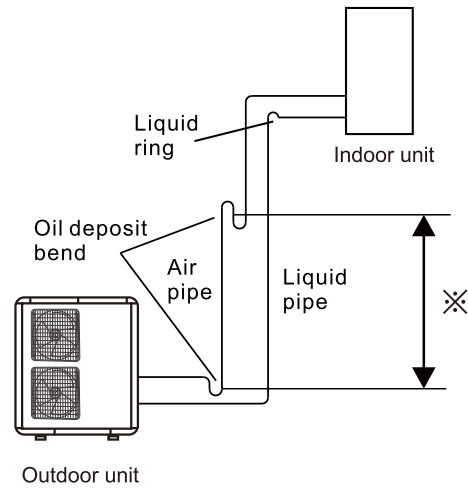

When the installation position of indoor unit is lower than that of the outdoor unit.

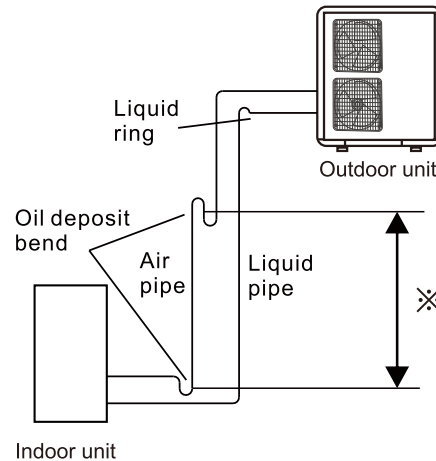

※ means that each height difference sets an oil deposit bend.

Model	Difference of Height(ft(m))
18K	19-11/16 (6)
24K	
30K	
36K	32-13/16 (10)
48K	
60K	

# Installation of The Outdoor Unit

## Piping Works and Flaring Techniques

- Do not use contaminated or damaged copper tubing. If the evaporator, condenser, or any piping has been open and exposed to the atmosphere for 15 seconds or more, the system must be vacuumed. Do not remove plastic plugs or brass nuts from piping connections until the connections are ready to be made.
- If any brazing work is required, ensure that a nitrogen gas purge is utilized to prevent soot formation on the inside wall of copper tubing. Failure to do so may cause damage to the unit and void warranty.
- Cut the pipe as straight as possible (See Fig. 1). Make sure to use a deburring tool to remove any burrs. Hold the pipe with opening facing down to prevent metal chips from entering the pipe (See Fig. 2).
- This will avoid unevenness on the flare faces which will cause gas leak.
- Insert the flare nuts, mounted on the connection parts of both the indoor unit and outdoor unit, into the copper pipes.
- The exact length of pipe protruding from the top surface of the swaging block is determined by the flaring tool. (See Fig. 3)
- Fix the pipe firmly on the swaging block. Match the centers of both the swaging block and the flaring punch, then tighten the flaring punch fully.
- The refrigerant pipe connection are insulated by closed cell polyurethane.

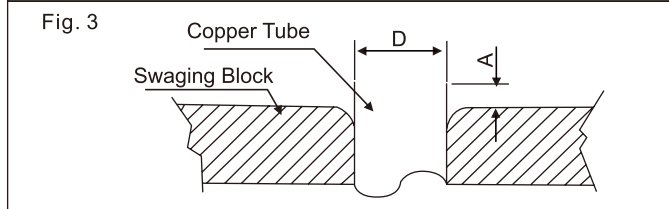
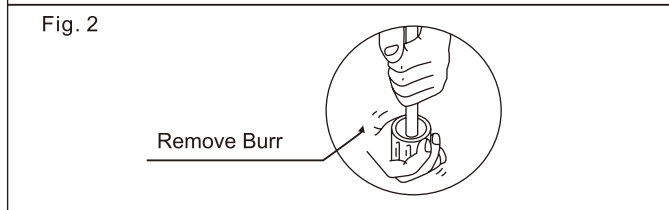
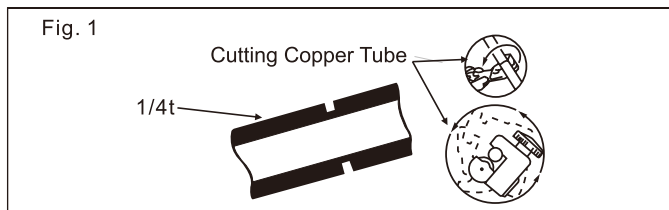

Ø Tube, D		A(Inch/mm)	
Inch	mm	Imperial (Wing-nut Type)	Rigid (Clutch Type)
1/4	6.35	0.051" (1.3)	0.028" (0.7)
3/8	9.52	0.063" (1.6)	0.039" (1.0)
1/2	12.70	0.075" (1.9)	0.051" (1.3)
5/8	15.88	0.087" (2.2)	0.067" (1.7)
3/4	19.05	0.098" (2.5)	0.079" (2.0)

Observe the requirements listed below for refrigerant piping sizes .

model	liquid(in.(mm))	Gas(in.(mm))
18K/24K/30K/36K	Ø3/8 (Ø9.52)	Ø5/8 (Ø15.88)
48K/60K	Ø3/8 (Ø9.52)	Ø3/4 (Ø19.05)

NOTE:

It is recommended that all connecting copper pipes be insulated.

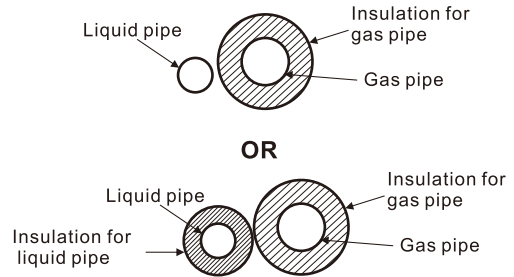

## Install The Connection Pipe

### Connect the pipe to the unit

Align the center of the piping and tighten the flare nut sufficiently with fingers.

Finally, tighten the flare nut with torque wrench until the wrench clicks.

When tightening the flare nut with the torque wrench, ensure that the tightening direction follows the arrow indicated on the wrench.

The refrigerant pipe connection are insulated by closed cell polyurethane.

### Tightening torque table

The size of pipe, in.(mm)	Torque, ft-lb(N-m)
Ø1/4 (Ø6.35)	11.0-18.4 (15-25)
Ø3/8 (Ø9.52)	25.8-29.5 (35-40)
Ø1/2 (Ø12.7)	33.2-44.3 (45-60)
Ø5/8 (Ø15.88)	53.9-57.6 (73-78)
Ø3/4 (Ø19.05)	55.3-59.0 (75-80)

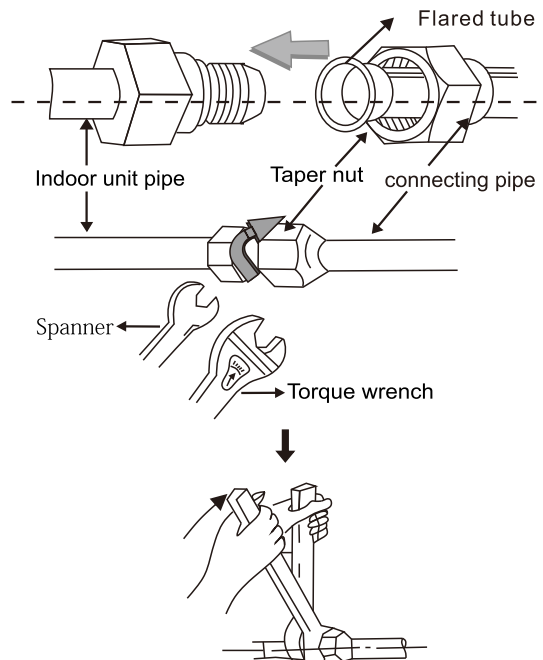

# Installation of The Outdoor Unit

## Requirement of Brazing the Pipe

- Make sure that there is no moisture inside the pipe.
- Make sure that there are no foreign materials and impurities in the pipe. Make sure that there is no leak.
- Be sure to follow the instruction when brazing the pipe.

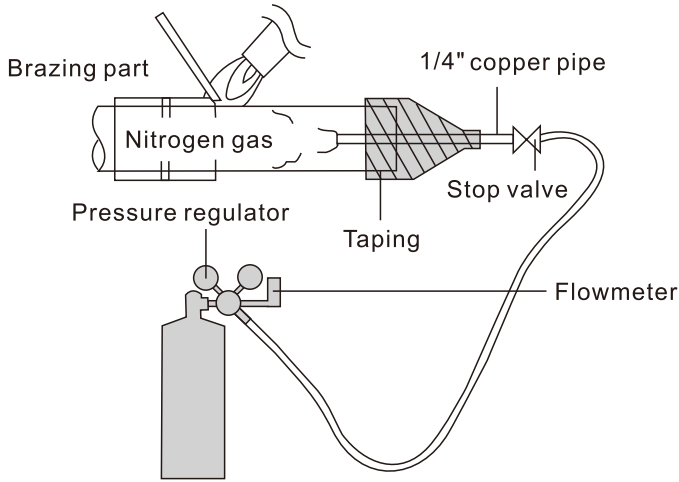

## The use of Nitrogen gas

- Use Nitrogen gas when brazing the pipes as shown in the picture. If you do not use Nitrogen gas when brazing the pipes, oxide may form inside the pipe. It can cause the damage of the compressor, valves.
- Adjust the flow rate of the Nitrogen gas with a pressure regulator to maintain 0.05m<sup>3</sup>/h or less.

### Note:

- Carefully check if there is any damage of joints before installation.
- The joints shall not be reused, unless after re-flaring the pipe.
- When the length of the connecting pipe is changed, extra amount of refrigerant need to be added, so that the operation and performance of the air conditioner will not be compromised.
- After installation, check the stop valve cover whether be fixed effectively.
- Wrap up all pipe, water discharge and connection wire from top to below.
- Cover the connection and fix them with two plastic rings.

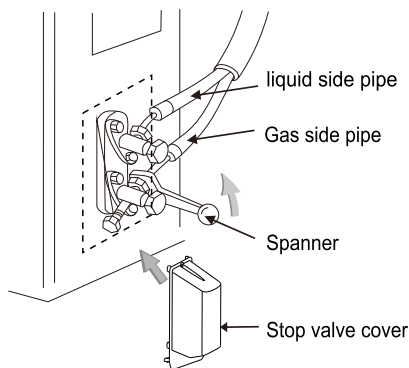

## Vacuumping

The refrigerant of R32 model must be evacuated. Before working on the air conditioner, remove the cover of the stop valve (gas and liquid valves, be sure to re-tighten it afterward to prevent the potential air leakage).

1. To prevent air leakage, make sure all flares are properly connected and torqued.
2. Connect the stop valve, charge hose, manifold valve, and vacuum pump to the unit.
3. Fully open the handle of the manifold valve and apply vacuum for at least 15 minutes and check that the compound vacuum gauge reads -0.1MPa(-76cmHg).
4. After applying vacuum, fully open the stop valve with a hex wrench.
5. Check that both indoor and outdoor connections are free of air leakage.

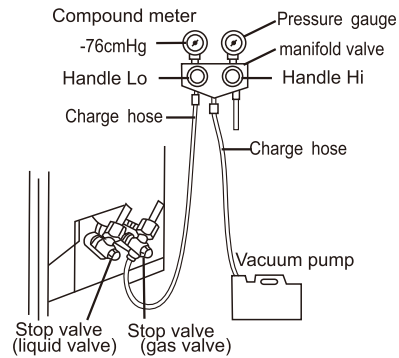

## Adjust the Refrigerant Quantity

When pipe length exceeds 24-5/8ft (7.5m), please add refrigerant according to the table below:

Refrigerant pipe	Refrigerant pipe specification		Additional fill of refrigerant (oz/ft(kg/m))
	Gas pipe (Øin.(mm))	Liquid pipe (Øin.(mm))	
Tubing between indoor unit and outdoor unit	5/8(15.88)	3/8(9.52)	0.54(0.05)
	3/4(19.05)	3/8(9.52)	

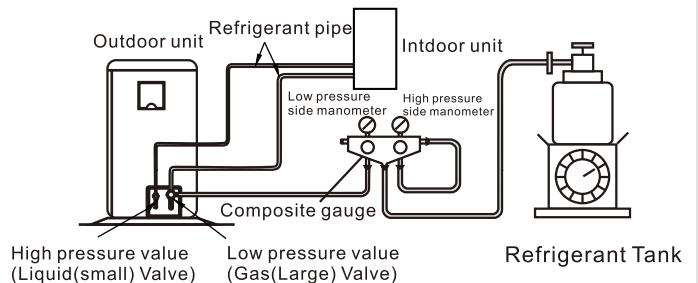

### Note:

- This table is for reference only.
- The joints shall not be reused, unless after re-flaring the pipe.
- After installation, check the stop valve cover whether be fixed effectively.
- The thickness of the pipe is 0.6-1.0, bearing pressure is 4.2 Mpa.
- If the connection pipe is too long, the cooling capacity and stability would be decreased. And the more bend quantity, the resistance in the piping system would be bigger, then the cooling and heating capacity would be decreased even lead to compressor broken. We suggest you to use the shortest connection pipe according to the pipe length parameter in this manual.
- Please add refrigerant according to liquid pipe.
- After the refrigerant filling, please fill in the perfusion amount on the fuselage label.

# Electric Wiring Work

## Electrical Safety Requirements

- Be sure to use the correct rated voltage for the air conditioner and a dedicated circuit for the power supply,
- Follow local and national codes for the correct power cable AWG.
- The operating range is 90%-110% of the local rated voltage. But insufficient power supply malfunction, electrical shock, or fire. If the voltage instability, proposed to increase the voltage regulator.
- The minimum clearance between the air conditioner and the combustibles is 4-15/16ft (1.5m) or greater.
- Use the correct wire size and type for connecting the indoor unit to the outdoor unit.
- The size of the interconnection cord, power cable, fuse, and switch needed is determined by the maximum current of the unit.
- The maximum current is indicated on the nameplate located on the side panel of the unit. Refer to this nameplate to choose the right wire size, breaker, or switch.
- All electrical works must be carried out & checked by a qualified electrician and must adhere to the IET regulations, local and national legislation and industry best practice. The system must have its own independent power supply.
- Do not attempt any electrical works yourself.
- An Earth Leakage Protector, Power Switch and Circuit Breaker or Fuse must be installed in the dedicated power supply or there is the risk of electric shock.
- The grounding must be reliable. If grounding is not correct, it may lead to electric shock.
- All power cables should be properly secured with cable ties so that external forces can not disconnect the wired from the terminals. Improper connections or insecure fastening can cause electric shocks or fire.
- Shut off the power before doing any work.
- All field supplied parts and materials, electric works must conform to local codes.
- Use copper conductors only.
- See also the "Wiring Diagram Label" located inside the unit's front cover.
- For details on hooking up the remote controller, refer to the "REMOTE CONTROLLER INSTALLATION MANUAL".
- All wiring must be performed by an authorized electrician.
- Install a wiring interrupter or ground-fault circuit interrupter for the power wiring.
- Make sure the ground resistance is no greater than 100Ω.
- To avoid short circuiting the power supply wire, be sure to use insulated terminals.
- Do not turn on the power supply (wiring interrupter or ground-fault circuit interrupter) until all other work is done.

### ⚠ CAUTION



- Do not connect the earth cable to gas or water pipes, telephone lines, lightning rods or the earth cables of other products.
- Once the indoor and outdoor unit have been switched on, do not cut off power off power supply in 1 minute, (the system automatically set) otherwise abnormal operation will be caused.
- Please connect the power cord and interconnecting cable according to the wiring diagram.
- Connect the wire firmly to the terminal block using crimps and secure in order to prevent external forces pulling on the wire causing risk of fire or electric shock.
- After the electrical connection is completed, all wires should be prevented from touching other parts such as tubing, compressor etc.

## Selection of Electrical Parts

- The definition of power cord is the power supply cable from the isolating switch attached to the dedicated power supply to the indoor unit or outdoor unit. Interconnecting cable for the indoor and outdoor unit is the power cable that connects indoor unit and outdoor unit.
- Above-mentioned definitions are the specifications of power supply, power cord and interconnecting cable of indoor unit and outdoor unit of all different types of air conditioners.
- To avoid voltage drops, when the cross sectional area of a power cable core reaches the minimum size, and the power cord is lengthened, you should choose another bigger power cable size.

The wiring cable specification that is needed in the installation: (Recommended specifications)

Model	Recommended power line (AWG)	Recommended communication cable	Switch/fuse nominal value(A)	Certification Type
ACiQ-18-HP-E-32	14	22AWG ≤1640ft. (≤500m)	20	UL
ACiQ-24-HP-E-32	12		25	
ACiQ-30-HP-E-32	12		25	
ACiQ-36-HP-E-32	12		30	
ACiQ-48-HP-E-32	8		40	
ACiQ-60-HP-E-32	8		45	

If other than uncoated (non-plated) 75°C copper wire (solid wire for 10 AWG and smaller, stranded wire for larger than 10 AWG) is used consult applicable tables of the National Electric Code (ANSI/NFPA 70).

Specifications of circuit breaker are based on a working condition where the working temperature is 40°C. If working condition changes, please adjust the specifications according to national standards.

## Wiring Connection

- Open the outdoor unit electrical access panel and connect cables according to the circuit diagram on the backside of the access panel. And check all cables are connected safely, securely and correctly. Earth wire must be connected at the right location
1. Loosen the screws and remove E-parts cover from the unit.
  2. Connect the cables respectively to the corresponding terminals of the terminal board of the outdoor unit (see the wiring diagram), and if there are signals connected to the plug, just conduct butt joint.
  3. Ground wire: Remove the grounding screw out of the electric bracket, cover the grounding wire end onto the grounding screw and screw it into the grounding hole.
  4. Fix the cable reliably with fasteners.
  5. Put the E-parts cover back in its original place and fasten it with screws.

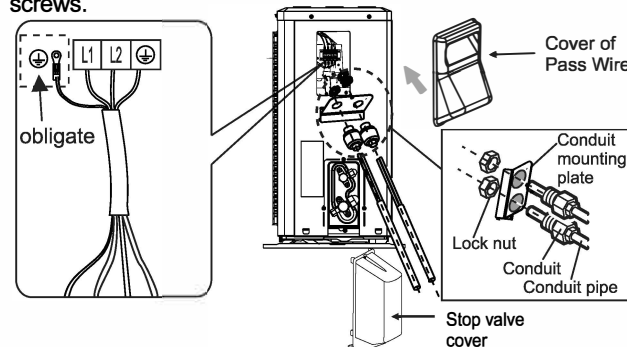

# Electric Wiring Work

## Connection Wire

### Precautions when laying power supply wiring

- Wiring of different thicknesses cannot be connected to the power supply wiring terminal block. Slack in the power supply wiring may cause abnormal heat.
- Use sleeve-insulated round crimp-style terminals for connections to the power supply wiring terminal block. When none are available, connect wires of the same diameter to both sides, as shown in the figure.

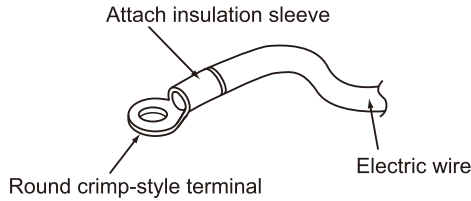

Connect wires of the same gauge to both sides.

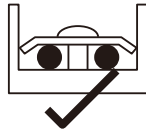

Do not connect wires of the same gauge to one side.

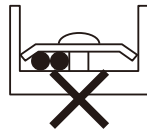

Do not connect wires of different gauges.



If the wiring gets too hot due to loose power-supply wiring, use the following precautions:

- For wiring, use the designated power supply wiring and connect firmly, then secure to prevent outside pressure being exerted on the terminal board.
- Use the correct screwdriver for tightening the terminal screws. If the blade of screwdriver is too small, the head of the screw might be damaged, and the screw will not be properly tightened.
- If the terminal screws are tightened too hard, screws might be damaged.

## 24V Control logic

### Indoor unit connector

Connector	Purpose
R	24V AC power supply
C	24V Common
G	Fan Control
Y1	Low cooling
Y2	High cooling
B	Heatingreversing Valve
W1	Stage 1 Electric Heating
W2	Stage 2 Electric Heating
DH	Dehumidification
D	Defrosting signal
L	Fault signal

### Outdoor unit connector

Connector	Purpose
C	24V Common
Y/Y2	High cooling
B	Heatingreversing Valve
D	Defrosting signal
L	Fault signal

**NOTE:** When outdoor defrosts, D of outdoor unit will send 24V signal to avoid cold winds.

**NOTE:** When refrigerant leakage in the indoor unit, L of the indoor unit will send 24V signal to shut down the Outdoor unit

## 24V Signal Chart

Mode	terminal							
	G	Y1	Y2	B	W1	W2	DH	Fan speed
OFF	0	0	0	0	0	0	0	OFF
FAN	1	0	0	*	*	*	0	High
	*	0	0	*	*	*	1	LOW
COOLING	*	1	0	0	*	*	0	Med
	*	*	1	0	*	*	0	High
Dehumidification	*	1	0	0	*	*	1	Low
	*	*	1	0	*	*	1	Low
HEATING	*	1	0	1	0	0	*	Med
	*	*	1	1	0	0	*	High
HEATING+ Electric heater kit 1	*	1	0	1	1	0	*	High
	*	*	1	1	1	0	*	High
HEATING+ Electric heater kit 2	*	1	0	1	*	1	*	High
	*	*	1	1	*	1	*	High

Note:

1: 24V signal 0: No 24V signal \*: 1 or 0.

The AHU will turn off if the 24V input cannot meet the table.

Electric heating cannot be turned on when not in the heating mode.

# Electric Wiring Work

## RS485 Communication

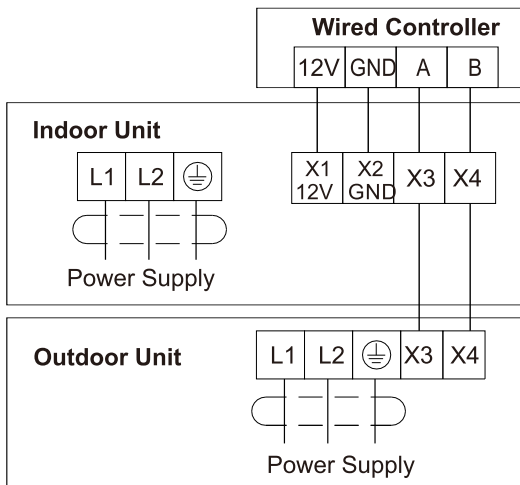

## RS485 communication with 24V thermostat

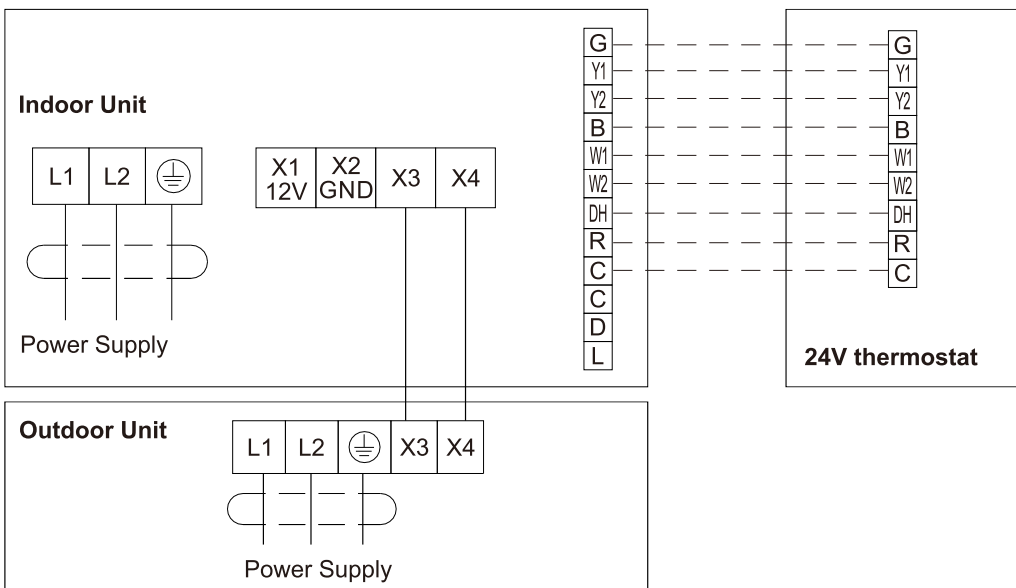

## 24V Communication

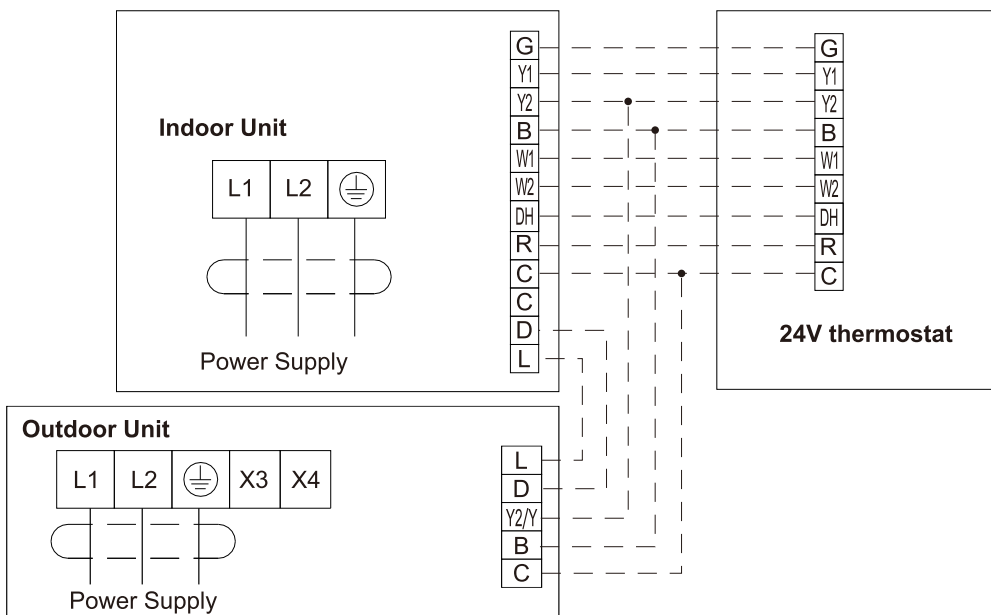

ENGLISH

# Fault Code

After indoor and outdoor units shut down due to failure, failure code will display on wired controller or remote receiving board. In case of normal protection, no failure code will display on wired controller or remote receiving board of indoor unit. Among others, wired controller doesn't automatically send warning, which requires pressing CHECK button to display corresponding failure codes. Remote receiving board directly displays failure codes. After failures are removed, display will automatically disappear.

## Outdoor Unit Malfunction

No.	Fault code	Fault description	Causes of possible failure
1	A9	Communication error between the outdoor unit and the indoor unit	Damage of the main PCB on the indoor unit
			Damage of the main PCB on the outdoor unit
			Poor wiring
2	C1	Fault with the Environmental temperature sensor on the outdoor unit	Damage of the Environmental temperature sensor on the outdoor unit
			Poor contact of the Environmental temperature sensor on the outdoor unit
			Damage of wiring of the Environmental temperature sensor on the outdoor unit
			Damage of the main PCB on the outdoor unit
3	C2	Fault with the defrosting temperature sensor on the outdoor unit	Damage of the defrosting temperature sensor on the outdoor unit
			Poor contact of the defrosting temperature sensor on the outdoor unit
			Damage of wiring of the defrosting temperature sensor on the outdoor unit
			Damage of the main PCB on the outdoor unit
4	C3	Fault with the discharge temperature sensor	Damage of the discharge temperature sensor on the outdoor unit
			Poor contact of the discharge temperature sensor on the outdoor unit
			Damage of wiring of the discharge temperature sensor on the outdoor unit
			Damage of the main PCB on the outdoor unit

5	C6	Fault with the suction temperature sensor	Damage of the suction temperature sensor on the outdoor unit
			Poor contact of the suction temperature sensor on the outdoor unit
			Damage of wiring of the suction temperature sensor on the outdoor unit
			Damage of the main PCB on the outdoor unit
6	C8	Fault with the temperature sensor in the middle of outdoor condenser	Damage of the temperature sensor on the outdoor unit
			Poor contact of the temperature sensor on the outdoor unit
			Damage of wiring of the temperature sensor on the outdoor unit
			Damage of the main PCB on the outdoor unit
7	E1	Fault of four way valve	Damage of four-way valve
			Damage to coil of four-way valve
8	E3	Protection high temperature discharge	Lack of the refrigerant
			Stop valve unopened
			Damage of the main PCB on the outdoor unit
9	E8	Fault with anti-high temperature protection of indoor unit in heating model (or outdoor unit in cooling model)	Outdoor condenser viscera
			Indoor evaporator viscera
10	E9	Drive module temperature too low protection	Inappropriate ambient temperature (too low indoor temperature and too high outdoor temperature)
			Fault with the refrigerant sensor
11	F1	Fault with the pressure sensor	Damage of the main PCB on the outdoor unit
			Poor wiring
			Fault with the pressure sensor
12	F6	Low pressure too low protection	Lack of the refrigerant
			Stop valve unopened

# Fault Code

No.	Fault code	Fault description	Causes of possible failure
13	H1	Fault with the High pressure switch	System pipeline blockage
			Damage of the pressure switch
14	H4	Fault with the low pressure switch	Lack of the refrigerant
			Stop valve unopened
			Damage of the pressure switch
15	H5	Refrigerant shortage protection	lack of refrigerant
16	3E	Compressor drive PFC software protection	Excessive running current of the unit
			Voltage drops abruptly in operation
17	3F	Compressor drive PFC hardware protection	Damage of the PFC circuit components
			Reactor damage
18	3H 5H	Fault with the Fan motor of outdoor unit	Damage of motor
19	J7	Fault with the outdoor unit EPROM	Chip damage

20	J3	Communication error between the driver PCB and main PCB of the outdoor unit	Damage of the driver PCB on the outdoor unit
			Damage of the main PCB on the outdoor unit
			Poor wiring
21	31	Fault with the inverter module protection	Fault with the inverter module protection
22	32	Compressor drive hardware protection	Damage of the EE chip of driver board
23	35	Fault with the over-electric current protection	Excessive running current of the unit
			Voltage drops abruptly in operation
24	36	Fault with the over-voltage or low voltage protection	Excessive input voltage
			Lower input voltage
25	37	Fault with the modular temperature sensor on the outdoor unit	Sensor damage of compressor IPM module
26	39	Protection of compressor driving module for excessive temperature	Poor contact between compressor IPM module and radiator

## Testing and Inspection

### Check after Installation

#### ●Electrical Safety Check

1. If the supply voltage is within tolerance.
2. If the indoor and outdoor units are properly wired.
3. If the grounding wire of the air conditioner is securely grounded.

#### ●Installation Safety Check

- 1.If the unit is mounted properly and securely.
- 2.If the water drains smoothly from indoor unit to outdoor drain.
- 3.If the wiring and piping are correctly installed and free of leaks.
- 4.Check that no foreign matter or tools are left inside the unit.
- 5.Check the refrigerant pipeline and connections are properly insulated.

#### ●Leak test of the refrigerant

Depending on the installation method, the following methods may be used to check for suspect leak, on areas such as the connections of the outdoor unit and the cores of the cut-off valves and t-valves:

- 1.Bubble method: Apply of spray a uniform layer of soap water over the suspected leak spot and observe carefully for bubble.
- 2.Instrument method: Checking for leak by pointing the probe of the leak detector according to the instruction to the suspect points of leak.

#### **Note:**

**Make sure that the ventilation is good before checking.**

### Test Operation

#### ●Test Operation preparation:

1. Verify that all piping and wiring is properly connected.
2. Confirm that the valve at the gas side and the liquid-side are fully open.
3. Verify that power is turned on to the unit.
4. Install batteries in the remote control.

#### **Note:**

**Make sure that the ventilation is good before testing.**

#### ●Test Operationmethod:

- 1.Turn on the power and push the ON/OFF switch button of the remote controller to start the air conditioner.
- 2.Select COOL or HEAT, adjust the SWING and other operation modes with the remote controller to verify proper operation.

# Maintenance Notice

## **Attention :**

**For maintenance or scrap, please contact a authorized contractor.**

**Maintenance by unqualified person may cause injury or damage to the unit.**

**Charge air conditioner with R32 refrigerant only, and maintain the air conditioner in a strict accordance with the manufacturer's requirements.**

## **Qualification of Workers**

1. Special training is required to work on equipment with A2L refrigerants. Only rely on qualified contractors to install, service, and repair this system.

2. The maintenance and repair of the air conditioner must be conducted according to the method recommended by the manufacturer.

If other professionals are needed to help maintain and repair the equipment, it should be conducted under the supervision of individuals who have the qualification to repair AC equipped with flammable refrigerants.

## **Inspection of the Site**

Safety inspection must be conducted before maintaining equipment with R32 refrigerant to make sure the risk of fire is minimized.

Check whether the space is well ventilated and whether anti-static or fire prevention equipment is required.

While maintaining the refrigeration system, observe the following precautions before operating the system.

## **Operating Procedures**

### **1. General work area:**

All maintenance staff and others working in the local area shall be instructed on the nature of work being carried out. Work in confined spaces shall be avoided.

### **2. Checking for presence of refrigerant:**

The area shall be checked with an appropriate refrigerant detector prior to and during work, to ensure the technician is aware of potentially toxic or flammable atmospheres. Ensure that the leak detection equipment being used is suitable for use with all applicable refrigerants, i.e. non-sparking, adequately sealed or intrinsically safe.

### **3. Presence of fire extinguisher:**

If any hot work is to be conducted on the refrigerating equipment or any associated parts, appropriate fire extinguishing equipment shall be available to hand. Have a dry powder or CO2 fire extinguisher adjacent to the charging area.

### **4. No ignition sources:**

No person carrying out work in relation to a REFRIGERATING SYSTEM which involves exposing any pipe work shall use any sources of ignition in such a manner that it may lead to the risk of fire or explosion. All possible ignition sources, including cigarette smoking, should be kept sufficiently far away from the site of installation, repairing, removing and disposal, during which refrigerant can possibly be released to the surrounding space. Prior to work taking place, the area around the equipment is to be surveyed to make sure that there are no flammable hazards or ignition risks. "No Smoking" signs shall be displayed.

### **5. Ventilated Area:**

Ensure that the area is in the open or that it is adequately ventilated before breaking into the system or conducting any hot work. A degree of ventilation shall continue during the period that the work is carried out. The ventilation should safely disperse any released refrigerant and preferably expel it externally into the atmosphere.

### **6. Checks to the refrigeration equipment:**

Where electrical components are being changed, they shall be fit for the purpose and to the correct specification. At all times the manufacturer's maintenance and service guidelines shall be followed. If in doubt, consult the manufacturer's technical department for assistance.

The following checks shall be applied to installations using FLAMMABLE REFRIGERANTS:

- The actual REFRIGERANT CHARGE is in accordance with the room size within which the refrigerant containing parts are installed;
- The ventilation machinery and outlets are operating adequately and are not obstructed;
- If an indirect refrigerating circuit is being used, the secondary circuit shall be checked for the presence of refrigerant;
- Marking to the equipment continues to be visible and legible. Markings and signs that are illegible shall be corrected;
- Refrigerating pipe or components are installed in a position where they are unlikely to be exposed to any substance which may corrode refrigerant containing components, unless the components are constructed of materials which are inherently resistant to being corroded or are suitably protected against being so corroded.

### **7. Checks to electrical devices:**

Repair and maintenance to electrical components shall include initial safety checks and component inspection procedures. If a fault exists that could compromise safety, then no electrical supply shall be connected to the circuit until it is satisfactorily dealt with. If the fault cannot be corrected immediately but it is necessary to continue operation, an adequate temporary solution shall be used. This shall be reported to the owner of the equipment so all parties are advised.

Initial safety checks shall include:

- That capacitors are discharged: this shall be done in a safe manner to avoid possibility of sparking;
- That no live electrical components and wiring are exposed while charging, recovering or purging the system;
- That there is continuity of earth bonding.

## **Repairs to Sealed Components**

● During repairs to sealed components, all electrical supplies shall be disconnected from the equipment being worked upon prior to any removal of sealed covers, etc. If it is absolutely necessary to have an electrical supply to equipment during servicing, then a permanently operating form of leak detection shall be located at the most critical point to warn of a potentially hazardous situation.

- Sealed electrical components shall be replaced.

# Maintenance Notice

## Repair to Intrinsically Safe Components

● Do not apply any permanent inductive or capacitance loads to the circuit without ensuring that this will not exceed the permissible voltage and current permitted for the equipment in use.

- Intrinsically safe components must be replaced.
- Replace components only with parts specified by the manufacturer. Other parts may result in the ignition of refrigerant in the atmosphere from a leak.

**NOTE:** The use of silicon sealant can inhibit the effectiveness of some types of leak detection equipment. Intrinsically safe components do not have to be isolated prior to working on them.

## Cabling

Check that cabling will not be subject to wear, corrosion, excessive pressure, vibration, sharp edges or any other adverse environmental effects. The check shall also take into account the effects of aging or continual vibration from sources such as compressors or fans.

## Detection of Flammable Refrigerants

● Under no circumstances shall potential sources of ignition be used in the searching for or detection of refrigerant leaks. A halide torch (or any other detector using a naked flame) shall not be used.

● The following leak detection methods are deemed acceptable for all refrigerant systems.

● Electronic leak detectors may be used to detect refrigerant leaks but, in the case of FLAMMABLE REFRIGERANTS, the sensitivity may not be adequate, or may need re-calibration. (Detection equipment shall be calibrated in a refrigerant-free area.) Ensure that the detector is not a potential source of ignition and is suitable for the refrigerant used. Leak detection equipment shall be set at a percentage of the LFL of the refrigerant and shall be calibrated to the refrigerant employed, and the appropriate percentage of gas (25 % maximum) is confirmed.

● Leak detection fluids are also suitable for use with most refrigerants but the use of detergents containing chlorine shall be avoided as the chlorine may react with the refrigerant and corrode the copper pipe-work.

**NOTE:**

Examples of leak detection fluids are

- bubble method,
- fluorescent method agents.

- If a leak is suspected, all naked flames shall be removed/extinguished.
- If a leakage of refrigerant is found which requires brazing, all of the refrigerant shall be recovered from the system, or isolated (by means of shut off valves) in a part of the system remote from the leak.

## Removal and Evacuation

1. When breaking into the refrigerant circuit to make repairs – or for any other purpose – conventional procedures shall be used. However, for flammable refrigerants it is important that best practice be followed, since flammability is a consideration. The following procedure shall be adhered to:

- safely remove refrigerant following local and national regulations;
  - reevacuate;
  - purge the circuit with inert gas (optional for A2L);
  - evacuate (optional for A2L);
  - purge with inert gas (optional for A2L);
  - continuously flush or purge with inert gas when using flame to open circuit, and open the circuit.
2. The refrigerant charge shall be recovered into the correct recovery cylinders if venting is not allowed by local and national codes. For appliances containing flammable refrigerants, the system shall be purged with oxygen-free nitrogen to render the appliance safe for flammable refrigerants. This process might need to be repeated several times. Compressed air or oxygen shall not be used for purging refrigerant systems.
3. For appliances containing flammable refrigerants, refrigerants purging shall be achieved by breaking the vacuum in the system with oxygen-free nitrogen and continuing to fill until the working pressure is achieved, then venting to atmosphere, and finally pulling down to a vacuum (optional for A2L). This process shall be repeated until no refrigerant is within the system (optional for A2L). When the final oxygen-free nitrogen charge is used, the system shall be vented down to atmospheric pressure to enable work to take place.
4. The outlet for the vacuum pump shall not be close to any potential ignition sources, and ventilation shall be available.

## Charging Procedures

1. In addition to conventional charging procedures, the following requirements shall be followed.
- Ensure that contamination of different refrigerants does not occur when using charging equipment.
- Hoses or lines shall be as short as possible to minimise the amount of refrigerant contained in them.
- Cylinders shall be kept in an appropriate position according to the instructions.
  - Ensure that the REFRIGERATING SYSTEM is earthed prior to charging the system with refrigerant.
  - Label the system when charging is complete (if not already).
  - Extreme care shall be taken not to overfill the REFRIGERATING SYSTEM.
2. Prior to recharging the system, it shall be pressure-tested with the appropriate purging gas. The system shall be leak-tested on completion of charging but prior to commissioning. A follow up leak test shall be carried out prior to leaving the site.

## Decommissioning

Before carrying out this procedure, it is essential that the technician is completely familiar with the equipment and all its detail. It is recommended good practice that all refrigerants are recovered safely. Prior to the task being carried out, an oil and refrigerant sample shall be taken in case analysis is required prior to re-use of recovered refrigerant. It is essential that electrical power is available before the task is commenced.

- a) Become familiar with the equipment and its operation.
- b) Isolate system electrically.

# Maintenance Notice

## Decommissioning

- c) Before attempting the procedure, ensure that:
- mechanical handling equipment is available, if required, for handling refrigerant cylinders;
  - all personal protective equipment is available and being used correctly;
  - the recovery process is supervised at all times by a competent person;
  - recovery equipment and cylinders conform to the appropriate standards.
- d) Pump down refrigerant system, if possible.
- e) If a vacuum is not possible, make a manifold so that refrigerant can be removed from various parts of the system.
- f) Make sure that cylinder is situated on the scales before recovery takes place.
- g) Start the recovery machine and operate in accordance with instructions.
- h) Do not overfill cylinders (no more than 80 % volume liquid charge).
- i) Do not exceed the maximum working pressure of the cylinder, even temporarily.
- j) When the cylinders have been filled correctly and the process completed, make sure that the cylinders and the equipment are removed from site promptly and all isolation valves on the equipment are closed off.
- k) Recovered refrigerant shall not be charged into another REFRIGERATING SYSTEM unless it has been cleaned and checked.

## Labelling

Equipment shall be labelled stating that it has been de-commissioned and emptied of refrigerant. The label shall be dated and signed. For appliances containing **FLAMMABLE REFRIGERANTS**, ensure that there are labels on the equipment stating the equipment contains **FLAMMABLE REFRIGERANT**.

## Recovery

1. When removing refrigerant from a system, either for servicing or decommissioning, it is recommended good practice that all refrigerants are removed safely.
2. When transferring refrigerant into cylinders, ensure that only appropriate refrigerant recovery cylinders are employed. Ensure that the correct number of cylinders for holding the total system charge is available. All cylinders to be used are designated for the recovered refrigerant and labelled for that refrigerant (i.e. special cylinders for the recovery of refrigerant). Cylinders shall be complete with pressure-relief valve and associated shut-off valves in good working order. Empty recovery cylinders are evacuated and, if possible, cooled before recovery occurs.
3. The recovery equipment shall be in good working order with a set of instructions concerning the equipment that is at hand and shall be suitable for the recovery of the flammable refrigerant. If in doubt, the manufacturer should be consulted. In addition, a set of calibrated weighing scales shall be available and in good working order. Hoses shall be complete with leak-free disconnect couplings and in good condition.
4. The recovered refrigerant shall be processed according to local legislation in the correct recovery cylinder, and the relevant waste transfer note arranged. Do not mix refrigerants in recovery units and especially not in cylinders.
5. If compressors or compressor oils are to be removed, ensure that they have been evacuated to an acceptable level to make certain that flammable refrigerant does not remain within the lubricant. The compressor body shall not be heated by an open flame or other ignition sources to accelerate this process. When oil is drained from a system, it shall be carried out safely.

# AACIQ

The design and specifications are subject to change without prior notice for product improvement. Consult with the sales agency or manufacturer for details. Any updates to the manual will be uploaded to the service website, please check for the latest version.

## DE-COMMISSIONING, DISMANTLING & DISPOSAL

This product contains refrigerant under pressure, rotating parts, and electrical connections which may be a danger & cause injury. All work must only be carried out by competent persons using suitable protective clothing and safety precautions.



Read the Manual



Risk of Electric Shock

**RoHS**



Unit is Remotely controlled  
& may start without warning



1. Isolate all sources of electrical supply to the unit including any control system supplies switched by the unit. Ensure that all points of electrical and gas isolation are secured in the OFF position. The supply cables and gas pipe work may then be disconnected and removed. For points of connection refer to unit installation instructions.
2. Remove all refrigerant from each system of the unit into a suitable container using a refrigerant reclaim or recovery unit. This refrigerant may then be reused, if appropriate, or returned to the manufacturer for disposal. Under no circumstances should refrigerant be vented to atmosphere. Where appropriate, drain the refrigerant oil from each system into a suitable container and dispose of according to local laws and regulations governing disposal of oily wastes.
3. Packaged units can generally be removed in one piece after disconnection as above. Any fixing down bolts should be removed and then unit lifted from position using the points provided and equipment of adequate lifting capacity. Reference **MUST** be made to the unit installation instructions for unit weight and correct methods of lifting. Note that any residual or spilt refrigerant oil should be mopped up and disposed of as described above.
4. After removal from position the unit parts may be disposed of according to local laws and regulations.
5. Meaning of crossed Out wheeled dustbin: Do not dispose of electrical appliances as unsorted municipal waste, use separate collection facilities. Contact your local government for information regarding the collection systems available. If electrical appliances are disposed of in landfills or dumps, hazardous substances can leak into the groundwater and get into the food chain, damaging your health and well being. When replacing old appliances with new ones, the retailer is legally obligated to take back your old appliance for disposals at least free of charge.